

 **WARNING**

The engine exhaust from this product contains chemicals known to cause cancer, birth defects or other reproductive harm.

**PROPOSITION 65
WARNING**

Snowmobile engines discharge fuel and exhaust, which contain chemicals known to the State of California to cause cancer and birth defects or other reproductive harm, onto the snow on which they operate. Keep this engine properly tuned and avoid unnecessary idling and spillage during fueling.

⚠ WARNING

- **Adult Vehicle Only:** This vehicle is designed for adult use only. The vehicle size, speed capabilities and control requirement prohibit operation by children.
 - **Operating With A Passenger:** (On approved models only) Operating a vehicle with a passenger reduces your ability to control the vehicle due to the added weight and change in weight distribution. Generally, reduce vehicle speeds and provide added space for maneuvering, since steering control may be reduced.
 - **Excessive speeds:** This vehicle is capable of high speeds. Exercise extreme caution when operating in unfamiliar terrain. Buried objects or uneven terrain can cause loss of control.
 - **Body Protection:** Always wear an approved helmet, eye protection and adequate clothing while operating this vehicle.
 - **Alcohol Or Drugs:** Never consume alcohol or drugs before or while operating this vehicle.
 - **Night Riding and Limited Visibility:** Limited visibility or excessive speeds may cause over-driving of headlights resulting in insufficient time to react to terrain changes or avoidance of unexpected obstacles.
 - **Auxiliary Shut Off Switch:** This switch is the primary means of stopping this vehicle in case of an emergency and is located on the top of the throttle control assembly. Depress the switch for proper function with the engine idling.
 - **Safety Throttle System:** This system is a supplementary safety device which stops the engine automatically in the event of a throttle system malfunction. See the Owner's Manual for procedure to ensure proper system operation.
 - **Vehicle Control:** The Steering and braking ability are greatly reduced when operating on hardpacked snow, ice or when crossing roads. Reduced speed and extra care are required to maintain vehicle control.
 - **Ski Skag Inspection:** Inspect ski skags for wear every 500 miles or more often when operating on abrasive surface conditions. Replace ski skags when worn to 1/2 of original diameter.
 - **Carbide Skags and Studs:** These items enhance vehicle control on ice or hardpacked surfaces. Care must be taken to maintain a proper balance of ski carbides to track studs to maintain proper vehicle control. (See the Owner's Manual for proper use of traction accessories.)
 - **Cargo Rack:** If this vehicle is equipped with a cargo rack, do not sit in or on the cargo rack. The combined cargo load and tongue weight on the hitch should not exceed 75 lbs . (34 kgs.) Cargo load affects machine steering and braking response.
 - **Rotating Track:** Stay clear of the rotating track assembly. Entanglement may result.
 - **Unfamiliar Rider:** Never permit a guest to operate this vehicle unless the guest has read the Owner's Manual and warnings.
 - **Adjustment and Service:** If you are not familiar with safe adjustment and service procedures, bring your vehicle to a qualified dealer for servicing or adjustment.
 - **Read and understand warnings and the Owner's Manual before operation.** Severe injury or death can result from not heeding the warnings or understanding the Owner's Manual.
- OIL INJECTION SYSTEM. UNMIXED FUEL ONLY. CHECK OIL LEVEL WHEN REFUELING.



POLARIS®

2000 Universal Snow

Owner's Safety

and Maintenance Manual



Part No. 9915247 Rev 02

PRINTED IN THE U.S.A.

FOREWORD

Thank you for purchasing a Polaris snowmobile. We believe it is the standard of excellence for all snowmobiles manufactured in the world today. Many years of experience in engineering, design, and development have gone into making your Polaris snowmobile the finest machine we have ever produced.

All machines, no matter how well engineered, require a certain amount of maintenance. Before using your snowmobile, take a few minutes to read through this manual and familiarize yourself with maintenance and operation procedures. It may be the most important time spent in knowing how to keep your machine running perfectly every day.

If the registration form included with your snowmobile has not been completed by you and your dealer, be certain that it is; and make sure that it is forwarded to us. This completed form is necessary to insure warranty coverage.

This manual also contains important pages devoted to safety and environment. Whether you are a long-time snowmobiler or a newcomer to this exciting winter sport, we urge you to seriously read this information.

Remember, your snowmobile is capable of traveling at high speeds. This performance has been engineered into your Polaris to allow you the ultimate snowmobiling experience. Operators must be aware of risks involved when traveling at high speeds, on iced or hard packed surfaces, at night or in unfamiliar terrain. In addition, young or novice riders who do not have the ability or experience to physically control the machine in difficult situations should be instructed to reduce their speed until they become skilled riders.

On machines designated for two passengers it is most important that the operator and rider communicate well and practice cornering techniques, rough terrain riding, etc., so that each is contributing to a safe, enjoyable ride. Keep the running board non-skid pads free of ice and snow and in good condition for increased safety and passenger comfort. The safe and courteous operation of your snowmobile - with respect for the environment - will insure you the continued enjoyment of the sport of snowmobiling.

If you should experience any problems with your snowmobile, please return it to your dealer. He has received training which will enable him to perform any required repairs. Should any additional assistance be required, your dealer will work with our technical services department to resolve any problems.

All of us at Polaris would like to extend to you our best wishes for plenty of fun-filled, safe snowmobiling pleasure with your new Polaris.

All information in this manual is based upon the latest product data and specifications available at the time of printing. Polaris Industries Inc. reserves the right to make product changes and improvements which may affect illustrations or explanations.

No part of this manual shall be reproduced or used without the written permission of Polaris Industries Inc.

Illustrations included in this manual are general representations of parts having a similar function. Your model may differ.



The Polaris Preferred Registered Owners (PRO) Family Your Owners Program

As the owner of a new Polaris vehicle, you are entitled to a FREE two- year membership in the Polaris PRO Family--the Preferred Registered Owners Family. It's an owners program for Polaris owners like you, people who have chosen the finest recreational vehicle available, people who share an interest in Polaris and its products.

Once your new vehicle's warranty is registered, you will receive a PRO Family membership packet that will include:

- ✦ A letter of welcome to the PRO Family
- ✦ A PRO Family card with your name and membership number
- ✦ A colorful sticker of the PRO logo
- ✦ A PRO merchandise brochure and order form.

As a PRO Family member, you're entitled to opportunities such as:

- ✦ A free subscription to *PRO Spirit*, the official magazine of the PRO Family
- ✦ The chance to buy insurance for you Polaris vehicle. The toll-free insurance telephone number is: 1-800-473-0111
- ✦ The chance to arrange travel through the Polaris Travel Center. The toll-free travel telephone number is: 1-800-267-1915
- ✦ The chance to apply to serve on PRO Consumer Councils that provide input into the Polaris vehicles of the future
- ✦ The chance to serve as a PRO Field Evaluator and provide feedback on your new vehicle
- ✦ The chance to take part in national PRO snowmobile, ATV or personal watercraft rides
- ✦ The chance to purchase exclusive PRO Family merchandise
- ✦ And more!

To order PRO merchandise, you'll complete the order form you receive with your membership packet, take the form to your Polaris dealer and pay for the merchandise. The merchandise will be shipped directly to your home from the PRO merchandise fulfillment center.

Watch for your PRO membership packet and the next issue of *PRO Spirit* magazine. This quarterly magazine will keep you informed about Polaris news and events, and special PRO merchandise, travel, and ride opportunities.

Enjoy your new Polaris vehicle and welcome to the family--The Polaris PRO Family.

TABLE OF CONTENTS

UNDERSTANDING WARNINGS	1
SAFETY WARNING AND OPERATION DECALS	2-9
OPERATION WARNINGS	10-24
PRESERVATION OF THE ENVIRONMENT	25
IDENTIFICATION AND SPECIFICATIONS	26-30
OPERATION	31-44
BATTERY	45-47
MAINTENANCE	48-105
SUSPENSION	106-134
TROUBLESHOOTING	135-141
ACCESSORIES	142
SERVICE AND WARRANTY	143
WARRANTY	144-147
INDEX	148-149

UNDERSTANDING WARNINGS

SAFETY ALERT

The following precautionary signal words are used throughout this manual to convey the following messages:



This is the safety alert symbol. When you see this symbol on your machine or in this manual, be alert to the potential for personal injury. Your safety is involved!



WARNING

Indicates a potential hazard which could result in serious injury or death.



CAUTION

Indicates a potential hazard which may result in minor personal injury or damage to the snowmobile.

NOTE

The word “NOTE:” in this manual will alert you to key information or instructions.

SAFETY WARNING AND OPERATION DECALS

WARNING

Driving a snowmobile requires your full attention. **Do not** drink alcohol or use drugs or medications before or while driving as they will reduce your alertness and slow your reaction time. In most states and provinces it is prohibited by law to drive while intoxicated or under the influence of drugs.

Be smart, be safe, don't drink and drive!

SAFETY WARNING AND OPERATION DECALS



Polaris Indys are high performance snowmobiles capable of traveling at very high speeds. Because of this, extra caution must be observed to ensure operator safety. Particular caution must be taken to make sure that the snowmobile is in excellent operating condition at all times. As with any performance snowmobile, we strongly recommend the operator check major and vital safety components each time before riding.

All Polaris snowmobiles have been designed and tested to provide safe operation when used as directed. Failure of critical machine components may result from operation with any modification; especially those which increase speed or power. The machines may become aerodynamically unstable at speeds above those for which they are designed. There is also a significant possibility of loss of control at higher speeds.

Due to our concern for the safety of our customers and the general public, Polaris hereby strongly recommends and requests that consumers do not install on a Polaris snowmobile any equipment which is intended to increase the speed or power of the machine, or make any other modifications to the machines for these purposes. Any modifications to the original equipment or the snowmobiles substantially increase the risk of bodily injury. Be aware that these modifications may create a substantial safety hazard.

Polaris hereby informs you that the warranty on a snowmobile is terminated on the entire machine if any such equipment has been added to the machine or any modifications have been made to the machine which increase its speed or power.

We also advise you to strictly follow the recommended maintenance program outlined on pages 48-100. This preventative maintenance program is designed to ensure that all critical components on the snowmobile are thoroughly inspected by your dealer at various mileage intervals.

SAFETY WARNING AND OPERATION DECALS

Your snowmobile is not a toy. It is a well-engineered and well constructed recreational vehicle. The following information is provided to aid you in its safe operation.

NOTE: Warning decals have been placed on the vehicle for your protection. Read and follow the instructions on each decal carefully. In the event any decal becomes illegible or comes off, contact your Polaris dealer for a replacement. Any safety decal needing replacement will be provided by Polaris at no charge. The part number is printed on the decal.

CAUTION: Although your Polaris has been designed to provide you with a safe, reliable snowmobile, much of its safety depends on the operator. Improper use of this snowmobile or failure to maintain it in good operating condition can result in injury. To reduce this possibility, read the following important safety information.

SAFETY WARNING AND OPERATION DECALS

(Text Below)

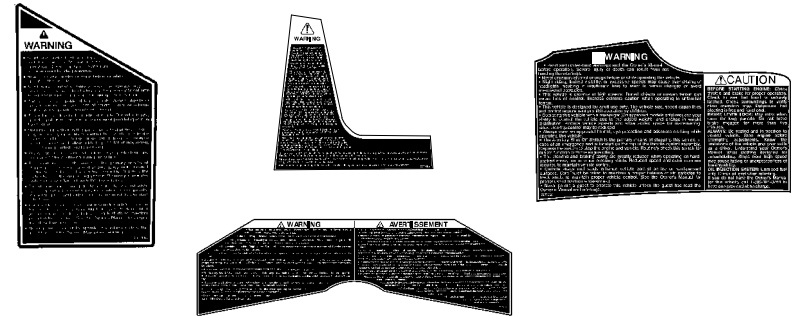

⚠ WARNING

- Read and understand warnings and the Owner's Manual before operation. Severe injury or death can result from not heeding the warnings.
- Never consume alcohol or drugs before or while operating this vehicle.
- Night riding, limited visibility, or excessive speeds may cause over-driving of headlights resulting in insufficient time to react to terrain changes or avoid unexpected obstacles.
- This vehicle is capable of high speeds. Buried objects or uneven terrain can cause loss of control. Exercise extreme caution when operating in unfamiliar terrain.
- This vehicle is designed for adult use only. The vehicle size, speed capabilities and control requirement prohibit operation by children.
- Operating this vehicle with a passenger (On approved models only) reduces your ability to control the vehicle due to the added weight and change in weight distribution. Reduce vehicle speeds and allow added space for maneuvering, since steering control may be reduced.
- Always wear an approved helmet, eye protection and adequate clothing while operating this vehicle.
- The Auxiliary Shut Off Switch is the primary means of stopping this vehicle in case of an emergency and is located on the top of the throttle control assembly. Depress the switch to stop the engine and vehicle. Routinely check this switch for proper function with the engine idling.
- The steering and braking ability are greatly reduced when operating on hard packed snow, ice or when crossing roads. Reduced speed and extra care are required to maintain vehicle control.
- Carbide skags and studs enhance vehicle control on ice or hard-packed surfaces. Care must be taken to maintain a proper balance of ski carbides to track studs to maintain proper vehicle control. (See the Owner's Manual for proper use of traction accessories.
- Never permit a guest to operate this vehicle unless the guest has read the Owner's Manual and warnings.

SAFETY WARNING AND OPERATION DECALS

(Text Below)

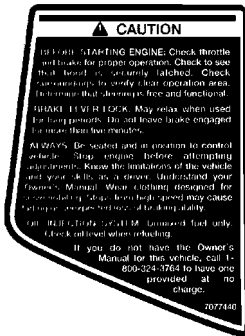
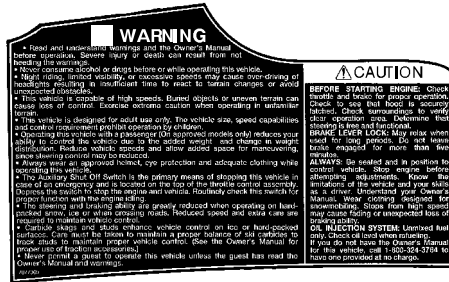
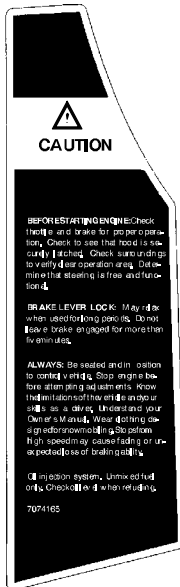

BEFORE STARTING ENGINE: Check throttle and brake for proper operation. Check to see that hood is securely latched. Check surroundings to verify clear operation area. Determine that steering is free and functional.

BRAKE LEVER LOCK: May relax when used for long periods. Do not leave brake engaged for more than five minutes.

ALWAYS: Be seated and in position to control vehicle. Stop engine before attempting adjustments. Know the limitations of the vehicle and your skills as a driver. Understand your Owner's Manual. Wear clothing designed for snowmobiling. Stops from high speed may cause fading or unexpected loss of braking ability.

Oil injection system: Unmixed fuel only. Check oil level when refueling.

If you do not have the Owner's Manual for this vehicle, call 1-800-324-3764 to have one provided at no charge.

SAFETY WARNING AND OPERATION DECALS

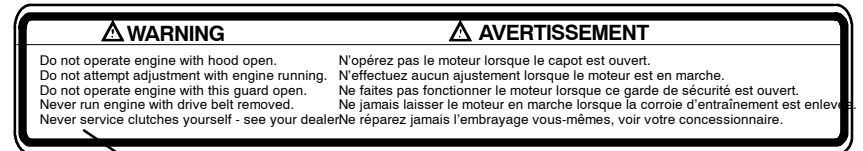

Do not operate engine with hood open.
 Do not attempt adjustment with engine running.
 Do not operate engine with this guard open.
 Never run engine with drive belt removed.
 Never service clutches yourself - see your dealer.

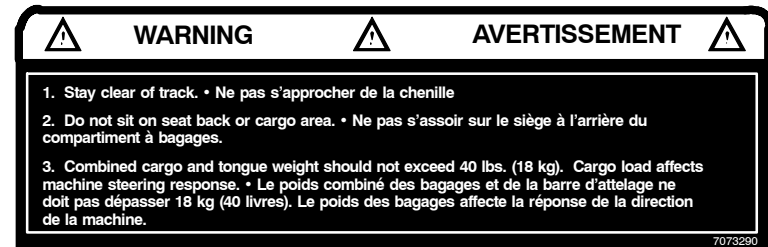

1. Stay clear of track.
2. Do not sit on seat back or cargo area.
3. Combined cargo and tongue weight should not exceed 40 lbs. (18 kg). Cargo load affects machine steering response.

SAFETY WARNING AND OPERATION DECALS

Models Equipped With Reverse Only
(Text Below)

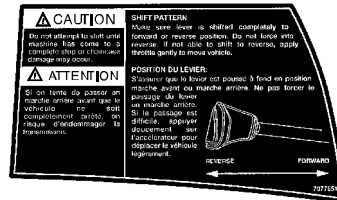
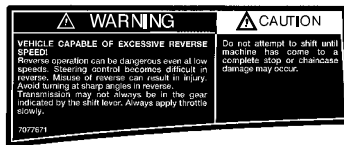
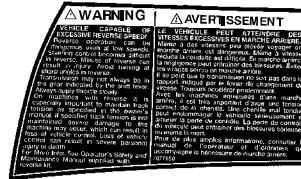

NOTE: Illustration of shift pattern may vary. Your model may differ.

VEHICLE CAPABLE OF EXCESSIVE REVERSE SPEED!

Reverse operation can be dangerous even at low speeds. Steering control becomes difficult in reverse. Misuse of reverse can result in injury. Avoid turning at sharp angles in reverse.

Transmission may not always be in the gear indicated by the shift lever. Always apply throttle slowly.

On machines with reverse it is especially important to maintain track tension as specified in the owner's manual. If specified track tension is not maintained severe damage to the machine may occur, which can result in loss of vehicle control. Loss of vehicle control can result in severe personal injury or death.

For More Info: See Operator's Safety and Maintenance Manual supplied with reverse kit.

SHIFT PATTERN

Make sure lever is shifted completely to forward or reverse position. Do not force into reverse. If not able to shift to reverse, apply throttle gently to move vehicle. **CAUTION:** Do not attempt to shift until machine has come to a complete stop or chaincase damage may occur.

SAFETY WARNING AND OPERATION DECALS

Some Liquid Cooled Models



Release pressure before removing cap. Cooling fluid must be up to the base of the pressure cap in hot or cold conditions.

Refer to the Owner's Manual for fluid level in overflow bottle.

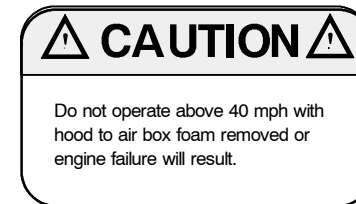

OPERATION WARNINGS

Before Starting The Engine



Read and Understand Your Owner's Manual

Read the Owner's Manual completely now, and re-read it occasionally. We have attempted to provide you with as much information as possible to alert you to the safety requirements of snowmobiling.



Check Throttle and Brake for Proper Operation

The throttle and brake are the primary controls of your snowmobile. If either should malfunction, a serious loss of control could result.

When checking the throttle, make sure the control lever will compress evenly and smoothly. When the lever is released, it should immediately return to the idle position without binding or hesitation. If the throttle does not function smoothly, do not attempt to start the engine. Have the throttle serviced before starting the engine.

The need for a properly functioning brake is vital. This snowmobile is equipped with the highest quality brake system available. The brake must be checked for correct operation before starting the engine. See page 13 for details.



Check for Proper Operation of Steering System

Check for proper operation of the steering system by manually turning the skis completely to the right and to the left. If difficulty is encountered, check for ice and snow buildup which may be obstructing the steering linkage. Make certain all greasable components are properly lubricated.



Single Rider Snowmobiles

Some Polaris snowmobile models are designed for a single occupant only. A decal on the console of these models indicates single occupant operation.



OR



OPERATION WARNINGS

Driving 2-Up

When operating a 2-Up machine with a passenger, the driver should be aware that more space will be required to make turns, and a longer distance will be necessary for stopping. Lower speeds should be observed whenever riding 2-Up.

CAUTION: Always make certain the passenger remains seated behind the driver, facing forward, with both feet placed firmly on the running boards. Reduce operating speed and be particularly careful to avoid “jumping” your snowmobile.

Some Polaris snowmobile models are designed for two occupants. A decal on the hood of these models indicates that the vehicle is designed for one operator and one passenger only. Machines designated as double occupant should never be operated with more than two people on board. When traveling with a passenger aboard, it is the driver’s responsibility to operate the machine in a safe manner. Remember that control becomes more difficult with two people on board. Reduce speeds to retain control!

WARNING

Use of a backrest can hinder operator weight shifting. This may affect control of this rider-active vehicle in certain extreme driving situations.

WARNING/AVERTISSEMENT

This vehicle is designed for operator and “ONE” passenger only.

Ce véhicule est conçu pour ne transporter que le conducteur et “UN SEUL” passager.

Track Inspection

Driving at wide-open throttle for extended periods of time in marginal lubrication could severely damage track rods, break track edges, and cause other track damage. Examples of marginal lubrication would include lakes without snow cover, icy trails and no-snow conditions.

Always inspect for damage before using the vehicle. Use of traction products such as studs, ice growlers, paddles, etc. will increase the possibility of track damage and/or failure. Operating the snowmobile with a damaged track will increase the possibility of track damage and/or failure, which could cause loss of control resulting in severe injury or death.

NOTE: Track damage or failure caused by operation on ice or poor lubrication conditions will void the track warranty.

Do Not Operate Engine With Intake Silencer or Filter Removed

When operating engine with intake silencer or filter removed, damage to the engine may occur.

or

WARNING/AVERTISSEMENT

This vehicle is designed for operator and “ONE” passenger only.
Ce véhicule est conçu pour ne transporter que le conducteur et “UN SEUL” passager.

7077629

OPERATION WARNINGS



Stay Clear of Track

During warm-up and operation, stand clear of the rotating track. Do not use too much throttle during warm-up or when track is free hanging. Entanglement and serious injury or death may result.



Do Not Operate Engine With Clutch Guard Removed

The clutch guard is designed to protect the operator from metal parts in the event the clutch should fail. Although the chance of failure is extremely remote, do not defeat the purpose of the guard by removing it. It is provided for *your* safety.



Never Run Engine With Drive Belt Removed

Operation of the engine with the belt removed can result in serious over-speed condition. Any servicing which requires operation without a belt must be done by your dealer.



Never Service Clutches Yourself - See Your Dealer

The clutch is a complex mechanism which operates at high rotational speeds. Each clutch is dynamically balanced before installation. Any tampering by the owner may disrupt this precision balancing and create an unstable condition.



Seat Back/Cargo Carrier

Do not sit on seat back or cargo area. Do not exceed carrier and rack weight limits. Cargo load affects machine steering response.



Disabled Operators

Safe operation of this rider-active vehicle requires good judgement and physical skills. Persons with cognitive or physical disabilities who operate this vehicle have an increased risk of overturns and loss of control which could result in serious injury or death.

OPERATION WARNINGS

Hydraulic Brakes

The need for a properly functioning brake is vital. Polaris snowmobiles are equipped with the highest quality hydraulic disc brake system available. The following items must be checked each time before starting the engine to assure proper operation.

Brake Lever Travel

When the brake handle is depressed (A), it should move no closer than 1/2" (1.3 cm) from the handgrip. Excessive travel indicates low fluid level or air in the hydraulic system. If the lever travel is excessive, refer to the brake bleeding information on page 69.

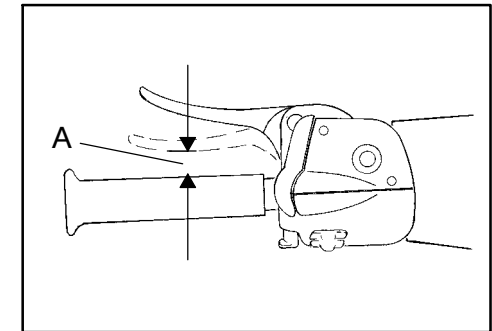

Lever Feel

A hydraulic system multiplies the force of your hand squeeze on the brake lever. Proper operation depends upon an adequate air and moisture-free supply of hydraulic brake fluid in the system. If the brake lever feels "spongy" when squeezed, the level and condition of the fluid must be checked; as well as checking for the presence of air in the fluid system. Refer to page 69 for more information or contact your dealer for service. Replace brake fluid at least every two years with Polaris DOT 3 high temperature brake fluid. All DOT 3 brake fluid is not alike. We recommend the use of Polaris brake fluid (PN 2870990).

WARNING

Continued abusive brake application with a "spongy" brake condition may cause a complete loss of brakes; which could result in severe injury or death.

Mechanical Brakes

Brake Lever Travel

Measure the clearance between the lever and brake block. Inspection should be made with the lever firmly depressed. Distance B should be no more than 3/4" (1.9 cm).

Excessive travel indicates a need to adjust the brake cable adjuster. Refer to the mechanical brake adjustment information on page 72.

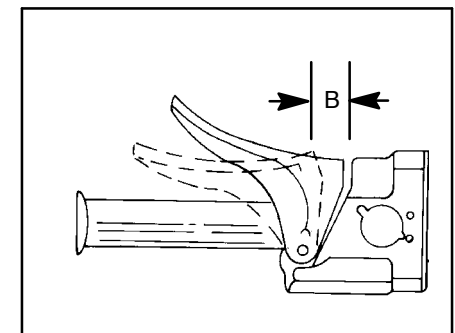

OPERATION WARNINGS

Park Brake Lever Lock

1. Brake Handle
2. Park Brake Lever Lock
(Not all models are equipped with a park brake)
3. Master Cylinder Reservoir
4. Master Cylinder Cover
5. Fluid Level Indicator

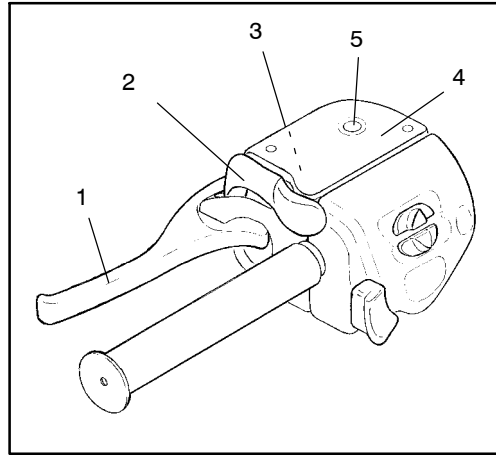

Your snowmobile has a brake brake lever lock. It is located over the brake lever. Use the brake lever lock only when you want the machine to remain stationary (e.g. when parked on an incline) for a period of five minutes or less. To apply lock, squeeze brake handle and push forward on brake lever lock. Hold lock forward and release brake handle. To release lock, squeeze brake handle until lever returns to the unlock position. The park brake light on the console will be lit when the park brake lever lock is set and the engine is running. It is also lit when the service brake is in use. If the park brake light does not come on when park brake or service brake is in use, have it serviced by your dealer.

WARNING

If the park brake lever lock is left partially or entirely engaged while riding the snowmobile, it could cause overheating of the brakes which could result in damage to the brake caliper. In extreme cases it could cause a fire which could result in serious injury or death.

Check to See That the Hood is Securely Latched

The hood of the snowmobile protects the operator from moving parts as well as aiding in sound emission control and various other functions. *Under no circumstances* should your snowmobile be operated with the hood open or removed.

OPERATION WARNINGS



Auxiliary Shut-Off Switch

Check auxiliary shut-off switch for proper operation. Push down to stop engine. Pull up to release and start engine.



Tether Switch (accessory on all models)

Check tether switch for proper operation.



Remove Ignition Key

Don't tempt anyone to steal or ride your snowmobile without permission by leaving the key in the ignition.



Lighting Check

Check headlight high and low beam, taillight and brake light for normal operation.



Check Surroundings to Verify Clear Operating Area

It is most important to assure yourself that you have a clear area all around your snowmobile, including an area clear of bystanders. Remember that the possibility always exists of some sideways vehicle movement, or a little more throttle than intended; or debris may be thrown by the track. If you are assured of a clear area surrounding you before you start, you can devote your full attention to operating the snowmobile.



Be Seated and in Position to Control the Vehicle

Improper operator position on the snowmobile can be the source of serious injury. Remember that operating a snowmobile does require skill and balance for proper control, and an improper position can seriously reduce your ability to control your snowmobile. The style of positioning will vary from person to person as they become more skilled; but under most conditions the proper position is to be seated, feet on the running boards, and in a comfortable position for proper throttle, brake, and steering control.



WARNING

Your snowmobile is propelled by a revolving track which must be partially exposed for proper operation. Serious injuries may be caused by operator carelessness resulting in hands, feet, or clothing becoming entangled in the track. Be alert. Remember, being properly seated keeps you clear of the track.

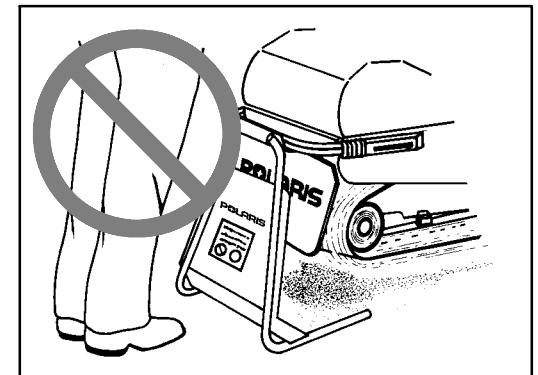

Never hold the snowmobile up or stand behind it while warming up the track. A loose track or flying debris could cause serious personal injury or death.

OPERATION WARNINGS

Stop Engine Before Attempting Adjustments

WARNING

The snowmobile engine compartment contains moving parts. Shields and guards have been provided for your safety, but it is still possible to carelessly get your hands or fingers into a moving belt or a rotating shaft. For this reason *never* attempt adjustments with the engine running. Serious personal injuries can result. The proper method is to turn off the ignition, raise the hood, make the adjustment, secure shields and guards, secure the hood, and then re-start the engine to check its operation. The same is true of track alignment. If the track must be re-aligned, it is recommended that this service be performed by your dealer.

Always Wear Clothing Designed for Snowmobiling

Clothing designed for snowmobiling is warm, comfortable and safe.

WARNING

Always wear an approved helmet and eye protection. Don't wear loose clothing or long scarves because they can easily become entangled in moving parts. Also, be aware of the weather forecast and especially the wind chill. A table is provided on page 19 for your reference. Be prepared. Be warm and comfortable.



Know the Limitations of the Machine and Your Skills as a Driver

- Observe state and local laws governing snowmobile operation. They have been established for your protection.
- Traveling at night requires extra caution. Check both headlight and taillight to ensure proper operation. Do not "over-drive" your headlight beam. A good rule to follow is to be able to bring your machine to a stop in the distance illuminated by the headlight. High speed driving at night is dangerous and unwise, and could result in severe personal injury or death.
- Be courteous to oncoming traffic by dimming your headlights and lowering your vehicle speed. Your snowmobile is equipped with a high output head lamp system that can cause discomfort to operators of oncoming vehicles if the headlight is not dimmed.

OPERATION WARNINGS

- Wire fences are a serious hazard. Unless you are thoroughly familiar with an area, you should always be on the alert for fences. Single strands are especially dangerous, since there can be a great distance between posts. Guy wires on utility poles are also difficult to distinguish. Reduce speed when traveling near poles, posts, or other obstacles. *Be especially alert if you are snowmobiling after dark.*

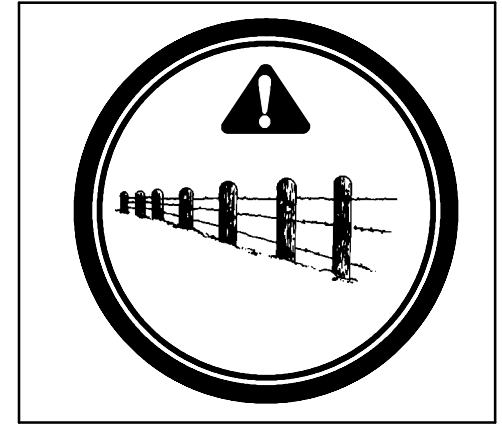

- When travelling on lakes and streams that are strange to you, always check with local residents or authorities for general information on conditions. Thin ice, open water, and snowmobiles are not compatible. Before riding your machine on a frozen body of water, be sure that the ice is thick enough to support the machine and its operator as well as the force created by a moving vehicle. Variations in snow depth and/or water currents can result in uneven ice thickness. Use common sense and good judgment at all times as drowning may result if you and the snowmobile break through the ice.

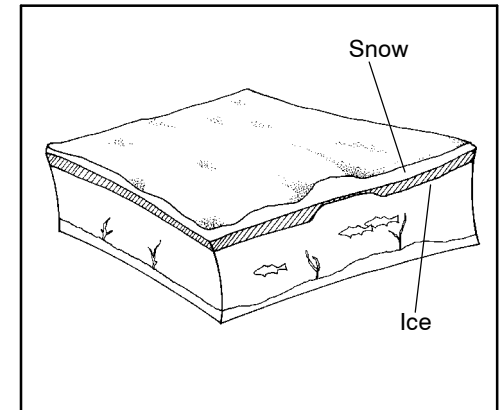

OPERATION WARNINGS

- Remember, the sound of your machine will drown out the sound of approaching vehicles. Look ahead, behind, and to the sides before turning or crossing railroad crossings or highways. Steep embankments may also hide your view. Always leave yourself a way out. *Make sure the way is clear before you cross railroads and other roads and highways.*

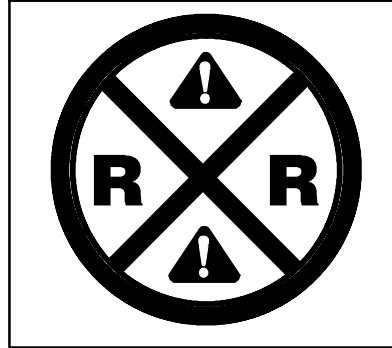

- Drive defensively when traveling in a group of snowmobiles to avoid accidents. Don't tailgate. Allow ample stopping distances.
- Always be alert and pay attention to the trail ahead of you. Multiplying speed (MPH) by 1.5 will equal the approximate number of feet per second your machine travels. If your speed is 40 MPH, your machine is travelling approximately 60 feet per second. This means that if you look back for only two seconds, your machine will travel about 120 feet. If your speed is 60 MPH, your machine will travel approximately 180 feet in two seconds.
- When teaching inexperienced operators to ride, set up a nearby predetermined course. Make sure they know how to drive and control the snowmobile before you allow them to make longer distance runs. Teach them proper snowmobile courtesy. Enroll them in a driver's training and safety course sponsored by a local or state organization.

OPERATION WARNINGS

Windchill/Temperature Charts

The following information is provided as a guide to determine what temperatures are dangerous when riding your snowmobile.

WIND CHILL CHART (°F)

Estimated Wind Speed in MPH	Actual Thermometer Reading (°F)											
	50	40	30	20	10	0	-10	-20	-30	-40	-50	-60
	Equivalent Temperature (°F)											
Calm	50	40	30	20	10	0	-10	-20	-30	-40	-50	-60
5	48	37	27	16	6	-5	-15	-26	-36	-47	-57	-68
10	40	28	16	4	-9	-21	-33	-46	-58	-70	-83	-95
15	36	22	9	-5	-18	-36	-45	-58	-72	-85	-99	-112
20	32	18	4	-10	-25	-39	-53	-67	-82	-96	-110	-124
25	30	16	0	-15	-29	-44	-59	-74	-88	-104	-118	-133
30	28	13	-2	-18	-33	-48	-63	-79	-94	-109	-125	-140
35	27	11	-4	-20	-35	-49	-67	-82	-98	-113	-129	-145
40	26	10	-6	-21	-37	-53	-69	-85	-100	-116	-132	-148
Wind Speeds Greater Than 40 MPH Have Little Added Effect	Little Danger (For Properly Clothed Person)				Increasing Danger				Great Danger			
	Danger From Freezing of Exposed Flesh											

WIND CHILL CHART (°C)

Estimated Wind Speed in KPH	Actual Thermometer Reading (°C)									
	5	0	-5	-10	-15	-20	-25	-30	-35	-40
	Equivalent Temperature (°C)									
0	5	0	-5	-10	-15	-20	-25	-30	-35	-40
10	1	-4	-11	-16	-22	-27	-33	-38	-45	-50
20	-4	-9	-17	-23	-29	-36	-42	-48	-54	-61
30	-7	-13	-21	-28	-35	-42	-48	-55	-63	-69
40	-9	-16	-24	-32	-39	-47	-53	-61	-69	-76
50	-11	-18	-26	-34	-41	-49	-57	-64	-73	-80
60	-12	-19	-27	-35	-43	-51	-59	-66	-75	-82
70	-13	-20	-28	-36	-44	-52	-60	-68	-76	-84
Wind Speeds Greater Than 70 KPH Have Little Added Effect	Little Danger (For Properly Clothed Person)				Increasing Danger				Great Danger	
	Danger From Freezing of Exposed Flesh									

OPERATION WARNINGS

Cold Weather Driveaway

Whenever the machine has been parked for some length of time, especially overnight, always shake loose the skis and track before attempting to put the machine into motion. The throttle should always be opened with enough authority to put the machine into motion, staying within safety limits and with respect to a passenger, on a two passenger machine.

Powder Snow Operation

Your Polaris is designed to operate best on snow. Maneuverability is attained by the steering, skis, and the shifting of your body weight. Maximum control will be attained by shifting body weight. Maneuverability will change for lighter operators or machines carrying a load or a passenger where allowed.



CAUTION: Do not operate for prolonged periods on blacktop, gravel, or glare ice.

It is essential that your machine be operated under conditions with adequate snow cover, as snow provides the only lubrication for the power slide suspension and, on liquid cooled models, cooling for the engine. Failure to do so will result in excessive wear and damage to the slide rail and track and/or engine.

If the machine becomes stuck in snow, free the running board area, and step down the snow in front of the machine so that when the throttle is opened the machine will be able to climb up and over. The operator can then mount the machine and continue.



WARNING: Snow and ice buildup in the underhood area can cause interference with the steering function.

Before driving, be sure that ice and snow are not interfering with full left and right steering by manually turning the skis to the left and right. If difficulty is encountered, check for ice and snow buildup which may be obstructing the steering linkage. Snow screen and bib kits are available through your dealer to help reduce snow and ice buildup.

NOTE: The ability of the machine to travel in adverse conditions will improve as the operator gains experience.

OPERATION WARNINGS

Hard Packed Snow



Steering and braking control are substantially reduced under packed snow or icy conditions.

Excessive shifting of operator body weight when turning on hard packed snow or slippery surfaces can result in loss of vehicle control and serious injury. Reduce speed as required to maintain control under these conditions.

Ice



It is dangerous to operate on ice or under slippery conditions. If ice or slippery conditions are unavoidable, use extreme caution and operate at speeds no faster than a walk. Never attempt an abrupt change of direction on a slippery surface. The chance of "spin-out" increases under these conditions.

Before riding your snowmobile on a frozen body of water, be sure that the ice is thick enough to support the machine and its occupant(s) as well as the force that is created by a moving vehicle. Severe injury or death can result if the snowmobile and/or its occupant(s) break through the ice.

OPERATION WARNINGS

Hilly Terrain

Exercise caution and good judgement when travelling in hilly terrain.

Crossing a Slope (Sidehilling)

 **WARNING**

Sidehilling can be very dangerous and is not recommended for inexperienced snowmobilers.

Crossing the face of a slope (sidehilling) requires the operator to position his/her weight in order to maintain proper balance. Kneel with the knee of the downhill leg on the seat and the foot of the uphill leg on the running board. This position makes it easier to shift your weight as needed. As you travel across the slope, lean uphill to position your weight on the uphill side.

OPERATION WARNINGS

Riding Uphill

Hill climbing may be accomplished by using one of two methods, depending upon the steepness of the hill.

Sidehilling may be used if there are few obstacles on the hill. The operator should assume a kneeling position (as in **Sidehilling**), keeping body weight on the uphill side at all times. Maintaining a steady, safe speed, approach the hill at an angle, continuing as far as possible in this direction; then switch to the opposite angle and riding position.

The *direct climb* method requires extreme caution. The operator should assume a standing position with body weight kept low and forward, accelerating before the start of the climb and then releasing throttle pressure enough to prevent track slippage.

In either type of climb, the operator must slow down when reaching the crest of the hill. Be prepared to react to obstacles, sharp drops, or other people or vehicles which may be on the other side of the hill.



If you are unable to continue up a hill, turn the machine downhill before it loses momentum. If this is not possible, spin the track just enough to dig in so the machine won't roll back down the hill. Stop the engine and set the parking brake (if equipped). Keeping away from the downhill side of the machine, pull the rear of the snowmobile around, pointing the machine back downhill. Once the snowmobile is pointed downhill, mount the machine, restart the engine, release the parking brake, and descend the hill.

Riding Downhill

When riding downhill, keep speed at a minimum. It is important to apply just enough throttle to keep the clutch engaged while descending the hill. This will allow use of the engine's compression to help slow the machine, and keep the snowmobile from rolling freely downhill.



Use extreme caution when applying the brake during a descent. Excessive braking will cause the track to lock, resulting in loss of control.

OPERATION WARNINGS

Responsible Driving

If you operate the snowmobile improperly, you will cause situations which will exceed your driving skills. Each snowmobile handles differently, and even if you are a seasoned driver, it is strongly recommended that you spend some time getting the feel for this particular machine before attempting ambitious maneuvers. If you are new to snowmobiling, take enough time to acquaint yourself with the machine and what it will and won't do under various conditions.



Acquire a feel for your machine before attempting ambitious maneuvers. The snowmobile depends on your body position for proper balance in executing turns, traversing hills, etc. It's best to start on a smooth level area to begin building your operating experience.



Before you let someone else use your snowmobile, be sure you know the extent of their operating skills. Check to see if they have taken a snowmobile safety course and have an operator's certificate. For their protection, as well as yours, make sure they take a snowmobile safety course. Everyone can benefit from the course.



Don't "jump" your snowmobile. Jumping can injure your back because of spinal compression. The seat and suspension of your snowmobile have been designed and constructed to give you protection, but they do have limits. Your snowmobile is not intended for this kind of use.

PRESERVATION OF THE ENVIRONMENT

We recommend that you drive your snowmobile with consideration for the protection and preservation of our environment.

Noise Level

Probably the most publicized subject with regard to snowmobiles is noise. The Society of Automotive Engineers (SAE), which is the standard-setting body for snowmobiles, has recommended that snowmobiles conform to prescribed sound levels. Your Polaris snowmobile has been engineered to conform to these SAE standards.

In order to be meaningful, all regulations require the cooperation of the snowmobile driver. Muffling systems, designed to reduce noise levels, should not be altered or removed. Snowmobile drivers must be aware that they have a public responsibility to operate their snowmobiles with concern for others. As a snowmobile operator you may not realize the sound of your snowmobile may annoy non-snowmobilers. We are attempting to do our part through the manufacture of quieter machines, and we also ask your help in the effort to further reduce the impact of noise.

Air Pollution

As a part of Polaris' plan for the snowmobile's compatibility within the environment, our engineers are investigating ways to reduce emission levels of two-stroke engines. We expect our efforts to lead to the reduction of potential air pollution.

In addition to technological research, we also suggest that governmental agencies, manufacturers, distributors, dealers, ecologists, and other interested parties work together to develop data on environmental topics. We will continue to participate in this type of study so that someday we may find the answers to these difficult issues.

Environmental Protection

As part of the continuing environmental education campaign, we are encouraging state and provincial governments across the snowbelt to adopt rigorous safety training programs which also encourage protection of our environment, wildlife and vegetation. Snowmobile clubs and other organizations are working together to protect our environment. It is very important that we encourage them as well as become actively involved ourselves.

Respect your snowmobile;
respect your environment;
and you will earn
the respect of everyone.

IDENTIFICATION AND SPECIFICATIONS

Vehicle Nomenclature

Refer to illustrations on following pages. **NOTE:** Illustrations are a general representation. Your model may differ.

- | | |
|-------------------------------|--------------------------------------|
| 1. Hood | 13. Suspension |
| 2. Headlight | 14. Nosepan |
| 3. Windshield | 15. Trailing Arm |
| 4. Handlebar | 16. Skis |
| 5. Seat | 17. Front Bumper |
| 6. Storage/Rear | 18. Console |
| 7. Taillights | 19. Vehicle I.D. Number (Right Side) |
| 8. Backrest | 20. Rear Bumper |
| 9. Tunnel Extension | 21. Passenger Hand Hold |
| 10. Passenger Hand Hold Strap | 22. Lifting Hand Hold |
| 11. Track | 23. Snow Flap |
| | 24. Mountain Bar |

Vehicle Nomenclature, Cont.

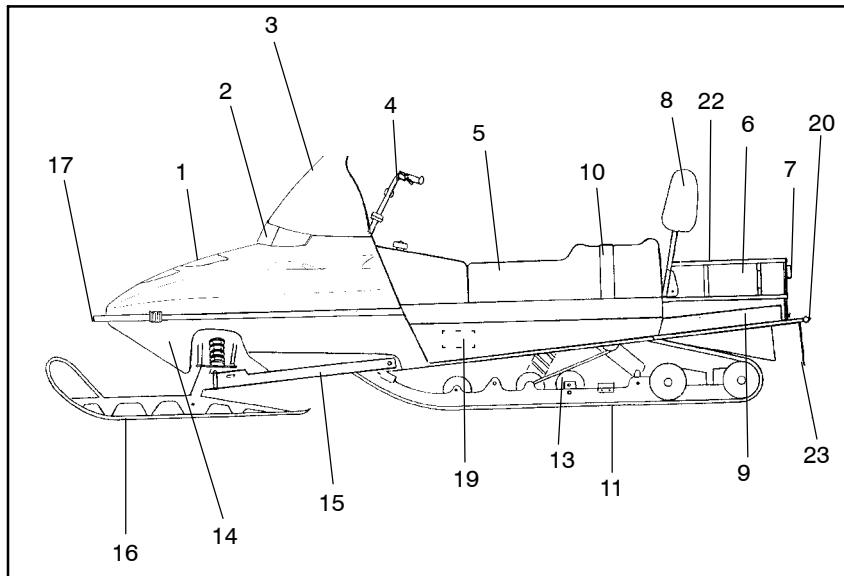

IDENTIFICATION AND SPECIFICATIONS

Vehicle Nomenclature, Cont.

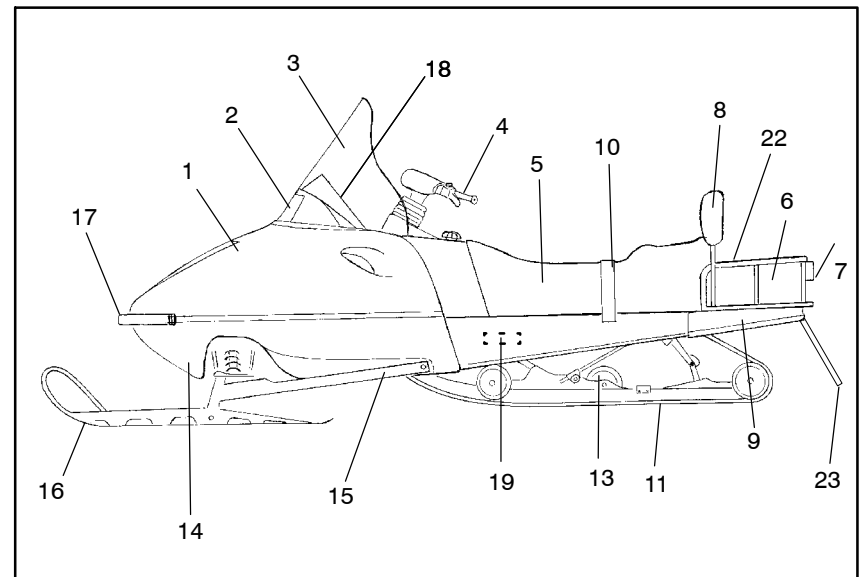
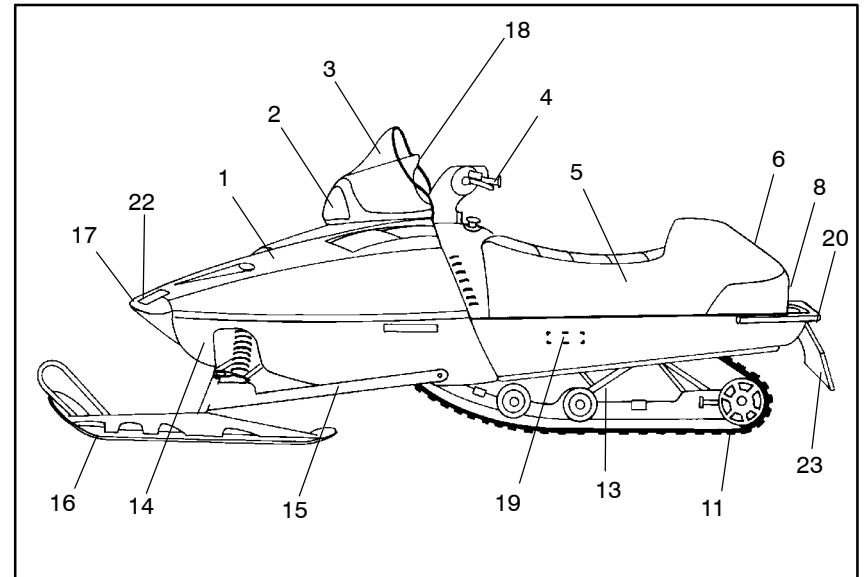

IDENTIFICATION AND SPECIFICATIONS

Vehicle Nomenclature, Cont.

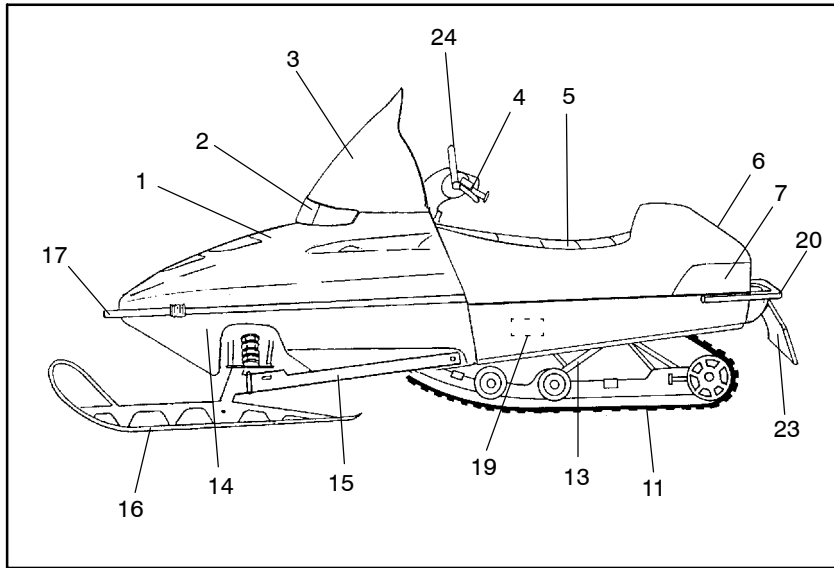

IDENTIFICATION AND SPECIFICATIONS

Controls and Instruments

General Representations
Your Model May Differ

1. Headlight Dimmer Switch (2 Position)
2. Fuel Filler Cap/Gas Gauge
3. Auxiliary Shut-Off Switch (Push/Pull). Operation found on page 40.
4. Throttle Control
5. Recoil Starter Handle
6. Choke Control
7. Ignition Switch
8. Tachometer (may include indicator / warning lights)
9. Speedometer (may include indicator / warning lights)
10. Brake Lever
11. Low Oil Warning, Brake Light, High Beam, Temp, premium fuel options
12. Accessory Indicators
13. Safety Decals
14. Hood Hold Down
15. Handlebar Grip Warmer Switch
16. Thumbwarmer Switch
17. Thumbwarmer/Handwarmer Switch
18. Reverse Lever
19. Fuel Gauge
20. Temperature Light
21. Tether Switch
22. Power Plug
23. Electric Shock Absorber Gauge

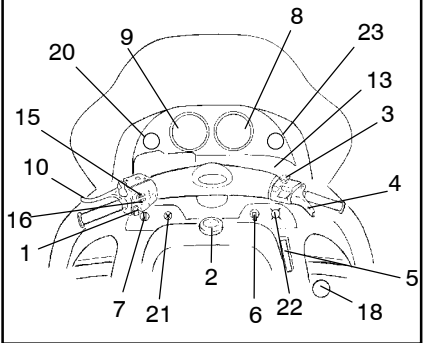
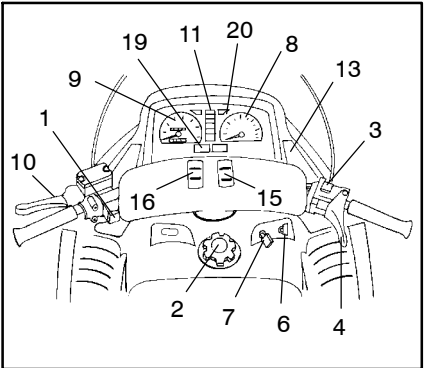
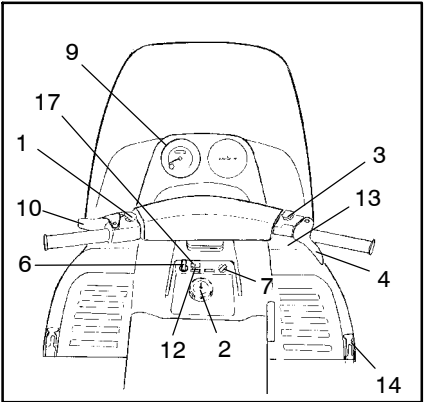

IDENTIFICATION AND SPECIFICATIONS

Backrest

1. Backrest Cushion Adjuster
2. Backrest Adjuster Cable
3. Grab Bar Adjustment Knob
4. Passenger Handwarmer Switch
5. Wind Deflector
6. Backrest Adjustment Lever
7. Passenger Hand Hold

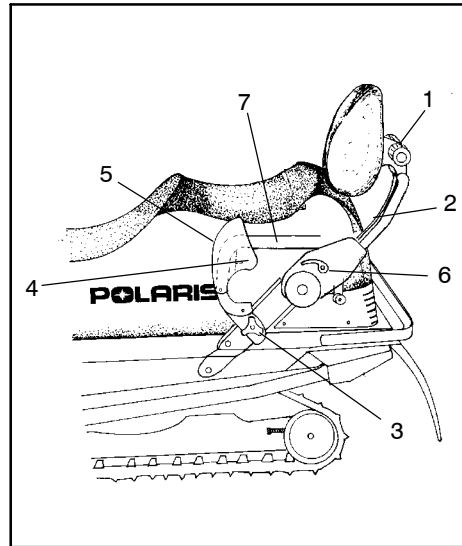

Carburetion

Proper carburetor adjustment is critical, since a mixture too lean (too much air, too little fuel) will result in overheating of the combustion chamber causing pre-ignition of the fuel. This results in piston burning, bearing failure, or complete engine failure. A lean mixture can be the result of fuel line restrictions, foreign matter in the carburetor, clogged fuel filter, etc.

A mixture too rich (too much fuel, too little air) is also unfavorable because it can foul plugs and cause generally poor engine performance.

All carburetors have been pre-set at the factory for adequate fuel supply. Higher altitude operation may require different adjustment and settings.

RMK models are pre-set to operate at altitudes of 6000-9000 feet above sea level.

▲ WARNING

Carburetor adjustments must be performed by your dealer, since mistakes can result in possible operator safety hazards as well as serious engine damage.

Remember, correct setup provides engine RPM within its given power band at full throttle settings and also provides maximum efficiency and operation at all other throttle openings. Your dealer has the training and tools required to perform any adjustments for you.

▲ WARNING

Engine damage may result if jetting or clutching is wrong. Never service clutches yourself. See your dealer.

Drive System

1. Engine
2. Torque Converter (Drive Clutch)
3. Driven Clutch
4. Drive Belt (Neutral Position)
5. Drive Belt (Full Upshift Position)
6. Upper Chaincase Sprocket
7. Chain
8. Lower Chaincase Sprocket
9. Chaincase Oil Level
10. Drive Shaft
11. Track

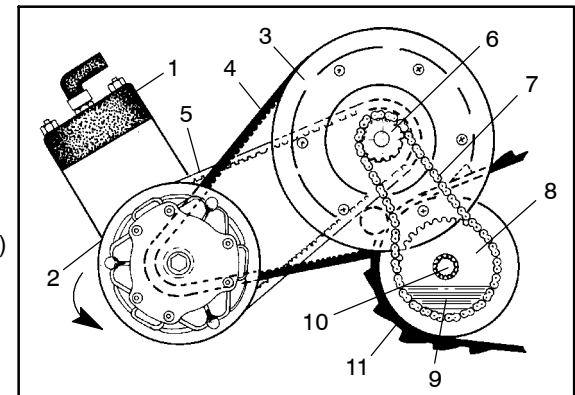

OPERATION

Lubrication

The fuel and oil which enter the engine through the fuel and oil injection systems provide the only source of engine lubrication, and must be of the highest quality.

You can understand the importance of proper lubrication when you realize that at 6000 RPM the crankshaft is rotating 100 revolutions per second.

Premium 2-Cycle Lubricant

The only oil recommended for this fuel system is Polaris brand oil. **CAUTION: Engine warranty coverage may become void if other brands are substituted.**

Polaris Premium Gold Synthetic Lubricant is the most advanced formulation of oil available for today's 2-cycle engines. Over twenty months of lab and field tests have resulted in a new generation of 2-cycle lubricant. Polaris Premium 2-Cycle Lubricant addresses the problem of lower quality fuel; keeping ring grooves cleaner with less ring sticking and providing improved overall engine cleanliness. With new generation lubricity technology, it excels in meeting the lubricity demands of today's faster, more precisely engineered 2-cycle engines. It is the optimum oil recommended for liquid 2-cycle engines and performs well in all air cooled 2-cycle engines. We believe this oil is the best product available in the market today, and strongly recommend its use in all of our products.

Never mix other brands of oil since they may be incompatible, resulting in sludge formation, filter blockage and reduced cold weather flow rates.

Oil Injection System

The fuel-to-oil mix ratios are controlled by the oil pump and the movement of the oil pump arm. The fuel-to-oil mix ratio corresponds to the engine's RPM and throttle valve opening.

Always fill the oil reservoir when refueling.

NOTE: Mix two pints of Polaris injection oil to the first tankful of gasoline. In addition to the lubrication supplied by the injection system, this will ensure proper engine break-in.

CAUTION:

Check the oil tank level often during the first tankful of fuel. If the oil level doesn't go down, contact your dealer immediately. Continue using premixed fuel until the oil injection system can be inspected.

Low Oil Indicator Light

The low oil indicator light is standard on most models.

CAUTION:

When the low oil indicator light is on, it indicates that oil must be added before further operation of the snowmobile. Visually check the oil level in the bottle. The engine can be operated as long as oil is visible in the oil tank. If oil is not visible, continued operation may cause severe engine damage.

▲ WARNING

Never mix brands of two cycle oil. Serious chemical reactions can occur, causing injection system blockage resulting in severe engine damage and voiding of engine warranty.

CAUTION:

Always maintain the oil level in the oil tank above the low level line. The low oil indicator light will indicate when to add oil. However, the oil level should always be checked when refueling. **NOTE:** In the illustration, * indicates low oil level.

This is especially important when the machine is operated in mountainous terrain. Maintaining the proper oil level will prevent system aeration and possible loss of pumping action, which could result in engine damage.

NOTE: Always use a Polaris oil cap, never substitute. Your Polaris oil cap may be vented to allow proper oil flow.

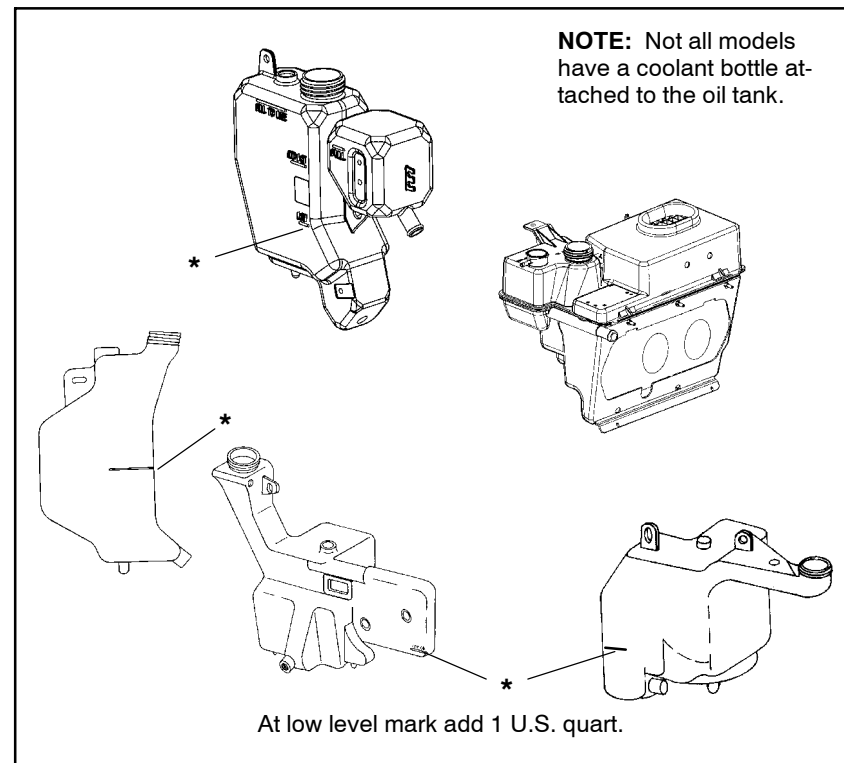







OPERATION

Fuel

WARNING

Gasoline is extremely flammable and explosive under certain conditions.

-  Always stop the engine and refuel outdoors or in a well ventilated area.
-  Do not smoke or allow open flames or sparks in or near the area where refueling is performed or where gasoline is stored.
-  Do not overfill the tank. Do not fill the tank neck.
-  If you get gasoline in your eyes or if you swallow gasoline, see your doctor immediately.
-  If you spill gasoline on your skin or clothing, immediately wash it off with soap and water and change clothing.
-  Never start the engine or let it run in an enclosed area. Gasoline powered engine exhaust fumes are poisonous and can cause loss of consciousness and death in a short time.

WARNING

The engine exhaust from this product contains chemicals known to cause cancer, birth defects or other reproductive harm.

Fuel

The fuel used in the Polaris engine is as important to engine life and performance as the lubricant used.

Most Polaris engines are designed to run on 87 octane non oxygenated or 89 octane oxygenated pump gasoline. There is a great deal of variability in the quality of the 87 octane gasoline available across the country. We encourage the use of premium fuel when possible. **NOTE:** XCR models *require* premium gasoline.

Consult your Owner's Manual Supplement for specific minimum octane requirements.

Premium Fuel Switch

Some Polaris snowmobiles are equipped with a key function that will adjust the timing on the machine as you change fuels.

Most high performance machines require the use of premium fuels. When premium fuel is not available, there is a risk of engine damage when other fuels are substituted.

When using fuels with a pump posted octane rating of 91 or higher, turn the key switch to "ON/PREM". When the engine is started a yellow "Premium Fuel" light illuminates on the instrument panel. When the key is in this position, the fuel **must** be a minimum of 91 octane.

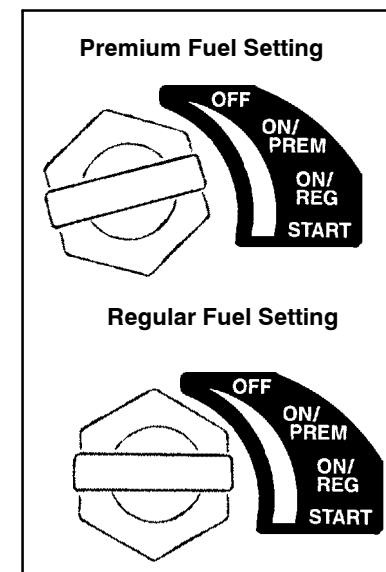

If you are uncertain about the quality or octane rating of the fuel you are using, turn your key switch to "ON/REG". The "Premium fuel" light will go out. This setting will adjust the timing of your engine to run on fuels with 87 octane or higher. Polaris does not recommend using fuel with lower than 87 octane.

Running your machine on "ON/REG" will protect your engine from damage caused by low octane fuels. It is very important to the life of your engine that you are aware of and use this feature.

OPERATION

Fuel Reserve Capacity

On equipped models, when the fuel gauge reads “RES”, there are approximately 2 gallons of fuel left in the tank.

Fuel System Deicers

If you are using non-oxygenated fuel, Polaris recommends the regular use of Iso-propyl base fuel system deicer (Polaris PN 2870505). Add 1 to 2 ounces per gallon (8-16 milliliters per liter) of gasoline to prevent engine damage resulting from fuel system icing and lean mixtures. Never use deicers or additives that contain *methanol*. Use *only* isopropyl fuel system deicers.

If using oxygenated fuel containing ethanol, additional alcohol deicers or water absorbing additives are not required and should not be used.

CAUTION:

Prolonged exposure to petroleum based products may damage paint. Always protect painted surfaces when working with fuel.

It is recommended that plastic side panels be removed whenever servicing requires tipping the machine on its side for a period of fifteen minutes or more.

Tool Pouch Clip

Some Polaris snowmobiles are equipped with a tool pouch clip which is located inside of the flap on the back of the seat. Using this clip will secure the tools, preventing them from freely bouncing around during snowmobile use.

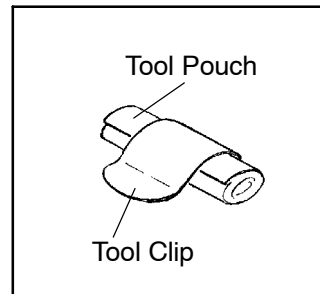

Engine Break-In

No single action on your part is as important to long, trouble-free machine life as proper break-in for a new or rebuilt engine. Familiarize yourself and others with the following procedure for your Polaris snowmobile.

Premix the first tank of gasoline with one pint of Polaris injection oil for each 5 gallons of fuel. This, in addition to the lubrication supplied by the injection system, will assure proper engine break-in. **IMPORTANT:** Before operating with unmixed fuel, make sure oil is being drawn from the oil tank.

WARNING

- Never mix brands of two cycle oil. Serious chemical reactions can cause injection system blockage, resulting in severe engine damage and voiding of engine warranty. The only oil recommended for this system is Polaris injection oil. This oil has been specially formulated for all temperatures and has extreme cold flow characteristics.
- Do not operate at prolonged full throttle for the first three hours of operation. Vary the throttle openings and machine speeds. This will reduce friction on all close fitting machined parts and allow them to break in slowly without damage.
- Avoid operating on ice or hard-packed surfaces, roads, etc. The absence of lubrication and cooling by snow will lead to overheating of the slide rail and track resulting in premature wear and failure. Reduce speeds and frequently drive into fresh snow to allow adequate cooling and polishing of the slide rail and track surfaces.
- Drive with extra caution during the break-in period. Perform regular checks on fluid levels, lines, and all important areas of the machine.

With a basic understanding of how the snowmobile works, and with close attention paid to maintenance tips, you will be ready to ride. Keep in mind these recommendations as well as those covered throughout this manual.

OPERATION

Pre-Starting

WARNING

Before starting the engine, always refer to all safety warnings pertaining to snowmobile operation. Never start your snowmobile without checking all components to be sure of proper operation. See Operation Warnings beginning on page 10.

Important safety items include, but are not limited to:

- Throttle system
- Brake system
- Steering system

These systems must be checked each time before starting the engine. Incorrect adjustments, damage, or excessive wear due to neglect could result in personal injury and/or damage to the snowmobile.

Starting a Cold Engine (Manual Start)

1. Turn key to “On”.
2. Pull kill switch (shut-off switch) up to “run” position.
3. Flip choke toggle to “Full On” position.
4. Grasp starter handle and pull slowly until recoil engages; then pull to start.

CAUTION:

Do not pull the starter rope to its full extended position or allow it to snap back into the housing as damage can result.

NOTE: Do not depress throttle until engine starts.

5. After engine starts, the choke toggle should be flipped to “Off” position. If the engine slows or wants to stop, intermittent choking to the “Half On” position is helpful.

Starting a Cold Engine (Electric Start)





1. Flip choke toggle to “Full On” position.
2. Pull kill switch (shut-off switch) up to “run” position.
3. Turn key to “Start” position and crank engine.
4. After engine starts, release key to “On” position and flip choke toggle to “Off”. If the engine slows or wants to stop, intermittent choking to the “Half On” position is helpful.

NOTE: Do not depress throttle until engine starts.

Starting a Warm Engine

1. Turn key to "On".
2. Pull kill switch (shut-off switch) up to "run" position.
3. Grasp starter handle and pull slowly until recoil engages; then pull to start.

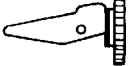
If the engine does not start on the first pull, slightly depress the throttle with your left hand (no more than 1/4" open), and pull the rope with your right hand. As soon as the engine starts release the throttle.

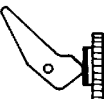
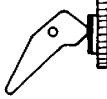
CHOKE TOGGLE POSITIONS	
Off	 or 
Half On	 or 
On	 or 

OPERATION

Auxiliary Engine Shut-Off Switch

To stop the engine in an emergency, push down on the auxiliary shut-off switch (A). This will ground out the ignition and bring the engine to a quick stop. To restart the engine the switch must be pulled up to the "On" position.

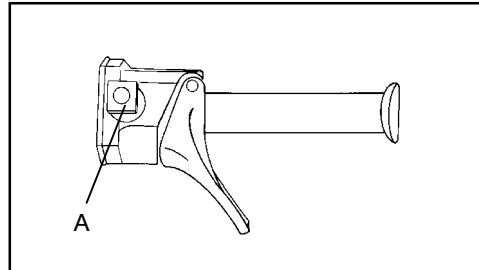

Throttle Safety Switch

Test the throttle safety switch system on a daily basis before the machine is used.

While seated in a normal riding position, and with the engine idling, hold the throttle lever stationary by exerting pressure on the pivot pin in the direction shown in the illustration (B). Apply a slight amount of throttle opening. A properly functioning switch *must* shut down the engine.

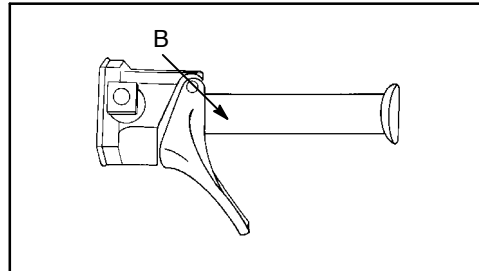

The throttle safety switch is designed to stop the engine whenever all pressure is removed from the throttle lever and the throttle cable or valves do not return to the normal closed position.

WARNING

If the throttle safety switch does not shut off the engine in the event of a carburetor/throttle system malfunction, immediately push down the auxiliary shut-off switch. Do not start the engine until the malfunction has been corrected by your dealer.

If the snowmobile engine stops abruptly when the throttle lever is released, use the following procedure.

1. Turn the ignition switch to "Off".
2. Visually inspect the throttle cable and carburetor(s) to determine what caused the safety switch to activate.
3. Test the throttle lever by compressing and releasing it several times. The lever and cable must return to the idle position quickly and completely.

WARNING

If the throttle lever does not work properly, *do not* start the engine.

4. If the throttle lever operates properly, turn the ignition switch on and go through normal starting procedures.
5. If the engine does not start, take the snowmobile to an authorized Polaris dealer for service.

If excessive play develops in the throttle cable, the safety switch may be activated, preventing the engine from starting. Contact your dealer.

If the engine does not start, and throttle safety switch malfunction is suspected, return the machine to an authorized Polaris dealer for service. If an emergency exists and it is necessary to start the engine, the throttle safety switch and auxiliary shut-off switch may be disconnected from the wire harness.

WARNING

With the throttle safety switch and auxiliary shut-off switch disconnected, the ignition key switch must be used to shut off the engine. *Do not* continue to operate the machine with the throttle safety switch disconnected. Return the machine to an authorized Polaris dealer for service as soon as possible.

OPERATION

Emergency Stopping Procedures

The following chart lists methods for stopping the engine in the event of an emergency.

SYSTEM	WHAT IT DOES	THROTTLE CONDITION
Ignition Switch	Interrupts ignition circuit	All
Brake	Slows drive shaft	All
Choke	Floods engine	1/2 throttle or less
Auxiliary Shut-Off Switch	Interrupts ignition circuit	All
Throttle Safety Switch	Interrupts ignition circuit	All
Tether Switch (Option)	Interrupts ignition circuit	All

Refer to page 40 for more information on the auxiliary shut-off and throttle safety switches.

Emergency Starting Procedure

Your machine comes with a tool kit containing essential tools for emergency use. In the event the recoil starter system should fail, take the emergency start strap from the kit and proceed as follows:

1. Open clutch guard.
2. Push on the inner sheave of the secondary clutch and rotate clockwise slightly to relieve belt tension. This allows for easier starting.
3. Starting at one of the tower struts, wind the strap counterclockwise around the clutch as shown.

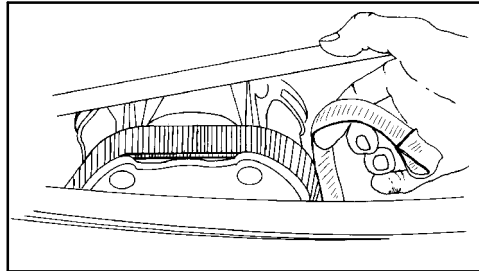

▲ WARNING

Do not wind the strap around your hand. Severe injury could result.

4. Pull the strap using a sharp, crisp pull so the strap comes free of the clutch.

CAUTION:

Keep all people clear of the snowmobile when using the emergency starting procedure.

Pre-ride Warm Up

The following steps must be taken to ensure proper warm up of the engine, drive train and track.

With the snowmobile securely supported by the rear bumper, and approximately 4" (10 cm) off the ground, use the following procedure.

1. Start the engine and allow it to warm up two to three minutes.

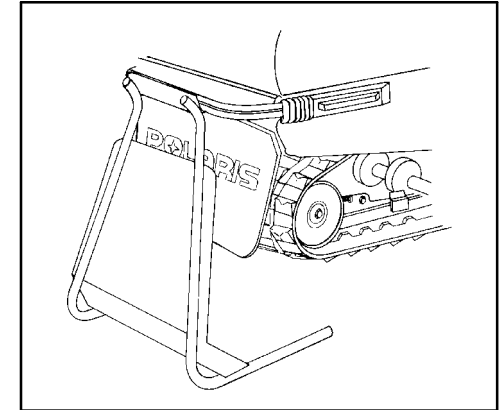

WARNING

Be sure the rear support is stable. Stand clear of the front of the machine and the moving track. Never hold the snowmobile up or stand behind it while performing this procedure. Do not use too much throttle during warm up or when track is free-hanging. A loose track or flying debris could cause serious personal injury or death.

2. Engage the drive system abruptly and allow it to rotate the track several revolutions. **NOTE:** The outside temperature will determine the amount of track warm-up required.
3. Shut off the engine and remove the rear support.
4. Grasp the skis by their front loops and move from side to side. This will loosen frozen snow from the ski bottoms, allowing the machine to move forward more easily.
5. The engine, drive system and track are now properly warmed up and the machine can be driven following normal safety practices.
6. WideTrak models can also be warmed up with the transmission in neutral and the brake engaged. This will allow the engine to warm without engaging the drive system. **NOTE:** This should not last more than five minutes.

WARNING

Engine RPM should be at idle before shifting the transmission.

OPERATION

Towing

WARNING

For your safety, the proper function of a tow hitch must be understood before attempting its use.

Do not tow toboggans, sleds, saucers, or any type of vehicle with a rope. No braking power can be applied to an object being towed with a rope.

Only a stiff metal pole connecting the towed object and tow hitch on the snowmobile should be used. If passengers are to be towed on a toboggan or sled, ensure that the stiff connecting pole is at least four feet (1.2 meters) long to prevent any possibility of contact between the vehicle track and a person riding in the towed object.

Reduced speeds are required when towing to aid in maintaining steering and general vehicle control. Braking ability is also reduced when towing loads. Reduce speed and use caution, as braking distances will increase. Tipover can occur resulting in severe injury or death.

If a situation arises requiring the snowmobile to be towed by another snowmobile, attach the tow rope to the spindles, not the ski loops.

WARNING

Always remove the drive belt from a disabled snowmobile or shift the transmission to neutral before towing to prevent serious damage to the engine and drive system.

Daily Storage

Whenever your machine is placed in overnight or daily storage the following steps must be taken:

- Park the snowmobile on a level surface and support it at the rear so the track is suspended approximately 4" (20 cm) off the ground.
- Remove the key and cover the machine using the Polaris cover available for your model. See your dealer for more information.

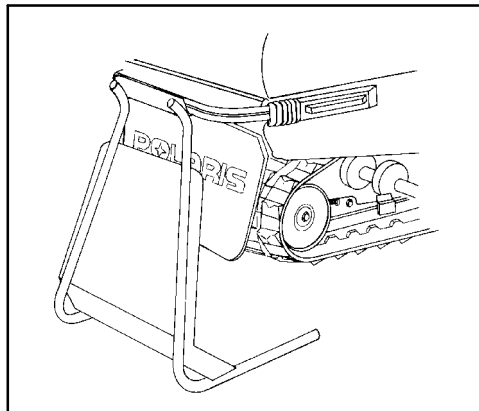

Battery Fluid

A poorly maintained battery will deteriorate rapidly. Check the battery fluid level often. The fluid level should be kept between the upper (1) and lower (2) level marks.

 To refill use only distilled water. Tap water contains minerals which are harmful to a battery.

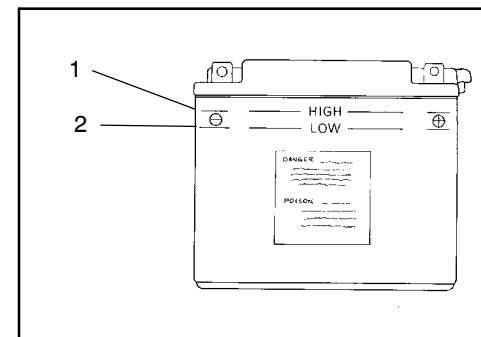

Battery Connections

Battery terminals and connections should be kept free of corrosion.

If cleaning is necessary, remove the corrosion with a stiff wire brush. Wash terminals and connections with a solution of one tablespoon baking soda and one cup water. Rinse well with tap water and dry with clean rags. Coat the terminals with dielectric grease or petroleum jelly.

 Do not allow cleaning solution or tap water to enter the battery. It will shorten the life of the battery.

WARNING

Battery electrolyte is poisonous. It contains acid!
Serious burns can result from contact with the skin, eyes, or clothing.

ANTIDOTE:

EXTERNAL: Flush with water.

INTERNAL: Drink large quantities of water or milk. Follow with milk of magnesia, beaten egg, or vegetable oil. Call physician immediately.

EYES: Flush with water for 15 minutes and get prompt medical attention.

Batteries produce explosive gases. Keep sparks, flame, cigarettes, etc. away. Ventilate when charging or using in closed space. Always shield eyes when working near batteries.

KEEP OUT OF REACH OF CHILDREN.

BATTERY

Battery Removal

CAUTION:

Whenever removing or reinstalling the battery, disconnect the negative (black) cable first and reinstall the negative cable last to avoid the possibility of explosion.

1. Disconnect hold down straps holding battery in position.
2. Remove battery vent tube from battery.
3. Disconnect black (negative) battery cable first.
4. Disconnect red (positive) battery cable second.
5. Lift the battery out of the snowmobile, being careful not to tip it sideways or spill electrolyte.

CAUTION:

If electrolyte spills, immediately wash it off with a solution of 1 tablespoon baking soda and one cup water to prevent damage to the snowmobile.

When your snowmobile is placed in storage for one month or more:

- Remove the battery.
- Charge it to the proper level.
- Store it in a cool dry place.

It is possible for batteries to freeze at the following charge conditions, resulting in cell damage.

- 100% Charged -75° F (-59° C)
- 75% Charged -24° F (-31° C)
- 50% Charged 0° F (-18° C)
- 25% Charged +13° F (-11° C)
- 0% Charged +18° F (-8° C)

Before using the battery, take it to your dealer for testing and recharging.

Battery Installation

 **WARNING**

To avoid the possibility of explosion, always connect battery cables in the order specified. Red (positive) cable first, black (negative) cable last.

1. Set the battery in its holder. Attach the hold down strap.
2. Install the battery vent line. It must be free from obstructions and securely installed. Route the vent line away from the frame and body to prevent corrosion.

 **WARNING**

If the battery vent tube is pinched or kinked, battery gases could accumulate resulting in an explosion. Avoid skin contact with electrolyte as severe burns can result.

3. Connect and tighten the red (positive) cable first.
4. Connect and tighten the black (negative) cable last.
5. Verify that cables and vent hose are properly routed.

MAINTENANCE

Polaris Recommended Owner Maintenance Program

Your Polaris snowmobile has been engineered and manufactured by skilled Polaris personnel to the highest degree of performance and reliability possible. In order to maintain this high degree of performance and reliability your Polaris must be given regular service and maintenance inspections.

We are interested in ensuring your continued enjoyment in snowmobiling with Polaris. To assure you of trouble-free enjoyment, the Polaris Owner Maintenance Program has been developed. If the recommended regular maintenance and service checks are followed, you will be doing your part in keeping your snowmobile in excellent operating condition at all times.

The recommended maintenance schedule on your snowmobile calls for a service and maintenance inspection at 150 miles (240 km), 1000 miles (1600 km), and 2000 miles (3200 km). These inspections should be performed by a qualified service technician. *All necessary replacement parts and labor incurred, with the exception of authorized warranty repairs, become the responsibility of the registered owner.*

If during the course of the warranty period parts failures occur as a result of owner neglect in performing the recommended periodic maintenance, the cost of such repairs shall be borne by the owner. Please consider the recommended maintenance program illustrated on the following pages as a preventative maintenance program designed to maintain the performance and reliability of your snowmobile in the years to follow.

Weekly Maintenance Check



For best machine performance and safe operation, check these points weekly and before any long distance trip:

1. Track alignment and adjustments
2. Chain (if applicable)
3. Gearcase oil level (if applicable)
4. Drive chain tension (rotate driven clutch back and forth, checking for excessive deflection)
5. Drive belt condition/tension
6. Brake operation, adjustment (Mechanical), fluid level (Hydraulic)
7. Headlights, tail and stop lights
8. Emergency shut off switch operation and throttle safety switch function
9. Suspension mounting bolts (tighten)
10. Steering arm and tie rod ends (check for play or looseness)
11. Ski saddle and spindle bolts (tighten)
12. Suspension front limiter strap bolts (tighten)
13. Condition of front limiter strap
14. Throttle cable condition
15. Coolant level
16. Battery fluid level

MAINTENANCE

Careful periodic maintenance will help keep your vehicle in the safest, most reliable condition. Inspection, adjustment and lubrication of important components are explained on the following chart and maintenance pages of this manual.

For continued maximum machine performance and component life, it is recommended that maintenance checks be performed at 1000 mile (1600 km) intervals.

Service and adjustments are critical. If you are not familiar with safe service and adjustment procedures, have a qualified dealer perform these operations.

NOTE: The following chart is a guide based on average riding conditions. You may need to increase frequency based on riding conditions. Inspection may reveal the need for replacement parts. Always use genuine Polaris parts available from your Polaris dealer.

ITEM	WEEKLY OR BEFORE LONG TRIP	150MI. (240 KM)	1000 MI. (1600 KM)	2000 MI. (3200 KM)	SEE PAGE
Check brake operation and adjustment	Daily				69
Test auxiliary shut-off switch	Daily				40
Test throttle safety switch	Daily				40
Throttle lever operation	Daily				10, 40
Check track alignment	X				92
Check track tension	X				90
Check chaincase oil level	X				67
Check gearcase oil level	X				68
Check drive chain tension	X				67
Check drive belt condition	X				80
Check operation of headlights, taillight, brakelight	X				15 75
Check and tighten loose suspension mounting bolts	X				101
Tighten ski saddle and spindle bolts	X				101
Check front limiter strap condition, tighten bolts	X				126
Check ski skags- replace when worn to 1/2 original diameter	X				100
Check hi-fax thickness Replace when worn (Dealer)	X				101
Tighten rear idler wheel bolts	X				92
Tighten idler adjusting bolt jam nuts	X				92
Check spark plug condition	X				56

MAINTENANCE

ITEM	WEEKLY OR BEFORE LONG TRIP	150MI. (240 KM)	1000 MI. (1600 KM)	2000 MI. (3200 KM)	SEE PAGE
Inspect coolant filter and re- place		X	X	X	
Grease ski pivots		X	X	X	52
Grease center steering arm(s)		X	X	X	52
Lubricate steering post sup- port bracket and pivot (aero- sol)		X	X	X	52
Check cylinder base stud torque on all 600 and 700 Po- laris engines. (Specification: 32 ft. lbs ± 2 ft. lbs.) (Dealer)		X	X	X	-
Grease ski spindles		X	X	X	52
Grease lower steering post pivot		X	X	X	52
Grease driveshaft bearing			X (and before storage)	X	53
Check and drain water trap			X	X	
Grease rear suspension pivot shafts			X	X	53
Grease jackshaft bearing			X (and before storage)	X	53
Lubricate throttle cable			X	X	66
Lubricate choke slide and cable			X	X	66
Check clutch alignment and offset			X	X	81
Check cooling system level and specific gravity			X	X	64
Inspect oil filter and replace			X	X	
Inspect oil line condition				X	60
Inspect fuel filter and replace			X	X	60
Check brake fluid level			X	X	70
Inspect fuel lines and replace				X	60
Inspect exhaust system for weak or missing retaining springs				X	63
Inspect exhaust pipe for cracks or damage				X	63
Inspect clutch sheaves for damage, wear, belt residue				X	80

MAINTENANCE

Present this section of your manual to your dealer each time your snowmobile is serviced. This will provide you and future owners with an accurate log of maintenance and services performed on the unit.

150 Mile (240 km) Initial Maintenance Inspection

Authorized Polaris Servicing Dealer _____

Servicing Technician _____

Date _____ Mileage _____

1000 Mile (1600 km) Maintenance Inspection

Authorized Polaris Servicing Dealer _____

Servicing Technician _____

Date _____ Mileage _____

2000 Mile (3200 km) Maintenance Inspection

Authorized Polaris Servicing Dealer _____

Servicing Technician _____

Date _____ Mileage _____

Additional Services Performed

Authorized Polaris Servicing Dealer _____

Servicing Technician _____

Date _____ Mileage _____

Type of Service _____

Additional Services Performed

Authorized Polaris Servicing Dealer _____

Servicing Technician _____

Date _____ Mileage _____

Type of Service _____

MAINTENANCE

Adjustments

It is your responsibility as the snowmobile owner to perform preventative maintenance and periodic adjustments. Many of the items listed in this section you can perform yourself. However, at times your snowmobile may need service requiring special tools and technical skills. *In these situations, we recommend you contact your Polaris dealer.*

Loose nuts and bolts can reduce your snowmobile's reliability and cause needless repairs and down time. Before beginning any snowmobile trip, a quick inspection of these areas will uncover potential problems.

Lubrication

Lubricate the following fittings with Polaris Premium grease (PN 2871066) annually or approximately every 1000 miles (1600 km). The ★ in the illustration indicates grease points.

- Spindles, left and right. The front end of the machine should be raised to permit better grease entry into the spindle area.
- Rear suspension pivot shafts. Raise the rear of unit.
- Lubricate both front ski pivots at fitting as shown using Polaris All Season grease.
- Grease jackshaft and driveshaft clutch side bearings.
- Use an aerosol lubricant on the steering post support bracket.
- Grease center steering arms.
- Grease steering post lower pivot.

Refer to suspension section of this manual for locations of these components.

NOTE: A grease gun kit complete with grease and adaptors is available to lubricate all fittings on Polaris snowmobiles. Order PN 2871312.

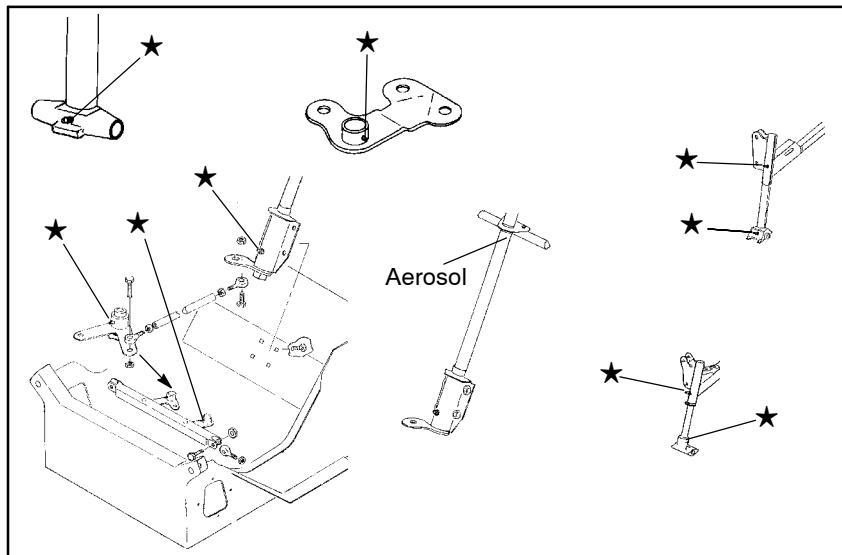

Coupler Greasing - WideTrak

Grease couplers on driveshaft and jackshaft

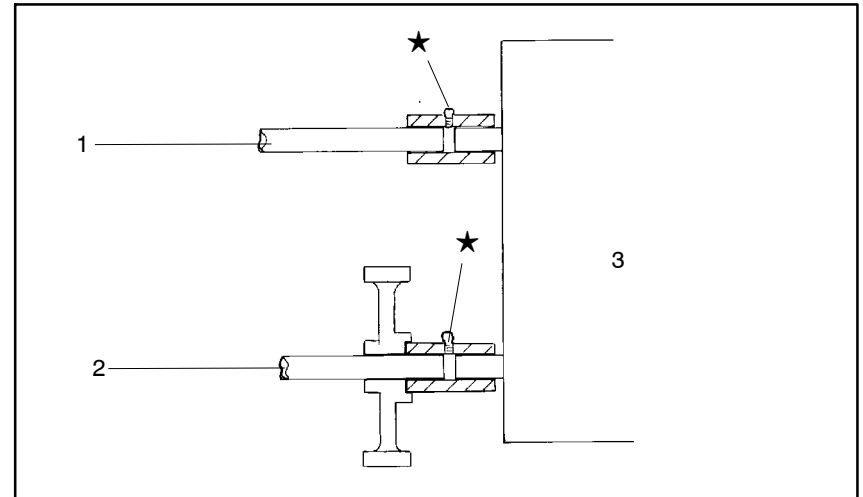

NOTE: Grease points in the illustrations are indicated by a ★.

- 1. Jackshaft
- 2. Driveshaft
- 3. Transmission

Jackshaft Bearing Greasing

Loosen driven clutch retaining bolt and pull clutch outward to expose bearing and grease fitting. Inject grease into grease fitting in flange until grease purges out, inside or outside the bearing seal (this should take only 2 pumps). Push clutch back onto shaft and replace clutch retaining bolt. Torque to 18 ft. lbs. (2.48 kg/m).

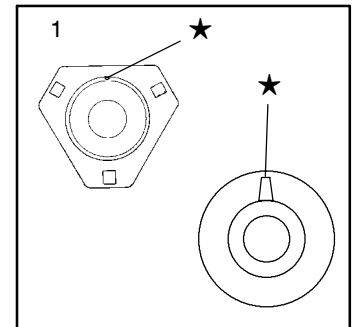

Driveshaft Bearing Greasing

Inject grease into fitting on speedometer drive adaptor until grease purges out inside or outside bearing seal (this should take only 2 pumps).

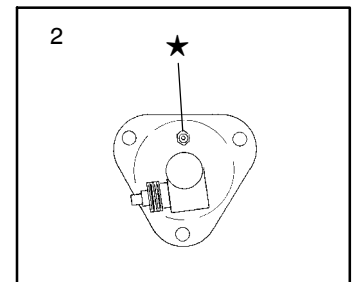

MAINTENANCE

Intake Filter

The intake foam filter limits snow ingestion into the intake system. When operating in loose powder snow, check top of foam filter periodically to remove any accumulation of snow.

CAUTION:

Do not operate machine with the intake filters removed. This can cause carburetor icing resulting in poor fuel economy or carburetor malfunction.

Refer to the next page for the location of the following components. **NOTE:** These are general representations, your model may differ.

1. Intake Foam Filter
2. Air Intake box
3. Air Plenum
4. Dash Cowl

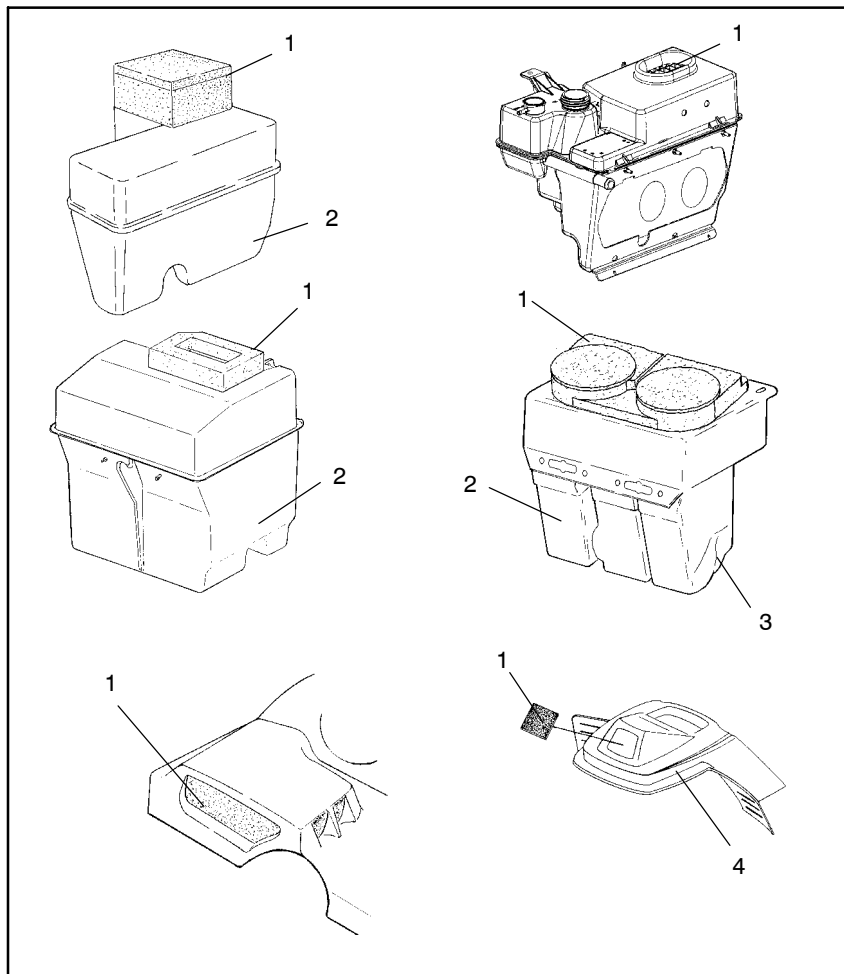

Under Hood Air Intake System

The Indy 340s are equipped with an under hood air intake system which should normally be left open. The door should be closed and latched above 35° F (2° C) for maximum performance during warm weather operation. Simply pull the strap out and up to latch the door and reverse the procedure to open it.

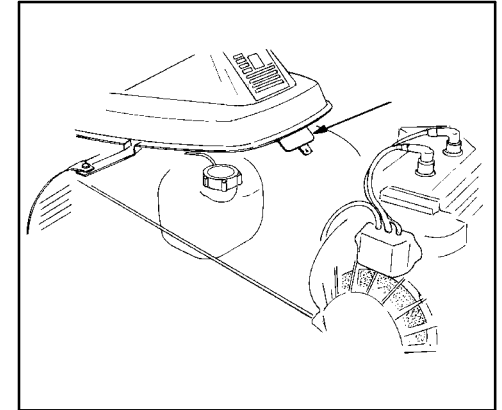

MAINTENANCE

Spark Plug Selection

Original equipment parts or their equivalent should always be used. However, the heat range of spark plugs is of utmost importance. A spark plug with a heat range which is too high will cause engine damage. A spark plug with a heat range which is too low will cause excessive fouling and malfunction.

In selecting a spark plug heat range for production, a manufacturer is forced to assume that the engine is going to operate under extreme heavy duty conditions. This protects the engine from internal damage in the event that the purchaser actually does operate the engine in this manner. This selection however, could cause the customer who normally operates the engine under medium or light duty to have spark plug failure. Refer to your Owner's Manual Supplement for the specific spark plug to be used in your machine.

CAUTION:

A plug with a heat range which is too high will *always* cause engine damage if the engine is operated in conditions more severe than that for which the spark plug was intended.

A new engine can cause temporary spark plug fouling even though the heat range is proper, due to the preservative which has been added during assembly of the engine to combat rust and corrosion. Avoid prolonged idle speeds, as plug fouling and carbonization will result.

- Use recommended spark plugs
- Proper electrode gap is .028"/0.7mm
- Spark plug torque is 18-22 ft. lbs. (2.5-3 kg/m)
- Always carry spare spark plugs in case of an emergency

NOTE: Incorrect fuel mixture can often cause a spark plug to appear to be too dark or too light in color. Before changing spark plug heat ranges, be sure the correct main jet is installed in the carburetor(s).

The spark plug and its condition is indicative of engine operation. The spark plug firing end condition should be read after the engine is warmed up and the vehicle is driven at higher speeds. Immediately check the spark plug for correct color.

Normal

The insulator tip is gray, tan, or light brown. There will be a few combustion deposits. The electrodes are not burned or eroded. This indicates the proper type and heat range for the engine and the service.

NOTE: The tip should not be white. A white insulator tip indicates overheating, caused by use of an improper spark plug or incorrect carburetion adjustments.

Wet Fouled

The insulator tip is black. A damp oily film covers the firing end. There may be a carbon layer over the entire nose. Generally, the electrodes are not worn. General causes are excessive oil, use of non-recommended injection oil, excessive idling, idle too low or too rich, or weak ignition output.

Spark Plug Removal and Replacement

⚠ WARNING

Never attempt to remove the spark plug while the engine is warm. The exhaust system or engine could burn you, causing severe injury.

The spark plug is removed by using the special wrench (1) provided in the tool kit. Remove the spark plug cap. Remove the spark plug by rotating counterclockwise.

Reverse the procedure for spark plug installation. Torque to 18-22 ft. lbs. (2.5-3 kg/m). **NOTE:** Always check the gap on new spark plugs with a wire gauge.

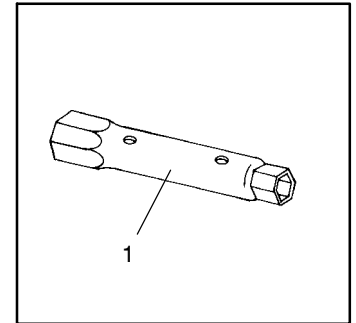

MAINTENANCE

Water Pump Belt Inspection

Some liquid cooled models will require an inspection of the waterpump belt. This belt inspection interval is 1500 miles (2400 km). Inspect belt width and condition as illustrated and replace if cracking or worn past the width service limit (.250" / 6.35mm). If the belt needs to be replaced, see your Polaris dealer.

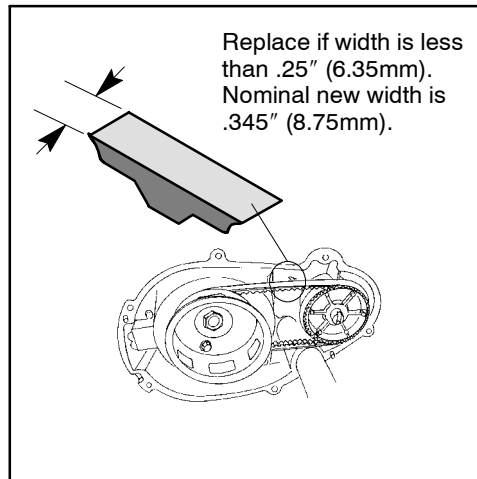

Water/Sediment Trap Service

Most Polaris snowmobiles incorporate patented carburetor bowl water/sediment traps which are located at the bottom of each carburetor. The trap consists of a hose with a plug, which should be inspected for contamination and drained at least every 2000 miles (3200 km).

WARNING

When draining the traps, fuel spillage will occur. Be sure to work in a well ventilated area away from anything which may cause the fuel to ignite such as open flames, sparks, heaters, trouble lights, cigarettes, etc.

Cleaning Procedure - Plug

1. Turn the fuel tank supply valve off.
2. Position a container or shop towels to catch the contaminated gasoline.

 Heed the gasoline warnings found on page 34.

3. Slide the clamp (1) away from the drain plug (2) and remove the drain plug from the sediment tube.
4. Wipe off residue from plug and reinstall with clamps. Continue until all the traps have been emptied.

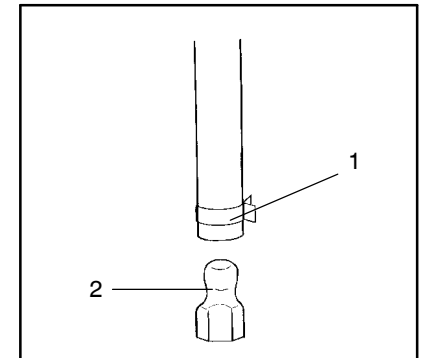

Cleaning Procedure - Nipple

1. Turn the fuel tank supply valve off.
2. Position a container or shop towels to catch the contaminated gasoline.
3. Slide the clamp (1) away from the nipple (3) and remove the nipple. Empty the tube and reinstall. Continue until all the traps have been emptied.

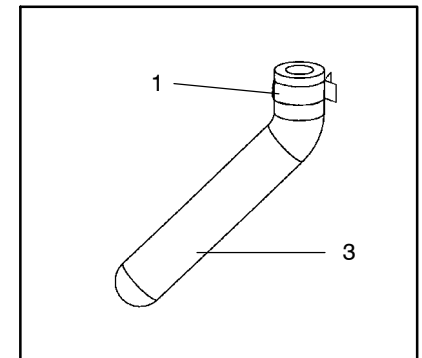

MAINTENANCE

Fuel Filter/Fuel Lines

CAUTION:

The fuel filter (3 - external fuel filter) (4 - in-tank fuel filter) and fuel lines should be inspected regularly. Special attention should be given to the system's fuel line condition after periods of storage. Normal deterioration from weather and fuel compounds can occur.

Oil Filter

The oil filter (5) is of a special design and must not be substituted. This filter should be changed annually or every 1200 miles (1920 km). Inspect oil line condition at 2000 miles (3200 km).

NOTE: The direction of the arrows indicates the direction of the flow through the filters.

NOTE: After changing the oil filter, the oil injection system must be bled of all trapped air. See your dealer for instructions or have your dealer perform the filter change and bleeding operation for you.

The only oil recommended for this system is Polaris brand oil.

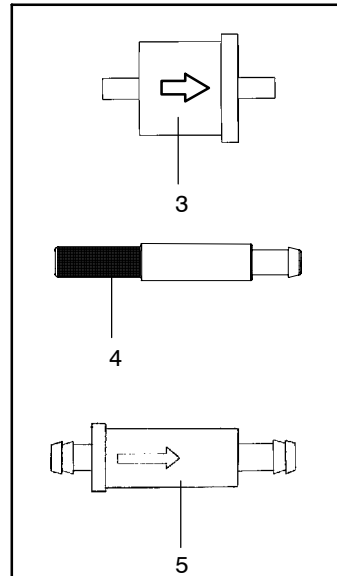

General Carburetor Information

The number size stamped in the end of the main jet indicates the jet size which was installed at the time of manufacture.

The installed main jet is not necessarily correct for your elevation.

It is the Polaris dealer's responsibility to ensure that the correct main jets are installed in each machine for your area of operation.

WARNING

Carburetor adjustments should be performed only by a knowledgeable service technician at a Polaris servicing dealer using the proper tools, procedures and specifications.

Carburetor Adjustments

Proper carburetor adjustments include the following:

- Carburetor component changes for specific altitude and ambient temperatures;
- Choke adjustment and synchronization;
- Air screw settings, if applicable;
- Idle RPM adjustments;
- Equalizing air flow at idle;
- Equalizing air flow at off idle;
- Throttle safety switch checks and servicing;
- Throttle block to throttle flipper clearance adjustment; and
- Oil pump lever and cable adjustment, where applicable.

The frequency at which the carburetors are synchronized or balanced is important. Properly adjusted carburetors can greatly improve engine performance, fuel economy, engine life and reliability.

Improperly adjusted or unsynchronized carburetors can lead to one or more of the following:

- Hard starting.
- Poor idle.
- Overheated pistons and cylinder walls.
- Plug fouling.
- Poor engine response to various throttle valve openings.

MAINTENANCE

ACCS

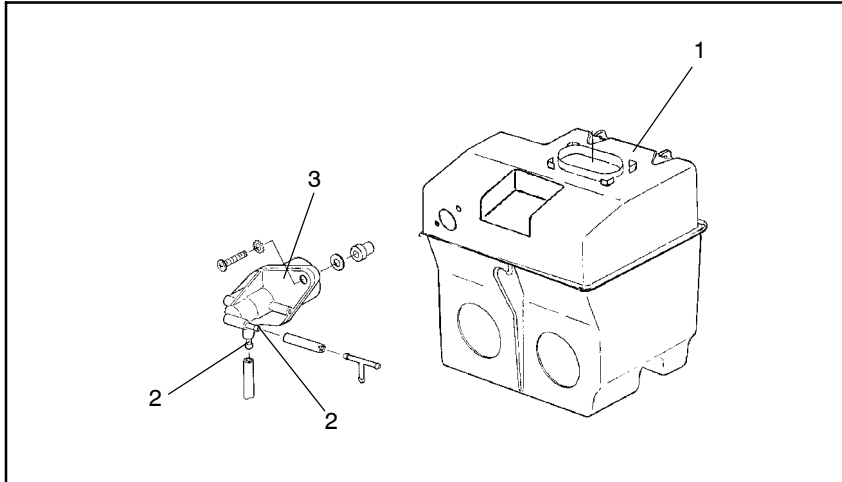

1. Air Box
2. Vent Line Attachment
3. ACCS Valve

Some models are equipped with the Polaris ACCS (Altitude Compensating Carburetor System). The ACCS is designed to compensate automatically for changes in altitude without having to change carburetor jets. See your dealer for ACCS service or adjustment.

Carburetor Protection During Off Season Storage

Whenever the machine is stored for a period of more than 60 days it is highly recommended that the engine be fogged with Polaris PN 2870791. Follow the engine fogging instructions provided on the can. See pages 85-86 for more complete information about storing your machine during the off season.

When preparing your snowmobile for off season storage we recommend that you add a fuel conditioner/stabilizer or Premium Carbon Clean (2871326) to the fuel tank. Follow the instructions on the can. Run the engine for five minutes to get additives through the entire fuel system. Then top off with fresh fuel.

If stabilizer is not used, the carburetors should be drained by removing the water trap drain plugs. Catch fuel in a container or shop cloth. Reinstall plugs securely. Observe all fire safety rules when draining carburetors. See gasoline warnings on page 34.

CAUTION:

Using lower than the recommended octane fuels or operating with obstructed fuel systems will lead to costly engine damage.

Exhaust System

At approximately 2000 miles (3200 km) it is a good idea to check the exhaust system for wear or damage. To inspect, allow engine and exhaust system to cool completely. Open the hood and inspect the muffler and pipes for cracks or damage. Check for weak or missing retaining springs or damper/support grommets.

⚠ WARNING

Exhaust system temperatures can exceed 900° F (500° C). Serious burns may occur if this inspection is performed without allowing adequate time for the exhaust system to cool. Never perform this procedure with the engine running.

MAINTENANCE

Engine Cooling - Liquid Cooled Models

The cooling system on the liquid cooled Indy consists of the following major components: recovery tank, water pump, cylinders, heads, inlet and outlet manifolds, pressure cap and heat exchangers. The heat exchangers are located beneath the running boards and front close-off panel in front of the drive shaft and/or under the seat. Coolant is pumped through the cylinders, heads, and manifolds. The coolant is then pumped through the heat exchangers, where it is cooled as snow comes in contact with the fins on each exchanger. The “cooled down” fluid then returns to the water pump and is re-circulated.

Coolant Mixture

The coolant supplied in the system is a 50-50 mixture of ethylene-glycol and distilled water. This mixture will provide protection against freezing at temperatures down to -34° F (-37° C). If greater protection against freezing is required, the percentage of antifreeze to water may be increased. Use Premium 60/40 anti-freeze coolant. Never exceed a 60% antifreeze, 40% water mixture. Contact your dealer if greater protection is required.

NOTE: Never add tap water to the cooling system. Minerals cause deposits and may react adversely with the metals in the engine and cooling system.

Coolant High Temperature Indicator Light

The high temperature indicator light is controlled by a switch installed into the engine coolant system. If the engine coolant reaches a certain temperature, depending on the model, the switch completes a circuit which turns the light on.

If you must drive the machine back to your starting point, drive slowly and stop frequently to allow normal cool down of the engine. Contact your dealer.

Coolant Level

The engine coolant level is controlled or maintained by the recovery system. The recovery system components are: the coolant tank or overflow tank, engine filler neck, pressure cap (in some models), and connecting hoses.

As coolant operating temperature increases, the expanding excess coolant is forced out of the engine, past the pressure cap (if applicable), and into the overflow tank. As engine coolant temperature decreases, this contracting coolant is drawn back up from the tank, past the pressure cap or filter and check valve, and back into the engine.

CAUTION:

The coolant reservoir or surge tank must be maintained between the minimum and maximum levels to prevent overheating and serious engine damage. Some models, maintain coolant level at the “full cold” line on the coolant tank with the engine cold.

Flushing the Cooling System

To ensure that the coolant maintains its ability to protect the engine, the system should be completely drained every two years and a fresh 50/50 or 60/40 mixture of antifreeze and distilled water should be added. This service must be done when the engine is cold.

Bleeding the Cooling System

▲ WARNING

Never bleed the cooling system when the engine is hot. Severe personal injury could result from steam or hot liquid.

Never remove the pressure cap (1) when the engine is warm or hot. If the pressure cap is to be removed, the engine must be cool.

Use of a non-standard pressure cap will not allow the recovery system to function properly. If the cap should need replacement contact your dealer for the correct replacement part and pressure rating.

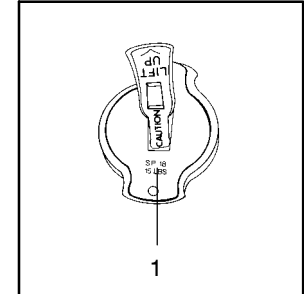

Recovery System Models

If the coolant level becomes low in the recovery tank, the system should be bled of any trapped air using the following procedure:

1. Fill the recovery tank with coolant to the maximum indicated mark.
2. Elevate front end of machine slightly to aid bleeding of the heat exchangers.
3. With pressure cap removed, add coolant and fill to the top of the filler neck.
4. Install the pressure cap with the lever lock up in its release position.
5. Run the engine at slow (600 RPM) for two to three minutes. This will purge the system of trapped air.
6. Close the lever lock and check recovery tank fluid level.

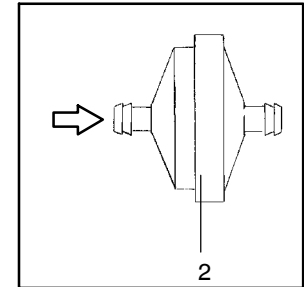

CAUTION:

Most cooling systems are equipped with a filter (2) which should be periodically inspected or replaced. If coolant flow becomes restricted or plugged, coolant loss, air lock or engine damage may result.

MAINTENANCE

Surge Tank Models

1. Remove the pressure cap from the recovery tank and fill with properly mixed coolant to the maximum indicated mark.
2. Elevate front end of machine slightly to aid bleeding of the heat exchangers.
3. Remove the bleed screw from the water outlet manifold and/or the thermostat housing. Allow the coolant to bleed through the system until it runs out the bleed holes. Reinstall the bleed screw into the manifold.
4. Fill the recovery tank back to the maximum indicated mark.
5. Start the engine and run at a fast idle for two to three minutes. Occasionally loosen the bleed screw to purge any trapped air in the system.
6. Shut off engine and check the recovery tank level. Fill as required.
7. Feel the heat exchangers under the running boards. If the system is bled properly, they will be warm to the touch. If they are not, repeat step four and lift the front of the machine slightly to assist in the bleeding.

Throttle Cable Lubrication

With the engine off, lubricate the throttle cable occasionally with Polaris Cable Lubricant (PN 2870510). Turn the handlebars to the left and lubricate liberally as shown.

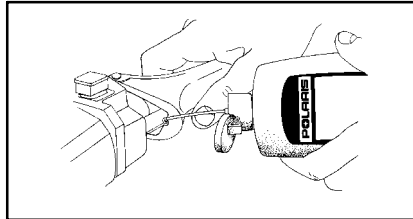

Choke and Cable Lubrication

Lubricate the choke slide and cables occasionally as shown with Polaris Cable Lubricant (PN 2870510). Operate the choke intermittently before turning the machine off. This draws moisture out of the choke plunger area and reduces the possibility of the choke becoming frozen.

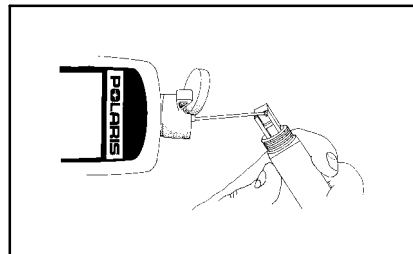

Chaincase Oil Level

The drive chain is continuously immersed in oil. Proper oil level is determined by checking the level on the dipstick (C) with machine placed on a level surface. The oil level should be between the "safe" marks on the dipstick. Add oil through dipstick opening to maintain proper level. Use Polaris chaincase oil (PN 2871280). *Do not overfill.*

NOTE: Clean the magnetic plug (D) every 500 miles (800 km) and whenever checking or changing lubricant.

CAUTION:

Do not mix or use other types of lubricant. Excessive wear to chain, sprockets and bearings will result.

It is the owner's responsibility to maintain proper lubrication of the chaincase.

Drive Chain Tension

To obtain correct chain tension:

1. Rotate driven clutch counterclockwise to move all chain slack to the tensioner side. Lock the brake lever lock or have an assistant hold the brake lever firmly.
2. Loosen the adjuster bolt jam nut (A).
3. Finger tighten the adjuster bolt (B) until it can no longer be adjusted by hand.
4. Back off the adjuster bolt by 1/4 turn.
5. Tighten the jam nut while holding the adjuster bolt.
6. The chain is now tensioned. Release the brake lever lock.

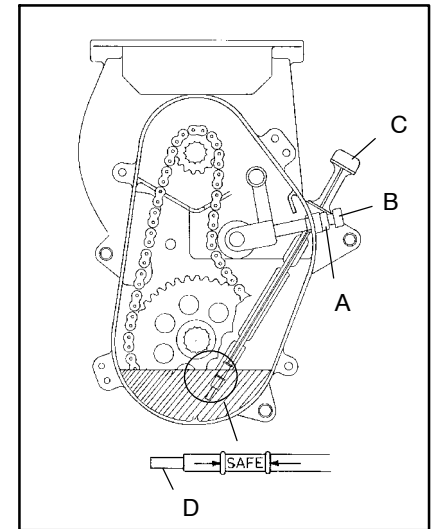

MAINTENANCE

Gearcase Oil Level (WideTrak Models)

Using Polaris Chaincase Oil (PN 2871281), maintain the proper oil level. Proper oil level is determined by checking the level on the dipstick (A) with machine placed on a level surface. The oil level should be between the "safe" marks on the dipstick. Add oil through dipstick opening to maintain proper level. *Do not overfill.*

NOTE: Clean the magnetic plug (B) every 500 miles (800 km) and whenever checking or changing lubricant.

CAUTION:

Do not mix or use other types of lubricant. Excessive wear to chain, sprockets and bearings will result.

It is the owner's responsibility to maintain proper lubrication of the gearcase.

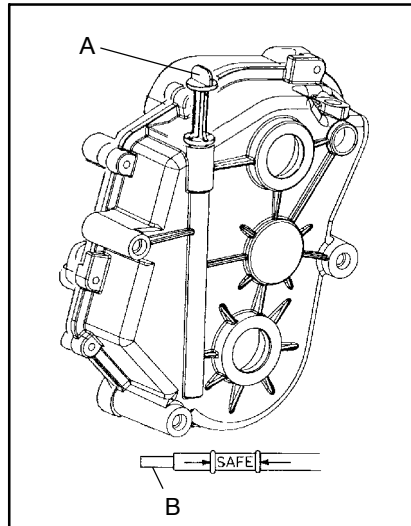

Brake Inspection

The brake lever reserve should be inspected frequently. Measure the clearance between the lever and handlebar grip. Inspection should be made with the lever firmly depressed. Lever reserve (A) should be no less than 1/2" (1.3 cm).

Replacement of brake pads will be necessary when the brake pad material is thinner than the backing plate approximately (1/16"). A kit is available for replacing brake pads. See your dealer.

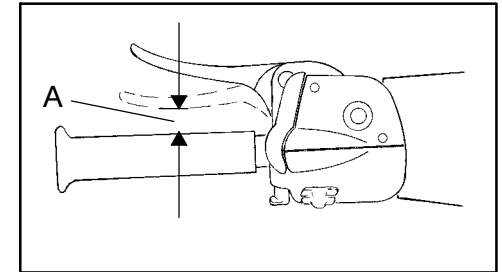

1. Brake Caliper
2. Chaincase
3. Brake Disc
4. Backing Plate
5. Brake Pad Material (Replace when thickness is less than 1/16").

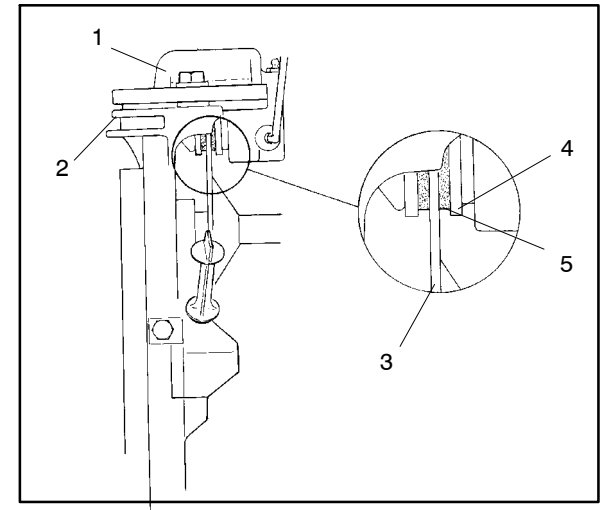

Excessive Lever Travel

The snowmobile's hydraulic brakes are self-adjusting. If excessive brake pad clearance should develop, the machine should be returned to an authorized Polaris dealer for inspection and adjustment.

MAINTENANCE

Replenishing Brake Fluid

CAUTION:

Brake fluid is a hazardous material. Contact with decals, paint, and many plastics will cause damage. Use proper precautions when handling brake fluid.

Remove brake fluid master cylinder reservoir cover. Add Polaris brake fluid (PN 2870990) as required to bring the level up to the top of the fluid level mark on the inside of the reservoir. The proper fluid level is 1/4-5/16" (.6-.8 cm) below the lip of the reservoir opening on most models.

NOTE: On some models, the brake fluid level can be seen through a plastic sight glass in the brake reservoir. If the fluid is sufficient, the sightglass will be black. If the sight glass is any color other than black, you will need to add brake fluid.

On all models, frequently check the reservoir to be sure it contains the correct amount of fluid.

Use only Polaris DOT 3 high temperature brake fluid (PN 2870990). Polaris brake fluid is sold in 12 oz. bottles.

WARNING

Do not over fill the master cylinder. Fluid expansion could cause brakes to lock, resulting in serious injury or death. Once a bottle of brake fluid is opened, use what is necessary and discard the rest. Do not store or use a partial bottle of brake fluid. Brake fluid is hygroscopic, meaning it rapidly absorbs moisture from the air. This causes the boiling temperature of the brake fluid to drop, leading to early brake fade and the possibility of serious injury.

Dirt and debris should be kept off the master cylinder cover. The cover has vent slits to allow for diaphragm movement. If these vents become plugged, movement of brake fluid below the diaphragm may be restricted, altering brake function.

Bleeding the Hydraulic Brake System

Air in the hydraulic brake system will cause a springy or spongy brake lever action. Bleeding is necessary to remove air from the system. Refer to illustration on page 69.

1. Remove brake fluid master cylinder reservoir cover and gasket.

CAUTION:

Brake fluid is a hazardous material. Contact with decals, paint, and many plastics will cause damage. Use proper precautions when handling brake fluid.

2. Fill the master cylinder reservoir (B) and replace gasket and cover. Keep the fluid level 1/4-5/16" (.6-.8 cm) below lip of reservoir opening.
3. Fill the master cylinder reservoir (B) and replace gasket and cover. Keep the fluid level between the max and min marks on the side of the reservoir.

▲ WARNING

Do not over fill the master cylinder. Fluid expansion could cause brakes to lock, resulting in serious injury or death.

4. Slip a rubber tube over the ball of the bleeder valve and direct the flow of fluid into an approved container.

▲ WARNING

Never re-use brake fluid. Brake fluid is hygroscopic, meaning it rapidly absorbs moisture from the air. This causes the boiling temperature of the brake fluid to drop, leading to early brake fade and the possibility of serious injury.

5. Squeeze brake lever a full stroke. Then unscrew bleeder valve 3/4 of a turn to release air.
6. Close bleeder valve and release brake lever.

Repeat steps 4 and 5 until fluid flows from bleeder valve in a solid stream free of air bubbles.

7. Re-fill reservoir to proper level after bleeding operation. See Replenishing Brake Fluid on page 70. *Do not overfill the master cylinder.*
8. Replace gasket and cover.

During the bleeding procedure make sure to keep the brake handle in as level a position as possible. The hydraulic fluid reservoir must be in this position to minimize the possibility of air entering the system through the reservoir vent.

▲ WARNING

Excessive or repetitive use of brakes for high speed stops will cause an overheated brake system. This overheated condition could cause sudden loss of brakes and/or fire, resulting in severe injury or death.

When traveling in long downhill stretches remember to use a pumping brake action. Riding the brakes can cause the brake system to overheat, resulting in brake failure.

MAINTENANCE

Brake Adjustment - Mechanical Brakes

If excessive brake lever to brake block clearance is evident, the brake cable or caliper should be adjusted using the following methods. When adjusting calipers, adjust caliper adjuster bolt only. *Do not* adjust cable or cable sleeve length.

WARNING

Improper brake adjustment could result in brake failure which could result in severe injury or death.

Cable Adjustment

1. Make sure floating parts move freely and all parts are mounted securely. Tighten hardware as required.
2. Check actuator linkage to ensure there is adequate freedom of movement for positive brake operation.
3. Loosen lock nuts (A).
4. To increase brake lever free play, turn nuts counterclockwise to move cable (B) down in bracket. To decrease lever free play move cable up in bracket. Tighten lock nuts.
5. If cable adjuster has reached maximum, the lever arm can be re-indexed twice before brakepads require replacement. When pads are replaced, brake lever arm must be re-indexed to obtain proper freeplay. Brake lever free play should be $1/4 - 3/8''$ (6-10 mm).
6. Loosen lock nuts and turn counterclockwise (as viewed from the top) to obtain the maximum amount of cable freeplay. Straighten tab on tab washer and loosen bolt enough to disengage actuator lever spline.

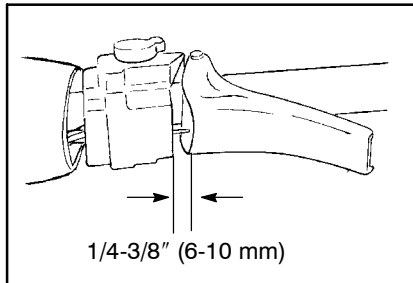
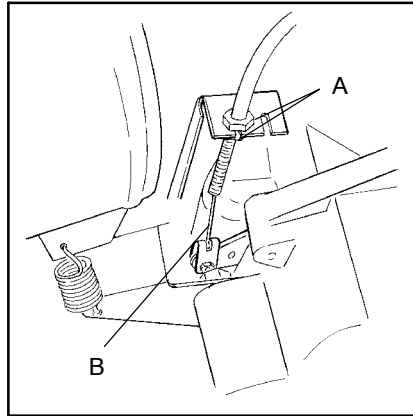

Cable Adjustment (Cont.)

7. Slip long leg of lever spring (D) off caliper and rotate to the side.
8. Rotate lever (E) one tooth in the direction opposite the actuation direction and tighten bolt. Make sure spline teeth are properly engaged.
9. Bend up a tab (C) aligning with one of the bolt head flats to prevent bolt rotation.
10. Return the spring to its original position on the caliper. Both lever and linkage must be free to return to original position.
11. Perform steps 3. and 4. to adjust lever freeplay.
12. Verify proper brake operation. Disc should rotate freely without drag.
13. Check disc surface condition.

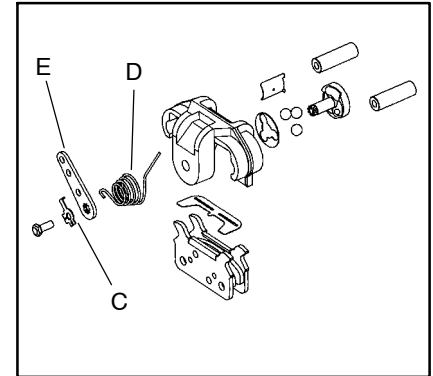

Mechanical Brakes

Brake Lever Travel

Measure the clearance between the lever and brake block. Inspection should be made with the lever firmly depressed. Distance B should be no more than 3/4" (1.9 cm).

Excessive travel indicates a need to adjust the brake cable adjuster. Refer to the mechanical brake adjustment information on page 72.

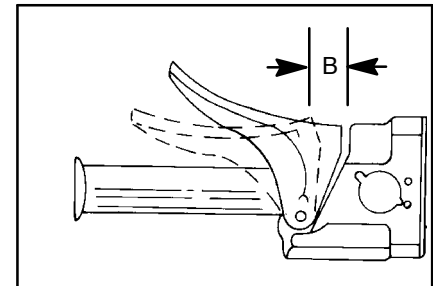

MAINTENANCE

Brake Inspection

⚠ WARNING

Be certain brake pads do not drag on disc and brake lever travel is not excessive.

Replacement of brake pads will be necessary when the brake pad material is thinner than the backing plate approximately (1/16"). A kit is available for replacing brake pads. See your dealer.

1. Brake Caliper
2. Chaincase
3. Brake Disc
4. Backing Plate
5. Brake Pad Material (Replace when thickness is less than 1/16").

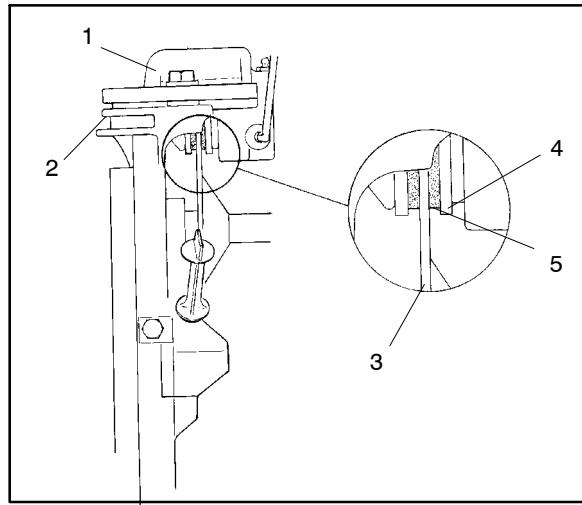

Headlight Adjustment

The headlight can be adjusted for vertical aim using the following procedure:

1. Place snowmobile on a level surface with headlight approximately 25' (7.6m) from a wall.
2. Measure distance from floor to center of headlight and make a mark on the wall.
3. Start engine and turn headlight switch to high beam.
4. Observe headlight aim. The most intense part of the headlight beam should be aimed 2" (5.1 cm) below the mark placed on the wall in Step 2.
NOTE: Rider weight must be included on the seat.
5. On evolved models, turn the adjustment knob (B) located inside the hood just below the headlamp opening. Turn knob in or out as needed for proper aim. On aggressive models, insert a Phillips screwdriver into the access hole (C) on the top of the instrument housing and turning the screw until correct adjustment is achieved.

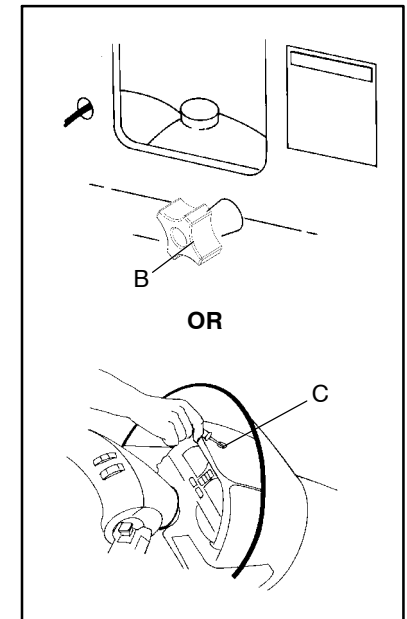
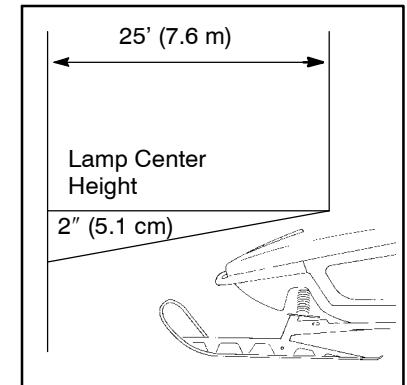

MAINTENANCE

NOTE: Do not touch a halogen bulb with bare fingers. Oil from skin leaves a residue, causing a hot spot which will shorten the life of the lamp.

Removing Halogen Bulbs - Low Beam

1. Pinch ends of the spring (1) together and lift until it releases from the spring retainer.
2. Lift spring carefully around wire harness (2) and flip to outside of housing.
3. With the wire harness attached to the bulb (3), withdraw bulb from housing.
4. Grasp bulb by metal base and carefully separate bulb from harness.

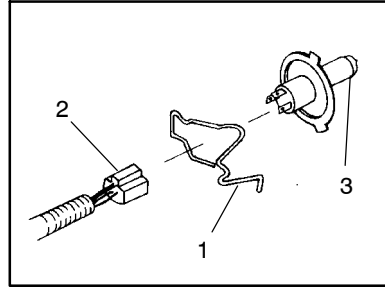

Installing the Bulb

1. Hold bulb by metal base and install into wire harness.
2. Insert bulb into housing.
3. Carefully flip spring back into housing placing it around wire harness.
4. Squeeze spring together until it is over the spring retainer and release.
5. Verify headlight aim.

Removing Halogen Bulbs - High Beam

1. Remove the wire harness
2. Grasp the bulb firmly and twist it 1/2 turn counterclockwise.

NOTE: Do not touch a halogen bulb with bare fingers. Oil from skin leaves a residue, causing a hot spot which will shorten the life of the lamp.

3. Remove the bulb from housing and replace with new bulb.
4. Place the bulb and housing back inside the hole and turn the housing 1/2 turn clockwise to lock into place.
5. Reinstall the wire harness to the housing.

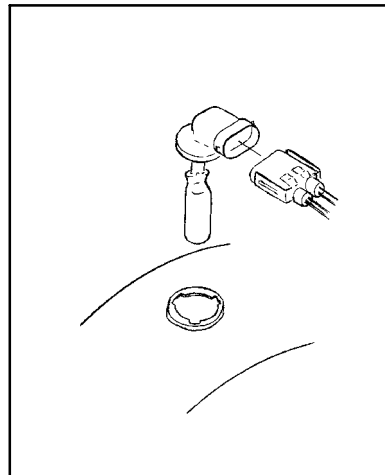

MAINTENANCE

NOTE: Do not touch a halogen bulb with bare fingers. Oil from skin leaves a residue, causing a hot spot which will shorten the life of the lamp.

Removing the Side Bulbs

1. Disconnect terminal from back of bulb.
2. Turn bulb assembly 1/4 turn to right and withdraw from housing.

Installing the Side Bulbs

1. Hold bulb assembly by plastic base and plug into wire terminal.
2. Insert bulb assembly into housing.
3. Turn bulb assembly 1/4 turn to left to secure in housing.
4. Verify headlight operation.

Wrap Around Taillight Bulb Replacement

1. Remove Phillips screws from taillight lens (A).
2. Working from front to back, carefully pry lens away from seal and remove lens.
3. Pull bulb(s) (B) straight out from socket and insert new bulb.
4. Reinstall lens.

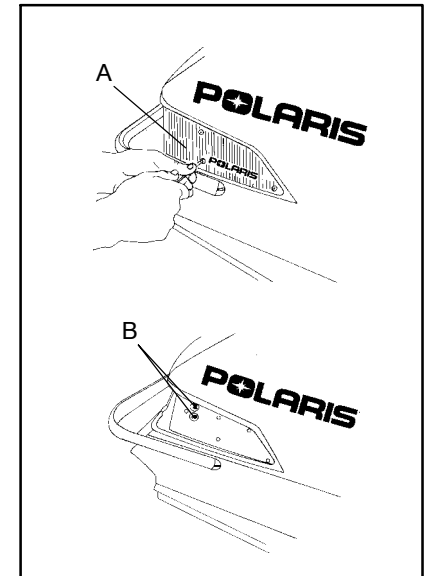

MAINTENANCE

Handlebar Adjustment - All Other Models

Your snowmobile has handlebars which may be adjusted for your personal fit.

1. Remove handlebar cover and foam.

2. Using a 7/16" (11 mm) wrench, loosen four nuts on bottom of adjuster block. **NOTE:** Turn handlebar to left or right for access to back nuts.

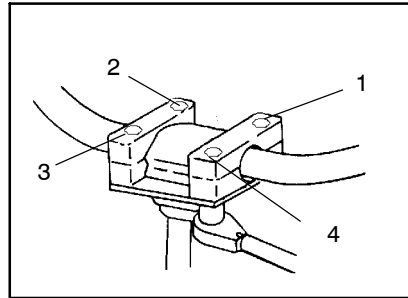

3. Adjust handlebar to the desired height. Be sure that handlebars, brake lever and throttle lever operate smoothly and do not hit the gas tank, windshield or any other part of the machine when turned fully to the left or right.

4. Torque the handlebar adjuster block bolts to 11-13 ft. lbs. (1.5-1.8 kg/m).

5. Replace handlebar cover and foam.

Backrest Adjustment

The passenger backrest on some models is adjustable. To move the backrest forward or backward, lift the adjustment lever on the left side (A).

To lengthen or shorten the backrest cable, lift the cable until spring tension is felt and lock the jamb nut.

When adjusting the backrest from a passenger position to a single rider position, rotate the backrest cushion adjustment knobs (B) until the proper angle is reached.

The grab bars have five height adjustments. To raise or lower the grab bar, remove the grab bar adjuster knob (C), position the grab bar at the desired height, and reinstall the knob.

Some models are also equipped with passenger handwarmers. The switch (D), located under the left hand wind deflector, has three settings: High, Off, and Low.

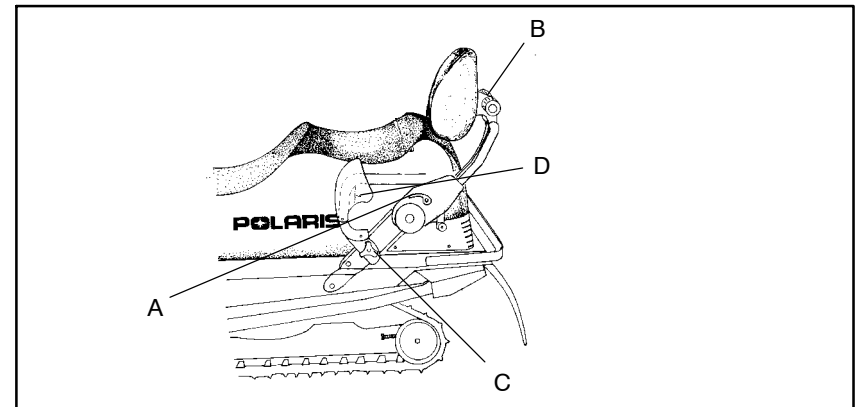

MAINTENANCE

Drive Belt

WARNING

Periodically check the condition and tension of the drive belt. Always carry a spare belt. Inspect clutch sheaves for damage, wear, or belt residue. Clean with non-oil base cleaner such as isopropyl alcohol.

To ensure satisfactory belt life, install belts so they operate in the same direction of rotation. Position the identification numbers so that you can read them. This will keep the belt rotating in the same direction.

For improved drive away during extreme cold temperatures, remove the belt and warm it up to room temperature. Reinstall it before starting the vehicle.

Belt Removal - A

1. Be sure key switch is off and engine has come to a complete stop. Remove the retaining knob or pin and open the clutch guard.
2. Apply brake (or lock parking brake if so equipped).
3. Grasp belt firmly midway between clutches and pull upward and rearward. Remove the belt.

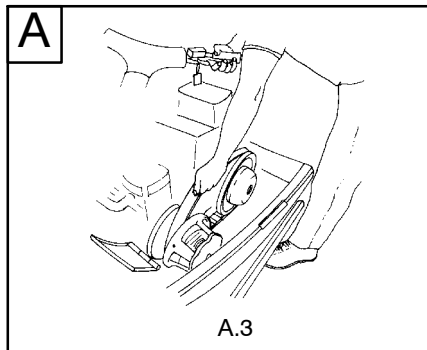

Belt Installation - B

1. Drop the drive belt over the drive clutch and pull back the slack. Numbers should be readable from right side of unit.
2. Turn the driven clutch moveable sheave clockwise while at the same time pushing inward and forcing the belt down between the sheaves.
3. Hold the belt down between the sheaves and roll the bottom portion over the outer clutch sheave. Once installed, be sure to work the belt to the outer edge of the sheave. Be sure to release parking brake if applied.
4. Close the clutch guard and reinstall the retaining knob or pin.

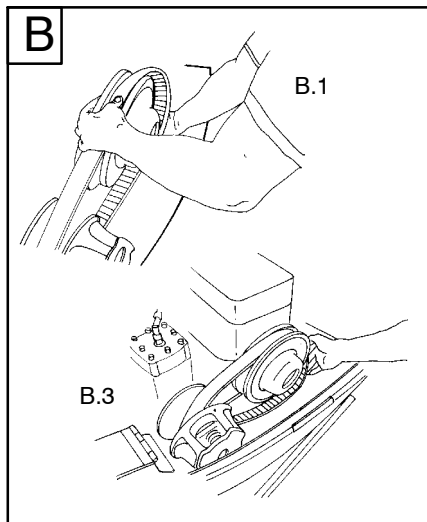

Clutch System

Do not lubricate clutch bushings. The bushings in the weights and rollers of Polaris clutches are made of a material which may be damaged if lubricated. Clean clutch sheaves periodically to maintain optimum performance.

WARNING

All clutch maintenance and repairs must be performed by an authorized Polaris servicing dealer. Any unauthorized modifications to clutches, such as adding or removing weights, will void the warranty.

If you become aware of higher than normal engagement, an unusual vibration, or an unusual shift pattern, contact your dealer immediately. Do not operate the machine until corrections have been made.

Clutch Alignment and Offset

The primary drive belt is a very important part of the drive train. Proper adjustment of the two clutches (torque converter assembly) is necessary to obtain proper belt life. The information on this page is most important in maintaining proper tolerances. If you desire more information, consult your dealer.

The recommended offset between the drive and driven clutches with the belt removed is found on the Owner's Manual Specification Supplement.

Clutch center distance and alignment are crucial in maintaining optimum performance. The drive belt is a very important part of the drive system. Belt to sheave clearance in the drive clutch should be kept at a minimum. With a new belt, the least amount of clearance will provide the best throttle response. See your dealer for adjustments. Belt width and length must match the center distance of the clutches and sheave width of the drive clutch. For this reason, Polaris recommends that only O.E.M. belts be used. Other belts may match the dimensions, but can drastically change the shift pattern, resulting in poor performance characteristics.

NOTE: A worn belt will continue to function, but will not deliver maximum performance. Always carry a spare belt in case of an emergency. Belt removal and installation are covered on page 80.

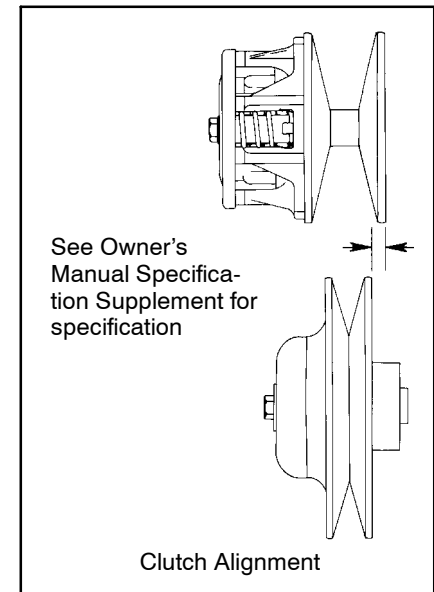

MAINTENANCE

Clutch Center Distance

Measure belt deflection with both clutches at rest and in their full neutral position.

Place a straight edge on the belt and apply downward pressure while measuring at the point shown.

The recommended center distance for your machine can be found on the Owner's Manual Specification Supplement.

Due to tolerances in belt length, it may be necessary for your dealer to make minor adjustments in the driven clutch to achieve correct belt tension.

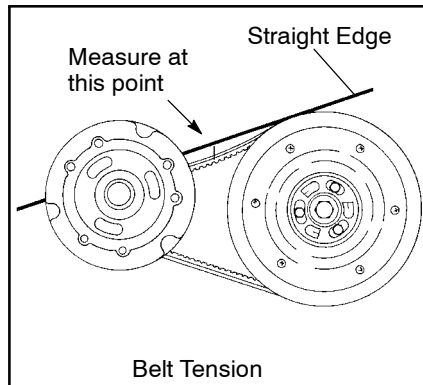

Belt Deflection Adjustment (P-85 System)

Adjustment can be done on P-85 clutches without removing the clutch from the jackshaft.

1. Pull belt into driven clutch to slightly open sheaves.
2. Loosen the three bolts on the adjustment cam.
3. To reduce distance between sheaves, turn cam counterclockwise. Torque bolts to 10 ft. lbs. (1.4 kg/m)

NOTE: If your model has a P-90 clutch, any adjustments must be performed by your dealer.

Torque Stop

If your machine is equipped with a torque stop, periodically check torque stop clearance. Before this procedure it will be necessary to ensure the clutches are properly aligned. The torque stop clearance should be a minimum of .010" to a maximum of .030" from the engine case. Adjust if necessary and lock jam nut.

Reverse Kit Maintenance

If your machine is equipped with reverse or if you have a reverse kit installed, it is especially important to maintain track tension as specified on page 89.

WARNING

If specified track tension is not maintained severe damage to the machine may occur, which can result in loss of vehicle control. Loss of control can result in severe personal injury or death.

- Never attempt to shift into reverse while machine is moving.
- Allow engine to reach idle speed before attempting to shift into or out of reverse.

CAUTION:

If machine has not come to a complete stop before shifting, damage will occur to chaincase or transmission.

If you have had a reverse kit installed on your snowmobile, some maintenance will be required. Follow these recommendations:

Chain Tension

Maintain the proper chain tension. See page 67.

Oil Level

Maintain the oil level between the safe marks on the dipstick.

Oil Change

Change the oil annually.

MAINTENANCE

Reverse Operation

 **WARNING**

This snowmobile is capable of excessive reverse speed! Reverse operation can be dangerous even at moderate speeds. Steering control becomes difficult in reverse. Misuse of reverse can result in serious injury or death.

The transmission may not always be in the gear indicated by the shift lever. Apply the throttle slowly until the correct gear is assured.

Make sure the shift lever is shifted completely into forward or reverse position. Do not force the shift lever into reverse if resistance is felt.

The gears may not always be aligned for shifting into reverse. Forcing the lever may cause the cable to bend. If resistance is felt, apply the throttle to move the gears to a different position and try to shift again.

Sometimes the drive belt will drag in the drive clutch causing slight tension in the transmission, making it hard to shift. Shutting the engine off will remove this tension and ease shifting. This should only happen during the break in of a new belt or if the drive/driven clutch center distance is too long. If this is the case, belt tension adjustments should be made by your dealer.

Extended Storage

Off season or extended storage of your snowmobile requires you to take preventative measures to aid against deterioration and to prolong the useful life of many components.

Cleaning and Preservation of Hood, Chassis, and Trim

Proper storage starts by cleaning, washing, and waxing the hood, chassis, upholstery, and plastic parts. Clean and touch up with paint any rusted or bare metal surfaces. Be sure that corrosive salt and acids are removed from surfaces before beginning preservation with waxes and rust inhibitors (grease, oil or paint).

The machine should be stored in a dry garage or shed out of direct sunlight and covered with a fabric snowmobile cover. Plastic tarp can cause condensation to form and damage some snowmobile components.

Controls and Linkage

All bushings, spindle shafts, and tie rod ends should be coated with a light coat of oil or grease. Throttle controls and cables should be lubricated with Polaris cable lubricant (PN 2870510). Force a small amount of lubricant down the cable.

Bearings

To prevent corrosion which will destroy the bearings, always grease jackshaft and drive shaft clutch side bearings with a high quality bearing grease. See page 52.

Electrical Connections

Separate electrical connector blocks and clean corrosive build up from connectors. Lubricate or pack connector blocks with dielectric grease (PN 2871044) and re-connect. Replace worn or frayed electrical wire and connectors. Be sure wiring harness is properly secured away from sharp edges, steering linkage, moving parts, and hot exhaust.

Clutch and Drive System

Remove drive belt and store in cool dry location. Lubricate sheave faces of drive and driven clutches with a light coat of oil or Polaris Cable Lubricant (PN 2870510). Do not lubricate clutch components except driven clutch shaft bushing as outlined in Snow Repair Manual.

Battery

Battery must be prepared and maintained as outlined on page 45.

Front Suspension

To minimize fatigue on the front shocks and springs, it is recommended that the front end of the machine be safely blocked off the ground, removing tension from the shocks and springs.

MAINTENANCE

Engine and Carburetor

Proper off season preparation of the engine and fuel system is vital to the prevention of rust and corrosion formation on precision engine parts during storage.

Without proper storage, jet restriction can cause lean conditions and very poor slow speed driving quality.

- When preparing your snowmobile for off-season storage we recommend that you add fuel conditioner/stabilizer or Premium Carbon Clean (PN 2871326) to the fuel tank. Follow the instructions on the can. Run the engine for five minutes to get additives through the entire fuel system. Then top off the tank with fresh fuel.
- Fog the engine with Polaris Fogging Oil (PN 2870791). This is available from your Polaris dealer. Follow the recommended procedures indicated on the can.
- If stabilizer is not used the carburetors should be drained by removing the drain plugs or nipples. Refer to page 59 for procedure. Catch fuel in a container or shop cloth. Reinstall and tighten drain plugs securely. Observe all fire safety rules when draining carburetors. See gasoline warning on page 34.

Engine and Carburetor

Using a fuel stabilizer and topping off the fuel tank eliminates the need to drain the fuel system. If you prefer to drain the fuel tank, use the following procedure:

1. Transfer unused fuel from the fuel tank to an approved fuel container using a siphon pump. Do not re-use fuel after storage.
2. Securely support the front of the snowmobile with a jack stand so the engine is tilted rearward.
3. Remove the spark plug(s).
4. Rotate the engine slowly, watching the piston until it is at BDC - lowest position in the cylinder. On twin cylinder models the opposite piston will be up.
5. Pour approximately two ounces of Polaris injector oil into the spark plug hole.
6. Wait one to two minutes and perform steps 4-6. on remaining cylinders.
7. Replace the spark plugs and set machine on floor

NOTE: This procedure is performed best when the front of the machine is elevated and the engine is tilted rearward.

Track and Suspension

Under normal conditions moderate track tension should be maintained during summer storage. The rear of the machine should be supported off the ground to allow free hanging of the track.

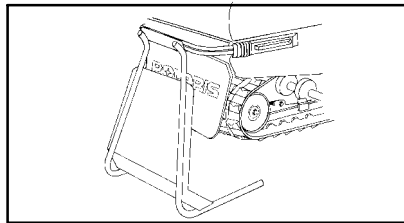

HINT: For easier starting after extended storage, add Polaris Premium 2 cycle lubricant to the fuel in the tank at a 40:1 ratio and run the engine for three to five minutes before storage. This will lubricate the fuel pump diaphragm to keep it flexible and help prevent loss of prime.

Transporting the Snowmobile

Whenever the snowmobile is transported the following measures should be taken:

1. Turn the fuel valve to "Off".
2. Be certain the fuel cap and oil cap are installed correctly.
3. Always tie the snowmobile to the transporting unit securely using suitable straps.

MAINTENANCE

Fall Tune Up

To obtain maximum performance and use from your snowmobile, we encourage you to arrange for a fall service tune-up with your Polaris dealer. He has an experienced and trained service technician who is interested in keeping your machine in peak operating condition.

Towing

If a situation arises requiring the snowmobile to be towed by another snowmobile, attach the tow rope to the spindles, not the ski loops.

WARNING

Always remove the drive belt from a disabled snowmobile before towing to prevent serious damage to the engine and drive system.

Tool Kit

To help you perform emergency and routine maintenance, a tool kit is included with your machine. Items included in the kit are:

- Tubular Socket
- Phillips Screwdriver
- Emergency Start Strap
- Tubular Socket Handle
- Wrench
- Shielded screwdriver (only with models that have indy select or AFX shocks)

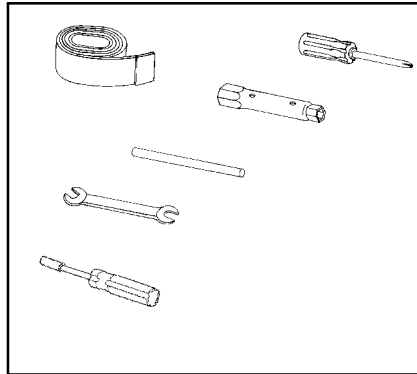

Remember, always keep tools with the machine.

NOTE: Other tools are also necessary to perform maintenance work. They are called out throughout this manual.

If necessary a replacement tool kit may be purchased from your Polaris dealer. Ask for PN 3083227.

For Your Protection

For your added protection it is a good idea to carry the following items with your snowmobile at all times:

- Spare Drive Belt
- Tow Rope
- Fuel Deicer
- Trail Map
- First Aid Kit
- Extra Set of Spark Plugs
- Extra Oil
- Winter Survival Kit
- Owner's Manual

MAINTENANCE

Track Tension Data

Suspension (Refer to Specification Supplement for type)	Weight	Measurement Location	Measurement
XTRA 12 121"	none	2" behind rail bumper	1/2" (1.27 cm) free hanging
XTRA 12 133"	none	16" ahead of rear idler shaft	1-1 1/8" (2.54 - 2.86 cm) free hanging
XTRA 10 121" and 133"	10 lbs. (4.54 kg)	16" ahead of rear idler shaft	3/8 - 1/2" (1 - 1.3 cm)
WideTrak Type	10 lbs. (4.54 kg)	16" ahead of rear idler shaft	3/4 - 1" (1.9 - 2.5 cm)
XTRA Lite 121", 133" and 136"	10 lbs. (4.54 kg)	16" ahead of rear idler shaft	3/8 - 1/2" (1 - 1.3 cm)
XL 136"	10 lbs. (4.54 kg)	16" ahead of rear idler shaft	3/8 - 1/2" (1 - 1.3 cm)

WARNING

When performing the checks and adjustments recommended on the following pages, stay clear of all moving parts to avoid serious personal injury. Do not perform track measurement or adjustments with engine running.

MAINTENANCE

Track Tension

Track adjustment is critical for proper handling. Always maintain correct tension and alignment.

Tension adjustments should be made only after the track is warmed up and limber.

1. Turn the machine off.
2. Lift the rear of the machine and safely support it off the ground.
3. Place the recommended weight or downward pressure on the track at the specified distance (see chart) ahead of the center of the rear idler wheel.

NOTE: Measure at the point where the weight is hanging.

4. Check for specified slack between the wear surface of the track clip and the plastic hi-fax (C).

If the track needs adjustment:

5. Loosen rear idler shaft bolt (D).
6. Loosen locknuts (A) (except on models with Xtra Lite suspension).
7. Tighten or loosen the track adjusting screws (B) as necessary to provide equal adjustment on both sides of the track.
8. Repeat measurement on the other side of the track. **NOTE:** Check more frequently when machine is new.
9. Start machine and slowly rotate the track at least five revolutions, let the track stop rotating by itself (do not apply brakes).
10. Check track alignment (side to side) by comparing the distance from the guide clip to Hi-fax on both sides. Readjust until centered.
11. Tighten Locknuts (A)
12. Tighten Idler Shaft Bolt (D)

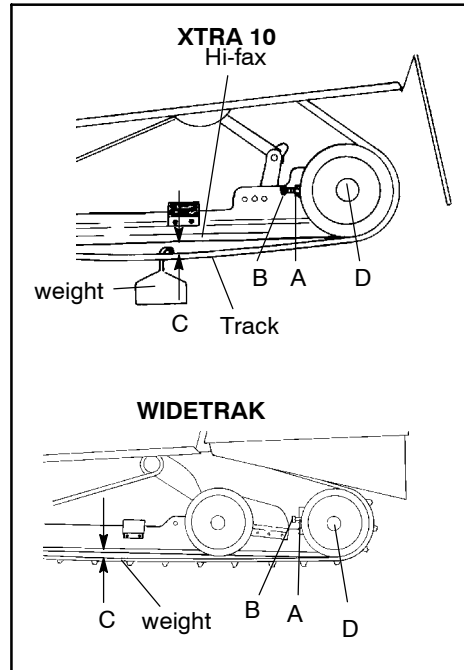

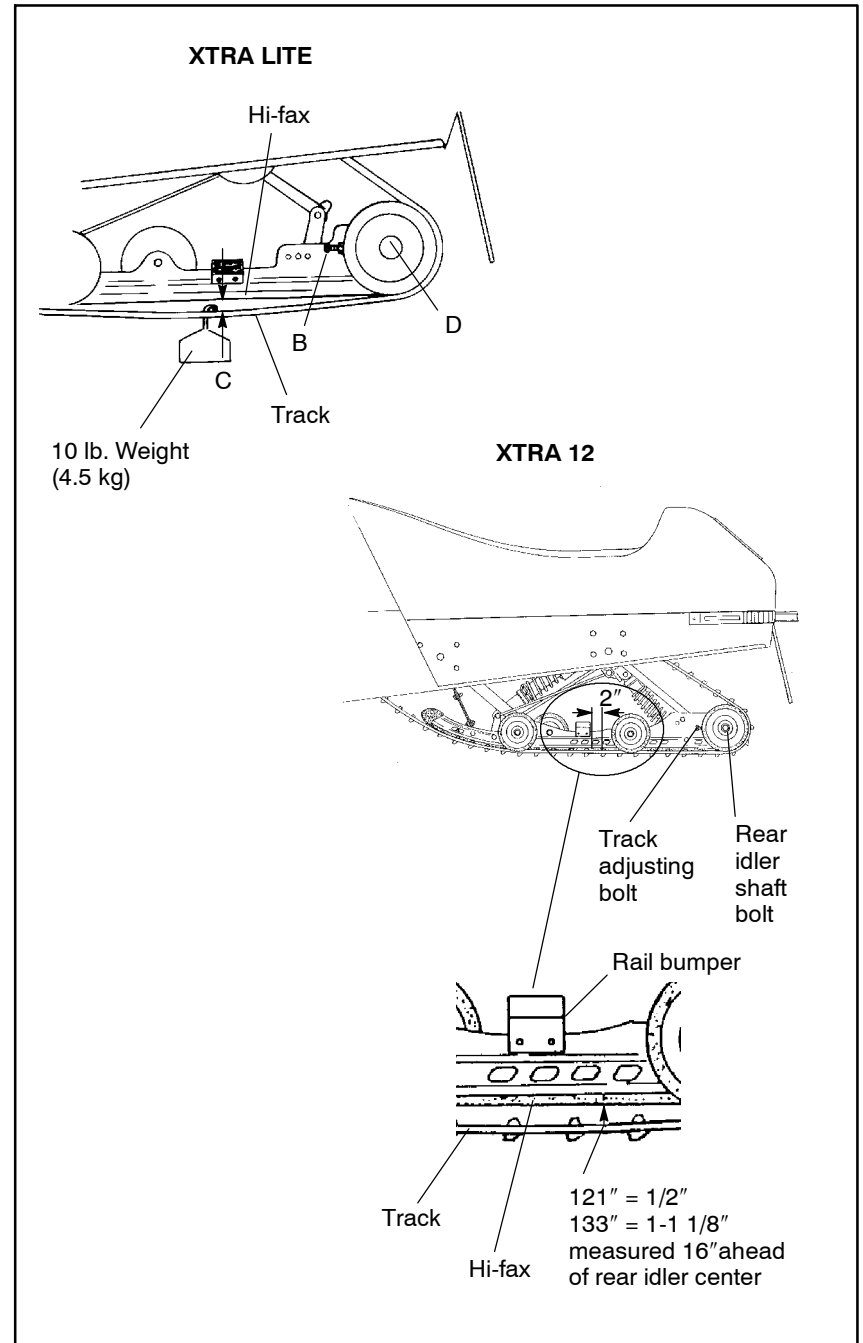

MAINTENANCE

WARNING

When performing the following checks and adjustments, stay clear of all moving parts to avoid serious personal injury.

Track Alignment

A periodic check should be made to see that the track is centered and running evenly on the slide rails. Misalignment will cause excessive wear to the track and slide rail. **NOTE:** If excessive hi-fax wear occurs due to poor snow conditions, additional wheel kits are available. Consult your dealer.

1. Safely support the rear of the machine with the track off the ground.
2. Start the engine and apply a small amount of throttle until the track turns *slowly* at least five complete revolutions. Stop the engine.
3. Inspect track alignment by looking through the track window to make sure the rails are evenly spaced on each side. If the track runs to the left, loosen left locknut and tighten the left adjusting bolt. If the track runs to the right, loosen right locknut and tighten the right adjusting bolt.
4. After adjustments are complete, be sure to tighten locknuts and idler shaft bolts. Torque to 35-40 ft. lbs. (4.8-5.5 kg/m).
5. Repeat step 2 to verify proper alignment.

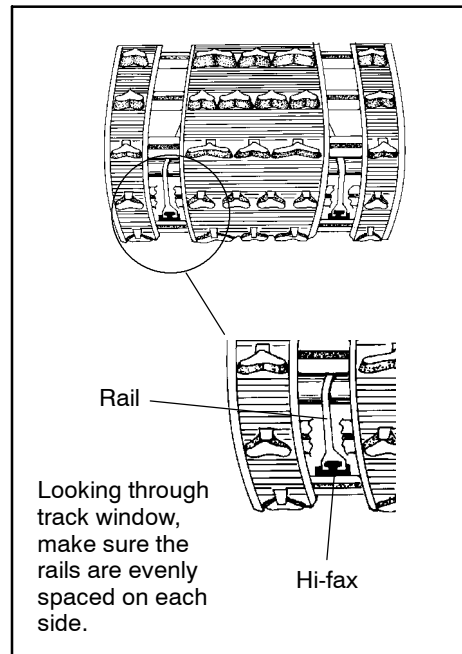

Track Warm Up

When storing your snowmobile outside overnight, it is recommended that the track be warmed up prior to driving the snowmobile. This reduces belt and drive clutch wear. To warm up the track, safely support the rear of the snowmobile off the ground, start the engine and *abruptly* engage the clutch. Allow the track to turn for a short time. Release the throttle, apply the brakes and shut the engine off prior to lowering it to the ground.

WARNING

Your snowmobile is propelled by a revolving track which must be partially exposed for proper operation. Serious injuries may be caused by operator carelessness resulting in hands, feet, or clothing becoming entangled in the track. Be alert. Remember, being properly seated keeps you clear of the track.

Never hold the snowmobile up or stand behind it while warming up the track. A loose track or flying debris could cause serious personal injury or death.

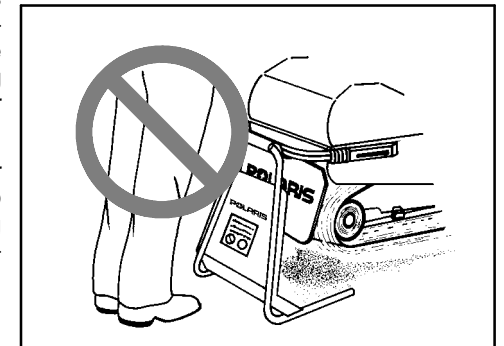
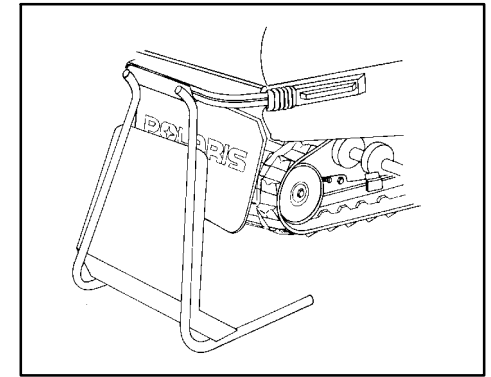

MAINTENANCE

Track Inspection

⚠ WARNING

Never make this maintenance check with the engine running, as serious personal injury can result.

Using a hoist, safely lift and support the rear of the snowmobile off the ground. Rotate the track by hand to check for any possible damage.

To inspect track rods, carefully examine the track along the entire length of each rod, bending the track and inspecting for breakage. The three most common places where breakage occurs are shown in the illustration.

If any rod damage is found, the track should be replaced.

⚠ WARNING

Broken track rods are a serious hazard, since they can cause a rotating track to come off the machine. *Never* operate or rotate a torn or damaged track under power. Serious personal injury or death may occur.

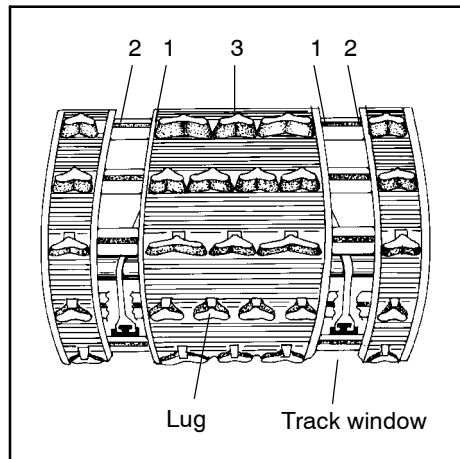

Track Lubrication

WARNING

Track failure, loss of vehicle control and braking ability can result from extended use of this vehicle on surfaces providing marginal lubrication between hi-fax and track guide clips. Examples of marginal lubrication would include lakes without snow cover, icy trails and no-snow conditions.

The slide rail is designed to operate in conditions with adequate snow cover in order to provide sufficient lubrication. Excessive wear indicates insufficient lubrication. New hi-fax can cause faster heat build up in limited lubrication than used hi-fax, resulting in excessive wear. **NOTE:** If excessive hi-fax wear occurs due to poor snow conditions, additional wheel kits are available. Consult your dealer.

CAUTION:

Track damage or failure caused by operation on ice or poor lubrication conditions will void the track warranty.

Traction Products

NOTE: Tracks with deep lug design cannot be studded.

CAUTION:

Polaris does not recommend the use of traction products on WideTrak snowmobiles.

CAUTION:

If traction products are to be added to the track, wear strips must be installed in the tunnel to avoid excessive wear. This applies to all models.

Shims should never be added to the wear strip or track damage will result due to lack of clearance between upper carrier wheels and track.

Use of studs greater than 1" (2.5 cm) on machines equipped with center coolers will result in center cooler damage, or damage to tunnel.

Always inspect for track damage before using the vehicle. Use of traction products such as studs, ice growers, paddles, etc. will increase the possibility of track damage and/or failure, which could cause loss of control resulting in severe injury or death.

In the event you wish to install studs, carbides or ice growers, contact your Polaris dealer for advice.

Track damage or failure resulting from improper or excessive stud installation voids any track warranty, as does installation of the Hooker™ stud system.

MAINTENANCE

WARNING

Proper balance of traction products on the skis and track must be maintained to obtain proper vehicle control on hard packed snow or ice. Loss of control can result in severe personal injury or death.

If your machine is equipped with carbide skags or you are adding them, it may also be necessary to add track studs in order to maintain proper vehicle control while turning on hard packed snow or ice.

Track Studding

IMPORTANT: Before equipping your machine with traction products, be aware of the laws in your area pertaining to the use of traction products.

Track studding will enhance braking control on hard packed snow or ice, but extreme caution is still required on such surfaces. Use extra caution when track studding is employed as steering ability may be reduced on hard packed snow or ice.

The addition of carbide skags (if not already installed) is recommended with studded tracks to aid in maintaining proper vehicle steering and control. Proper balance must be maintained between the number of studs and the length of carbide on skags. As a rule of thumb, the more studs, the longer the carbide on the skags should be. Polaris offers carbide skags in 3", 4", 5", 6", 8", 10" (7.6, 10.2, 12.7, 15.2, 20.3, 25.4 and 35.6 cm) lengths.

Inspect carbide skags and studs frequently. Worn studs or skags can reduce steering and braking control on hard packed snow and ice. Replace worn traction products as required to maintain proper balance and vehicle control.

When studded tracks are used, increased wear to the brake pads will result from increased braking effort. Extended wear brake pad kits are available. See your dealer for more information.

Tunnel wear strips *must* be installed whenever track studding is used in order to avoid excessive tunnel wear. Several wear strips are available. See your dealer for the correct part for your machine.

See dealer track studding chart for recommended studding and skags.

CAUTION: When using some aggressive studding patterns, it may be necessary to grind protruding stud bolts flush to prevent idler wheel damage.

CAUTION: Track tension must be maintained on the tight side of spec when studs are used to prevent front engine heat exchanger damage.

CAUTION: Center of stud must be at least 1 1/8" (2.86 cm) from the edge of the outer belt.

Wear Strips

Most models come from the factory with tunnel wear strips or wear strip coolers installed. Check your specification supplement to see if your model has wearstrips. These wear strips are designed for a specific stud length. See your dealer's studing chart for recommended traction accessories.

CAUTION:

Use of studs greater than 1" (2.5 cm) on machines equipped with center coolers will result in center cooler damage.

Whenever wear strips are relocated, check to be sure there is adequate stud clearance to the heat exchangers. Without proper clearance damage to heat exchangers will result.

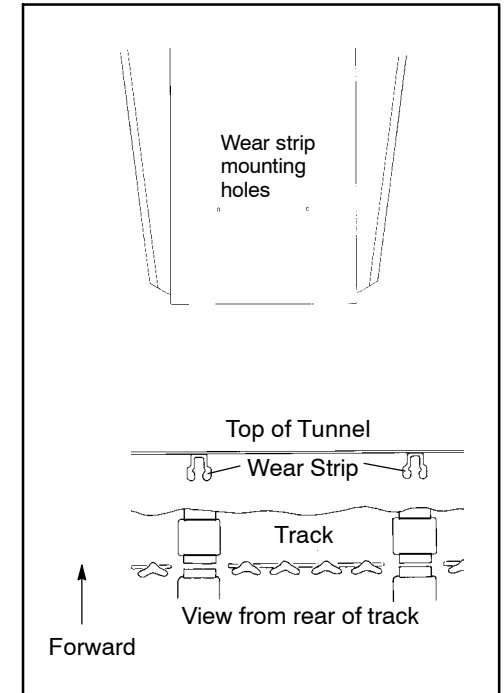

MAINTENANCE

Steering System

The steering systems on Polaris snowmobiles have the following adjustments:

- Ski toe or alignment
- Handlebar centering
- Spindle camber

Improper adjustment of these components can cause erratic steering. Consult your dealer if a need for adjustment should become necessary.

Steering Inspection and Adjustment

The steering assembly of the machine should be checked periodically for loose nuts and bolts. See A,B,C,D,E,F and G in illustration at right.

With handlebars in straight ahead position and measuring from the straight edge of the skis, the measurement between the skis at point H should be 1/8 to 1/4 inches greater than point I. Refer to illustrations on page 99 for component locations.

NOTE: This measurement should be taken with the vehicle weight compressing the suspension. If the skis are misaligned, we recommend that your dealer correct this, as the camber adjustment may also be affected.

WARNING

Do not attempt to change the ski alignment or camber adjustment. Contact your Polaris dealer. Improper alignment or adjustment may cause loss of steering control, resulting in serious injury or death.

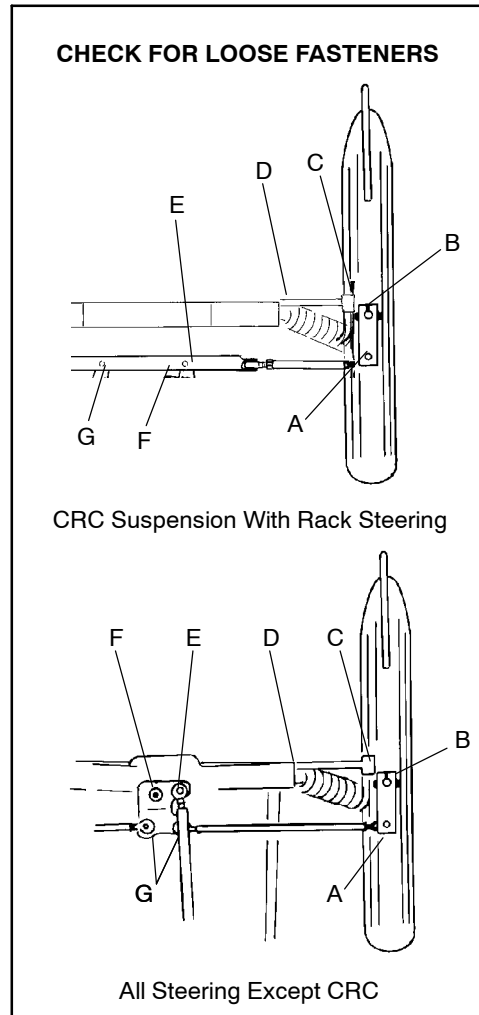

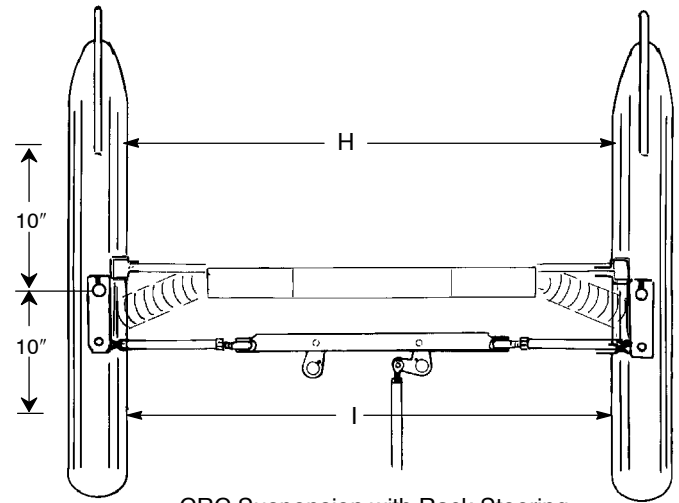

CRC Suspension with Rack Steering

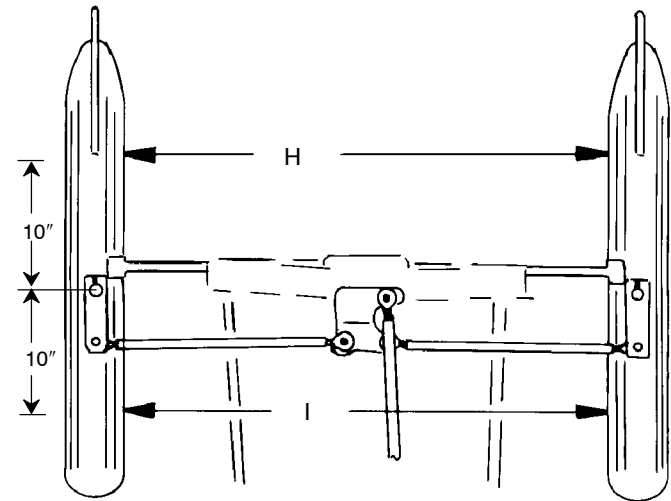

All other steering systems

MAINTENANCE

Ski Skags

The skag is a replaceable bar attached to the underside of the ski. The purpose of the skag is to assist in turning the snowmobile and to prevent the wearing away of the ski caused by contact with roads and other bare terrain. We recommend that skags be checked once a week to maintain positive steering characteristics. Skags must be replaced when worn to half their original diameter. **NOTE:** See dealer track studding and skag chart for recommended skags.

WARNING

Worn skis and/or skags will adversely affect handling. See your dealer's studding chart for recommended skags.

WARNING

If you install longer or more aggressive carbide skags than the original equipment, it may also be necessary to add track studs in order to maintain proper vehicle control while turning on hard packed snow or ice. Loss of vehicle control may cause serious injury or death.

Skag Replacement

1. Raise and support the front of the machine so the skis are approximately 6" (15.2 cm) from the ground.
2. Remove the attaching nuts and pry the skag downward.
3. Remove the forward portion of the skag.

Reverse this procedure for new skag installation.

CAUTION:

Avoid excessive tipping of the machine, causing the carburetor(s) to overflow from their vent(s). Spilled fuel may cause damage to plastic or painted finishes.

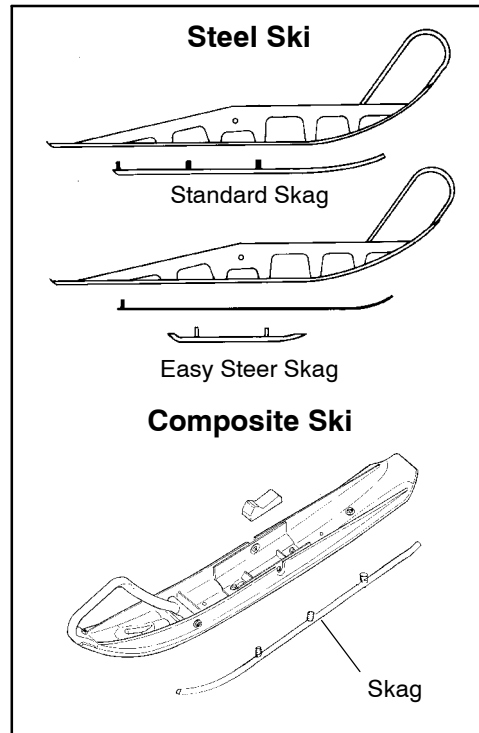

MAINTENANCE

Hi-Fax Wear

Hi-fax wear patterns are somewhat different on XTRA™-12 suspension models. The rear portion will wear rapidly at first. After this initial break in period the rapid wear will cease. Replacement is not necessary until a thickness of 5/16" (.8 cm) is reached. Check Hi-fax wear by measuring at several points along the rail. Take the machine to your dealer for Hi-fax replacement.

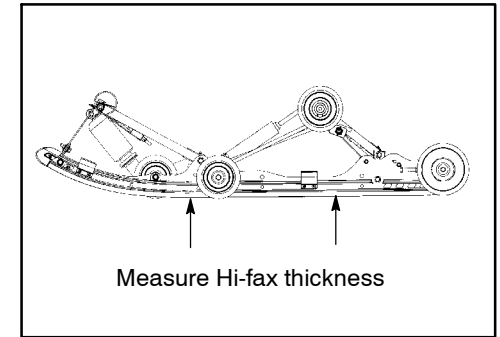

Suspension Maintenance

A visual inspection of the following items should be done on a weekly basis or before any long distance trip:

- Suspension pivot arm bolts for tightness
- Rear idler wheel bolts for tightness
- Rear idler adjusting bolt locknuts for tightness
- Bogie wheels and attaching bolts for tightness
- Suspension mounting bolt tightness - torque to 60 ft. lbs. (8.3 kg/m) on Xtra-12 models; all others torque to 40 ft. lbs. (5.52 kg/m)
- Front torque arm limiter strap condition
- Slide rail Hi-fax condition greatly affects performance - have your dealer replace when worn to Minimum Thickness (see illustrations at right).

NOTE: If excessive hi-fax wear occurs due to poor snow conditions, additional wheel kits are available. Consult your dealer.

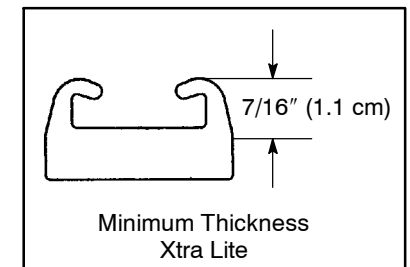
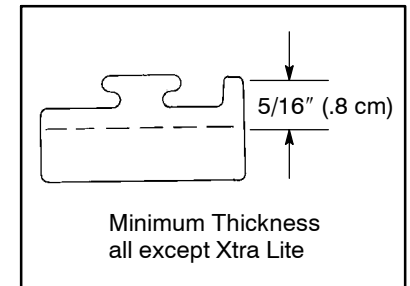

Make it a weekly practice to check for loose bolts and nuts on the suspension system. If any loose bolts are found on the rail beam be sure to clean threads and apply Loctite 262 before tightening.

On models with the Xtra-12 suspension, the four main 7/16" bolts securing the suspension to the tunnel should be torqued to 60 ft. lbs. (8.3 kg/m), all other 3/8" bolts should be torqued to 40 ft. lbs. (5.5 kg/m), on XTRA-Lite suspensions, the 5/16" bolts should be torqued to 25 ft. lbs.

MAINTENANCE

CAUTION:

If suspension bolts are removed, the threaded shaft must be cleaned thoroughly with a brake parts type cleaner. A new bolt, which must have a locking patch on the threads, must be installed. See your dealer for the correct fastener for this application.

If rear idler wheel (1) assembly washers are removed, be sure they are reinstalled with the domed side of the washer facing out (2) as shown.

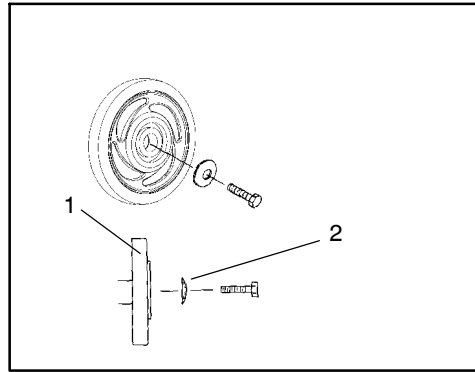

Suspension Lubrication

To maintain rider comfort and to retard wear of the pivot shafts, the suspension pivot shafts should be lubricated with Polaris Premium All Season Grease, PN 2871066, at 500 miles (800 km) initially; 1000 miles (1600 km) and before summer storage each year. The riding characteristics of the snowmobile will be affected by lack of lubrication of these shafts. **NOTE:** A grease gun kit complete with grease and adaptors is available to lubricate all fittings on Polaris snowmobiles. Order PN 2871312.

Refer to the diagrams on the following pages for suspension lubrication points.

For detailed information regarding suspension lubrication and adjustments, contact your Polaris dealer.

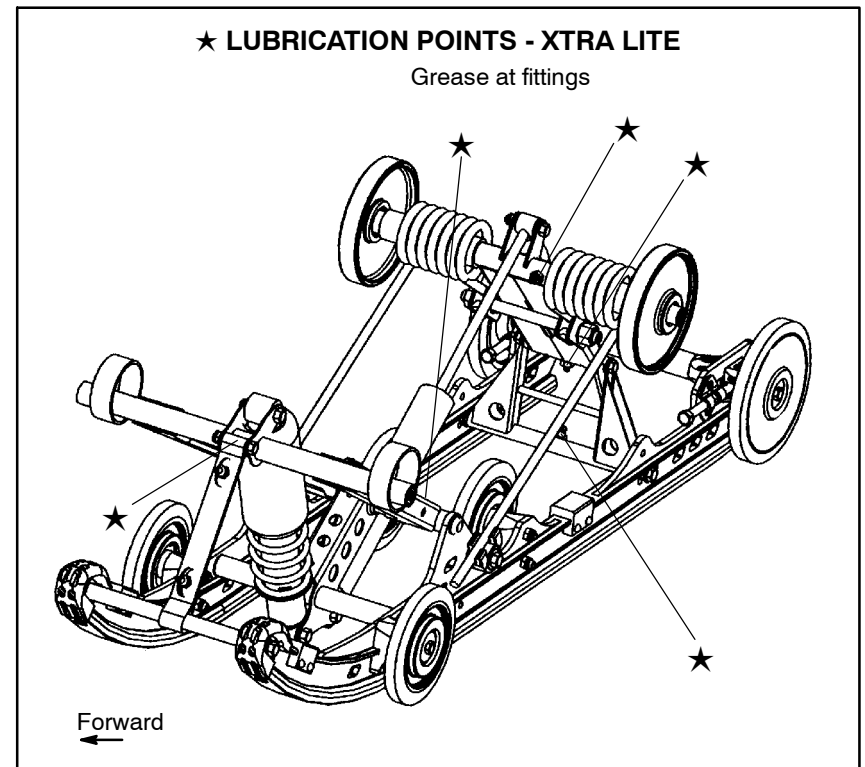

MAINTENANCE

Suspension Lubrication

NOTE: The following illustrations are general representations. Your model may differ. Lubrication points are indicated by a ★ and forward is to the left.

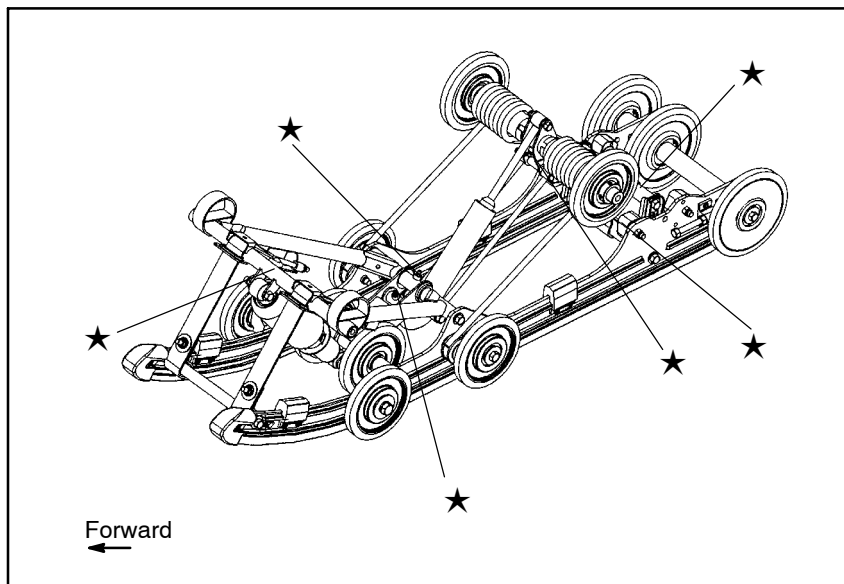
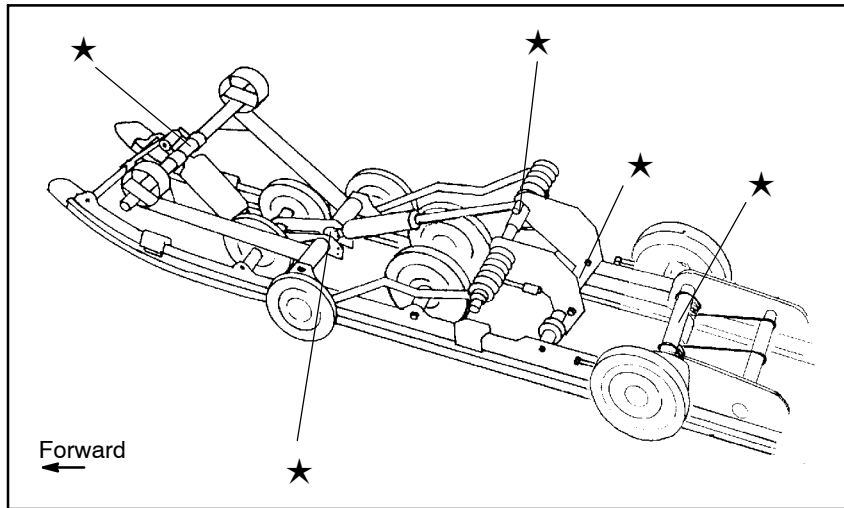

Suspension Lubrication

NOTE: The following illustrations are general representations. Your model may differ. Lubrication points are indicated by a ★ and forward is to the left.

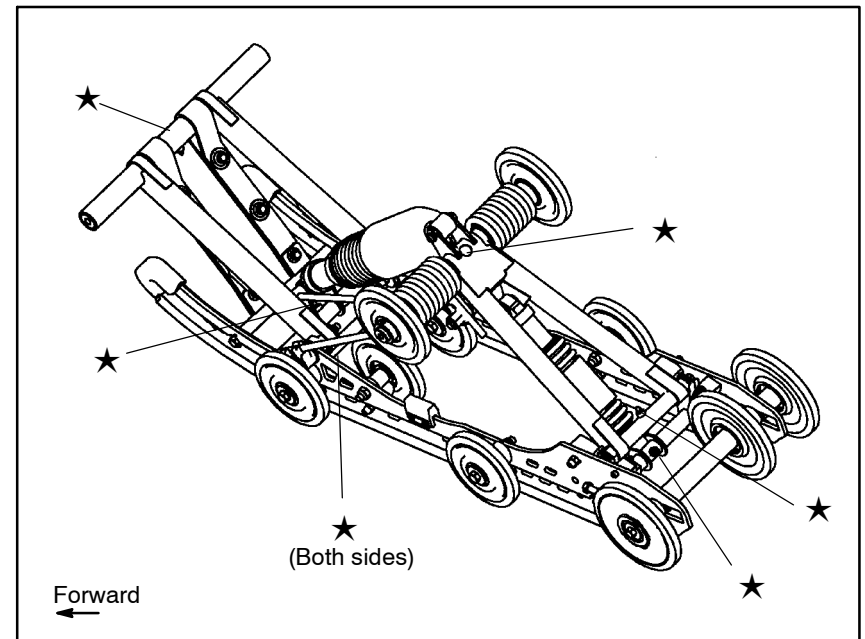

SUSPENSION

Independent Front Suspension (IFS) Components

Refer to illustrations on following pages. **NOTE:** Illustrations are a general representation. Your model may differ.

1. IFS Compression Spring
2. IFS Shock Absorber
3. Trailing Arm
4. Ski Spindle
5. Ski Pivot
6. Ski Stop
7. Ski Pivot Bushing
8. Lower Radius Rod
9. Upper Radius Rod

SUSPENSION

Independent Front Suspension (IFS) Components

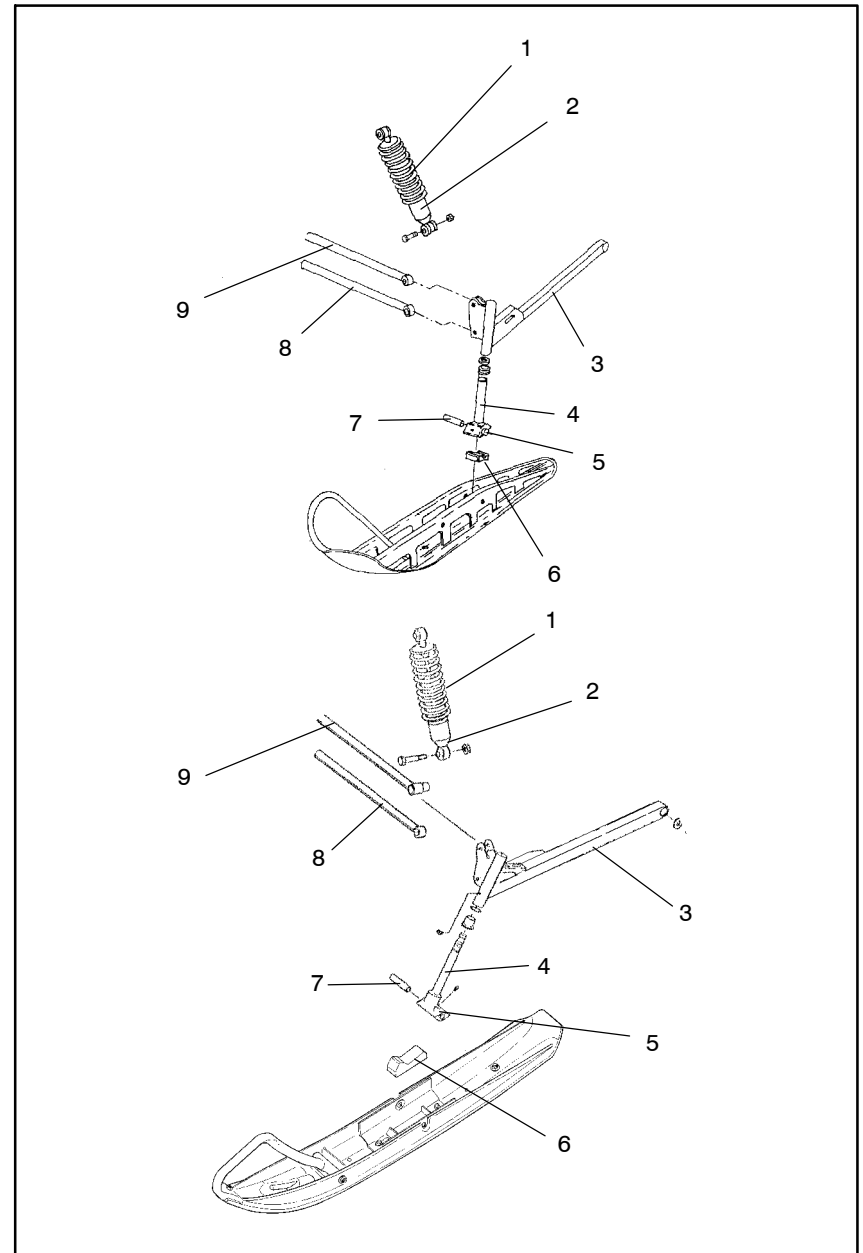

SUSPENSION

IFS Adjustment and Ski Pressure

Increasing spring preload will increase ski to ground pressure. Decreasing spring preload will decrease ski to ground pressure under all throttle positions. **NOTE:** Increasing the IFS spring preload too far can adversely affect the handling of the snowmobile and rear suspension performance.

To adjust spring preload on the ski, grasp the spring and turn in a clockwise direction (as viewed from the bottom of the shock) to increase the preload. Turn in a counterclockwise direction to decrease preload. **NOTE:** Reducing the spring preload too much may allow the spring retainer to fall off. Always leave at least one thread showing above the nut (A).

NOTE: In the adjacent illustrations, (B) indicates High Preload and (C) indicates low preload.

CAUTION: If the plastic nut is unscrewed from the threaded body the nut will break. Always leave one thread showing above the plastic nut or the spring coils will stack, resulting in damage.

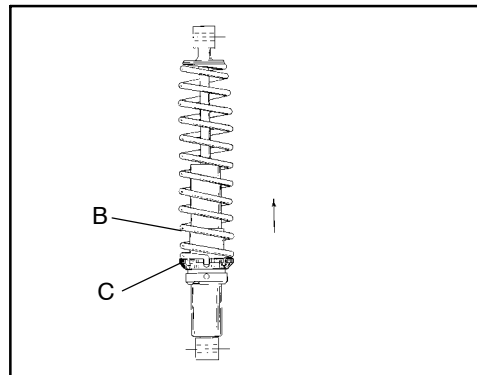
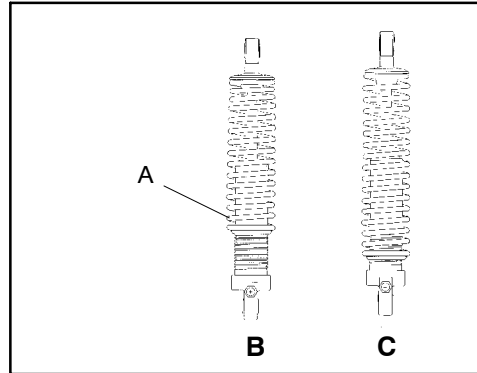

IFS Adjustment

Shock Absorber Components

1. Retainer
2. Shock Rod
3. Jounce Bumper
4. Body

When adjusting, be sure springs on both the left and right sides of the machine are at the same adjustment.

For the best ride the spring preload should be as low as possible. Set the preload to use the full travel of the ski shock with occasional light bottoming. To determine if your machine is using full travel, push the shock jounce bumper down as far as it will go on the shock rod and test ride the machine.

The bumper will move up on the rod in direct relation to the amount of travel. For example, if the shock travel is full, the bumper will be seated at the top of the shock.

The purpose of the shock coil spring is to control ride height. The purpose of shock valving is to control damping. If you find that in order to obtain the desired ride effect the spring preload is at its maximum, consider removing the existing spring and install the next highest rate spring.

- Remove the existing spring and install the next highest rate spring, or
- Reduce the preload on the existing spring and change the shock valving to obtain the desired effect.

WARNING

Changing shock valving on Fox™ shocks requires special tools and a sound knowledge of mechanical theory, tool use, and shop procedures in order to perform the work safely and correctly. Shocks contain high pressure nitrogen gas. Extreme caution should be observed when handling and working with high pressure service equipment. This work should be performed by a Polaris dealer.

Always verify ski alignment before making adjustments to the IFS. See page 98 to check alignment. If the skis are misaligned, we recommend that your dealer correct this, as the camber adjustment may also be affected.

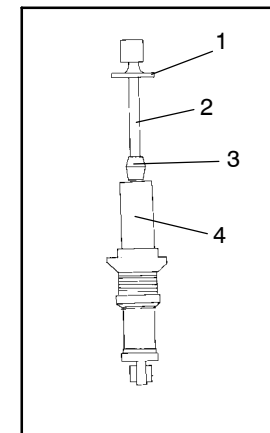

SUSPENSION

“Indy Select” IFS Shock

Some snowmobiles are equipped with “Indy Select” IFS shocks, which allow the driver to make adjustments to the compression valving of the front shocks by turning adjustment screws (A) located near the base of the shocks.

By turning the screw clockwise, the compression of the shock increases, stiffening the ride. By turning counter clockwise, the compression decreases, softening the ride. The factory setting is in the softest position. (Screw all the way out - counter-clockwise). If bottoming occurs, the “Select” feature should be used in conjunction with the spring preload to achieve the desired ride affect. One-half turn will affect the ride considerably. There are approximately 3 turns of adjustment available.

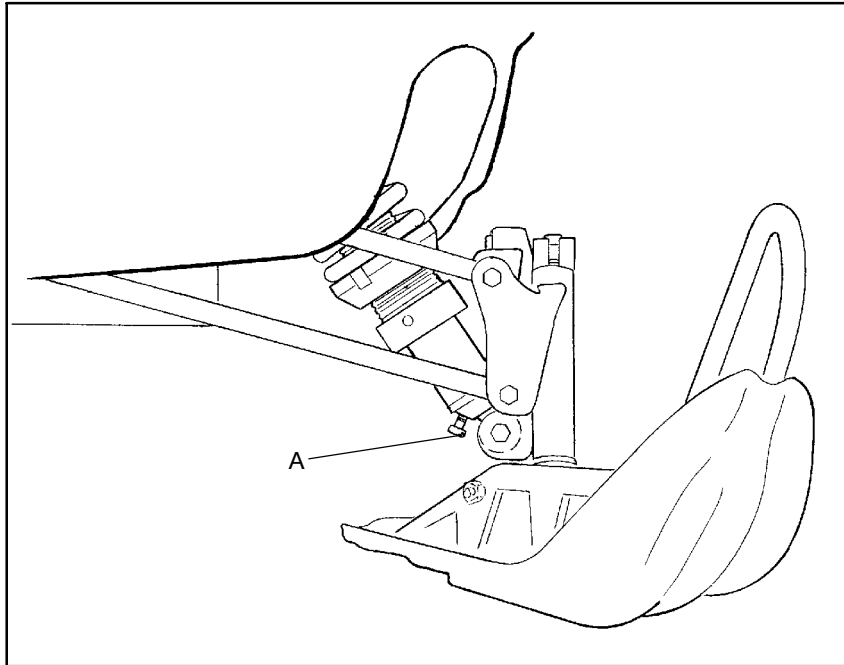

SUSPENSION - XTRA 10

Refer to illustrations on following pages. **NOTE:** Illustrations are a general representation. Your model may differ.

1. Compression Valving Adjustment Screw
2. Rear Limiter Strap
3. RRSS (Rear Rear Scissor Stop)
4. FRSS (Front Rear Scissor Stop)
5. Limiter Strap (Adjustable)
6. Limiter Strap (Quick Adjust)
7. Rear Torsion Spring Adjuster(Cam - Low Position Shown)
8. Front Limiter Strap
9. Front Track Shock
10. Torsion Spring
11. Pivot Arm Shaft
12. Rear Track Shock
13. Carrier Wheel
14. Coil Spring
15. Rear Scissor
16. Rail Tip
17. Hi-fax
18. Slide Rail
19. Rail Bumper
20. Bogie Wheel
21. Rear Limiter Strap Adjuster
22. Idler Wheel
23. Front Torque Arm

SUSPENSION

Rear Suspension Components - Xtra-10 Type

NOTE: General representation only.
Your model may differ.

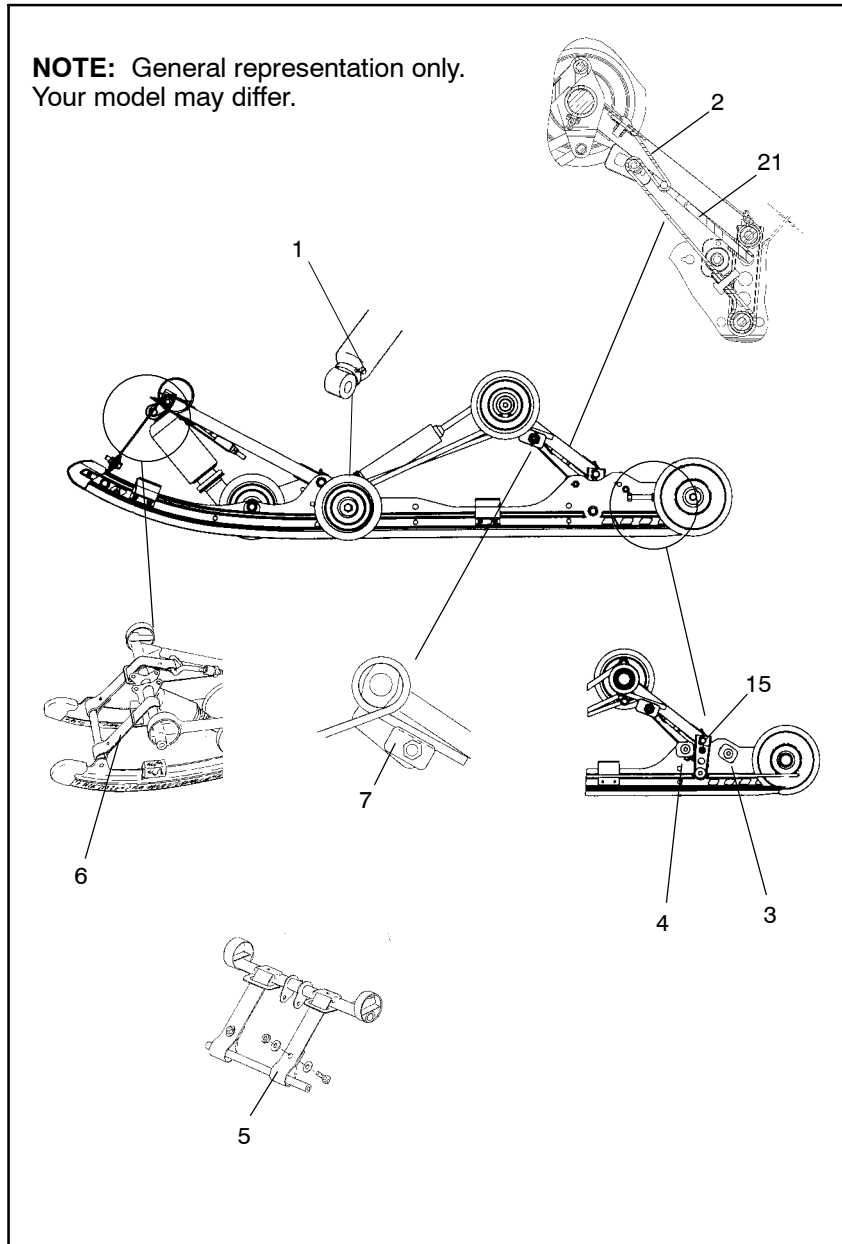

SUSPENSION

Rear Suspension Components - Xtra-10 Type

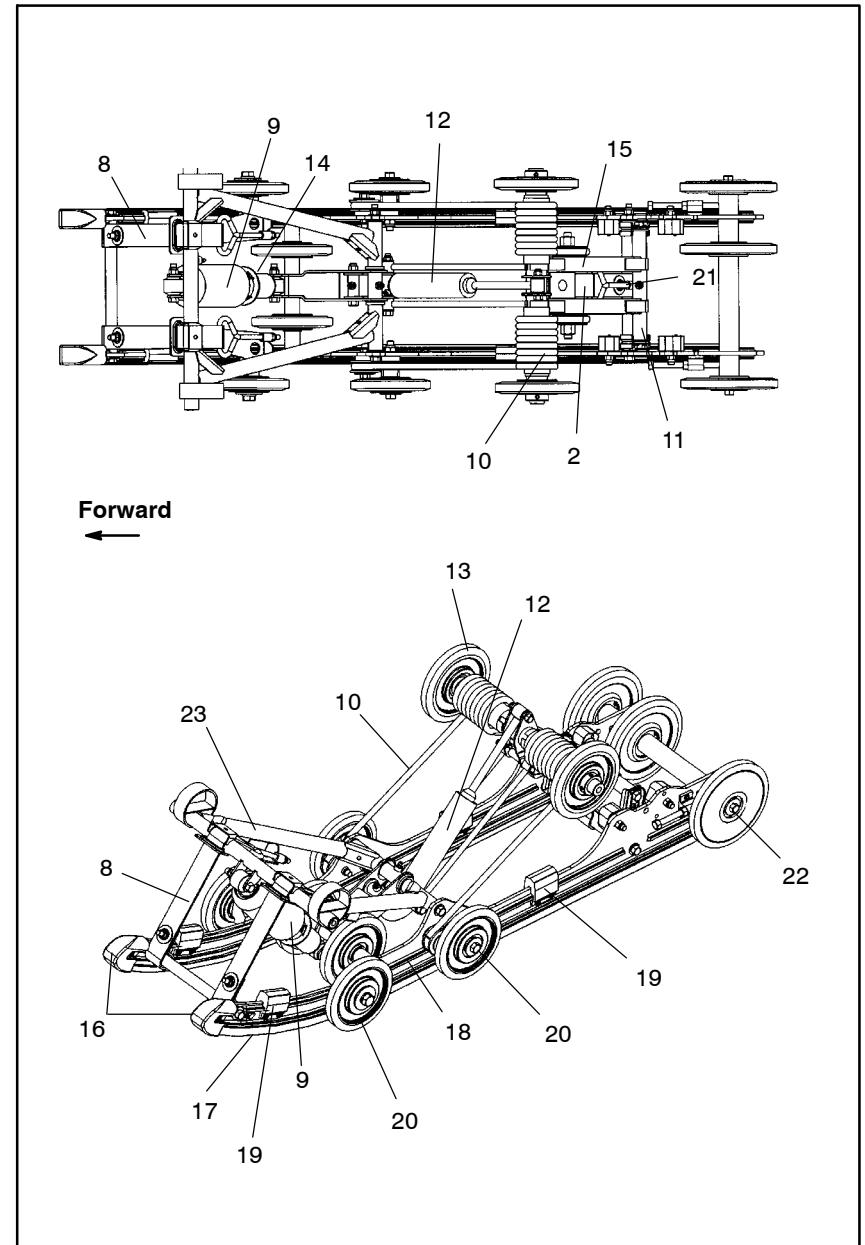

SUSPENSION

Suspension Adjustment

The XTRA™ 10 suspension has been designed and set up to deliver a soft ride under average riding conditions. Rider weight, riding styles, trail conditions, and vehicle speed each affect suspension action.

The suspension can be adjusted to suit rider preference and deliver excellent performance for a given set of conditions. It should be noted, however, that suspension adjustments involve a compromise or trade off. A machine set up to perform well in the moguls might not suit the preference of a groomed trail rider.

Adjustable Features and Adjustment Options

Independent Front Suspension (IFS)

- Front shock spring preload
- Optional springs
- Optional valving

Rear Suspension

- Torsion Spring Preload
- Front rear scissor stop (FRSS)
- Rear rear scissor stop (RRSS)
- Optional coil springs for front track shock
- Optional torsion springs
- Limiter straps - front and rear
- Indy Select/Select AFX Rear Track Shock (if equipped)
- Optional valving (Fox™ equipped models only)

Adjustment Procedures

It is a good idea to break the suspension in for approximately 150 miles (240 km) and re-grease all suspension parts before fine tuning adjustments are made.

All settings will vary from rider to rider, depending on rider weight, vehicle speed, riding style, and trail conditions. We recommend starting with factory settings and then customizing each adjustment individually to suit rider preference. The machine should be methodically tested under the same conditions after each adjustment (trail and snow conditions, vehicle speed, riding position, etc.) until a satisfactory ride is achieved. Adjustments should be made to one area at a time, in order to properly evaluate the change. Detailed Descriptions of suspension adjustments are located further back in this owner's manual.

SUSPENSION - XTRA 12

Refer to illustrations on following pages. **NOTE:** Illustrations are a general representation. Your model may differ.

1. Compression Valving Adjustment Screw
2. RRSS (Rear Rear Scissor Stop)
3. FRSS (Front Rear Scissor Stop)
4. Limiter Strap (Adjustable)
5. Rear Torsion Spring Adjuster(Cam - Low Position Shown)
6. Front Track Shock
7. Torsion Spring
8. Rear Track Shock
9. Carrier Wheel
10. Rear Track Shock Coil Spring
11. Rear Scissor
12. Rail Tip
13. Hi-fax
14. Slide Rail
15. Bogie Wheel
16. Rail Bumper
17. Front Track Spring
18. Idler Wheel
19. Front Torque Arm

SUSPENSION

Rear Suspension Components - Xtra-12 Type

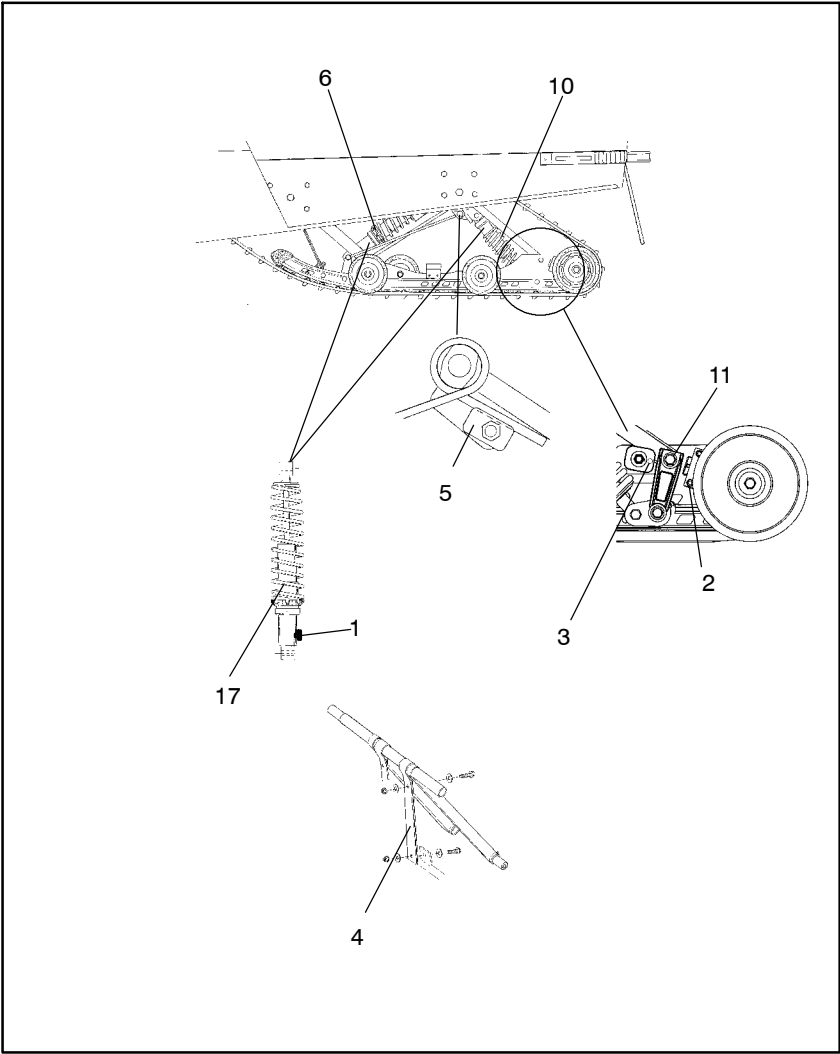

Rear Suspension Components - Xtra-12 Type

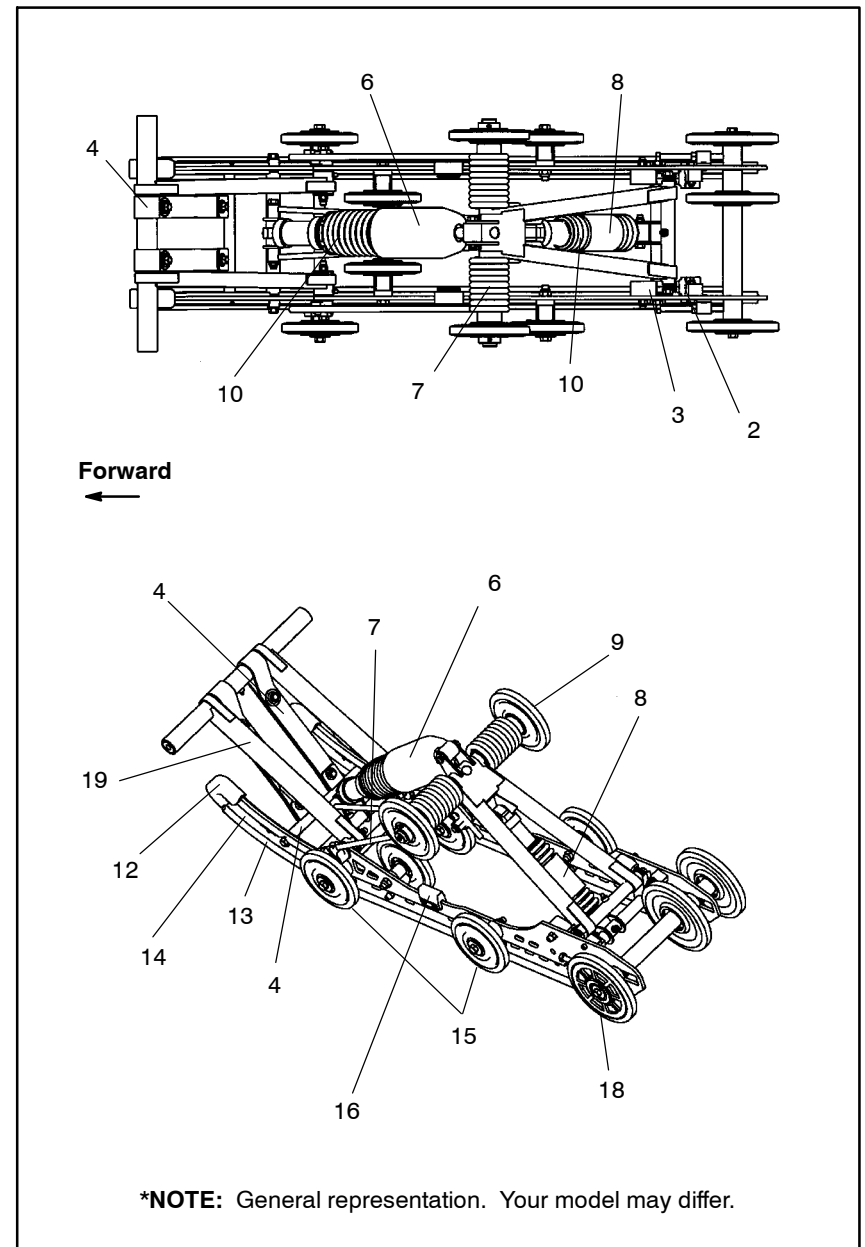

SUSPENSION

Suspension Adjustment

The XTRA™ 12 suspension has been designed and set up to deliver a soft ride under average riding conditions. Rider weight, riding styles, trail conditions, and vehicle speed each affect suspension action.

The suspension can be adjusted to suit rider preference and deliver excellent performance for a given set of conditions. It should be noted, however, that suspension adjustments involve a compromise or trade off. A machine set up to perform well in the moguls would not suit the preference of a groomed trail rider.

Adjustable Features and Adjustment Options

Independent Front Suspension (IFS)

- Front shock spring preload
- Optional springs
- Indy Select/Select AFX compression adjustment (if equipped)

Rear Suspension

- Spring preload - front track shock
- Rear torsion spring preload
- Front rear scissor stop (FRSS)
- Optional coil springs for front track shock
- Optional torsion springs
- Limiter strap - front
- Indy Select/Select AFX front and rear track shocks (if equipped)
- Optional coil springs for rear track shock

Adjustment Procedures

It is a good idea to break the suspension in for approximately 150 miles (240 km) and re-grease all suspension parts before fine tuning adjustments are made.

All settings will vary from rider to rider, depending on rider weight, vehicle speed, riding style, and trail conditions. We recommend starting with factory settings and then customizing each adjustment individually to suit rider preference. The machine should be methodically tested under the same conditions after each adjustment (trail and snow conditions, vehicle speed, riding position, etc.) until a satisfactory ride is achieved. Adjustments should be made to one area at a time, in order to properly evaluate the change. Detailed descriptions of suspension adjustments are located further back in this owner's manual.

SUSPENSION

Rear Suspension Components - Xtra Lite Type

Refer to illustrations on following pages. **NOTE:** Illustrations are a general representation. Your model may differ.

1. Front Track Shock
2. Torsion Spring
3. Rear Track Shock
4. Carrier Wheel
5. Rail Tip
6. Hi-fax
7. Slide Rail
8. Bogie Wheel
9. Rail Bumper
10. Front Track Spring
11. Idler Wheel
12. Front Torque Arm
13. Rear Torque Arm
14. Rear Pivot Arm

SUSPENSION

Rear Suspension Components - Xtra Lite Type

NOTE: General representation only.
Your model may differ.

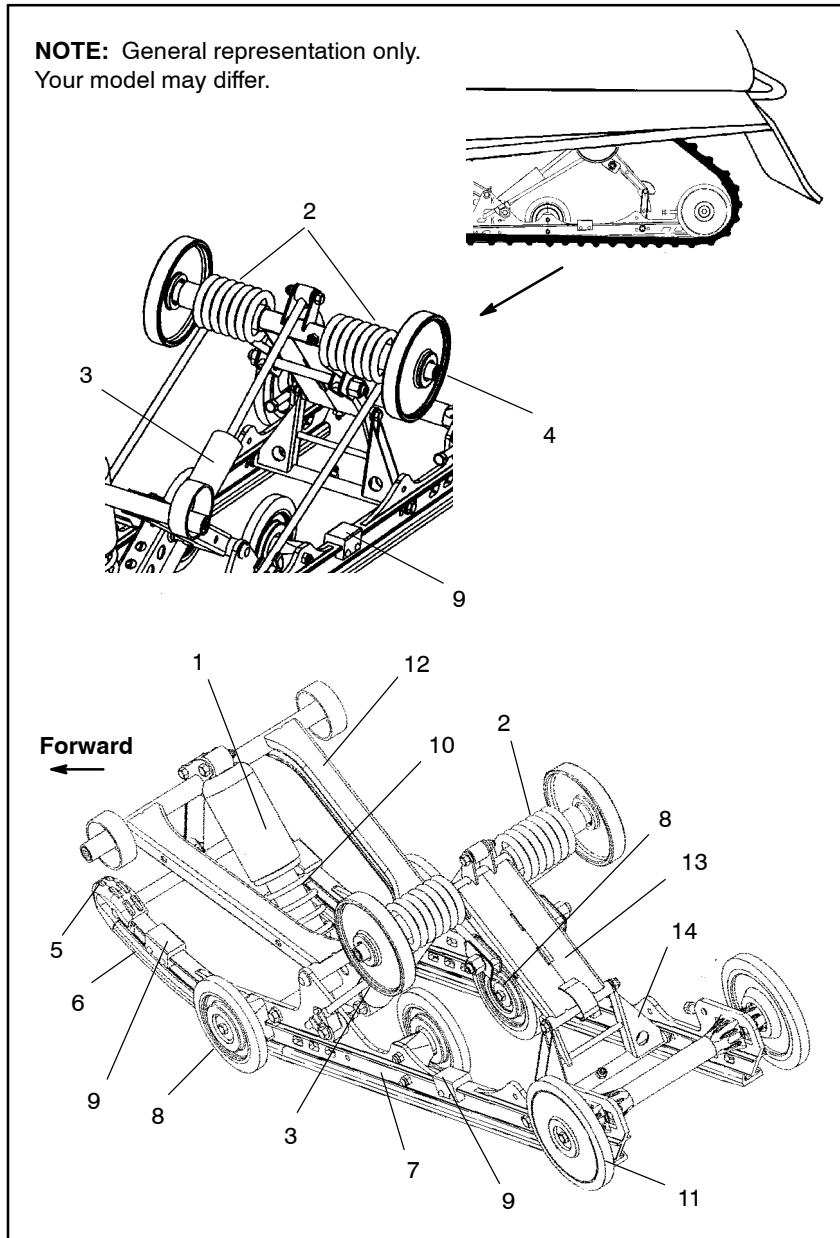

SUSPENSION

Rear Suspension Components - Wide Trak/Tran Sport

Refer to illustrations on following pages. **NOTE:** Illustrations are a general representation. Your model may differ.

1. Front Track Shock
2. Torsion Spring
3. Rear Track Spring
4. Carrier Wheel
5. Rail Tip
6. Hi-fax
7. Slide Rail
8. Bogie Wheel
9. Rail Bumper
10. Front Track Spring
11. Idler Wheel
12. Front Torque Arm
13. Adjuster Eyebolt
14. Rear Shock
15. Rear Torque Arm
16. Rear Pivot Arm

SUSPENSION

Rear Suspension Components - Wide Trak

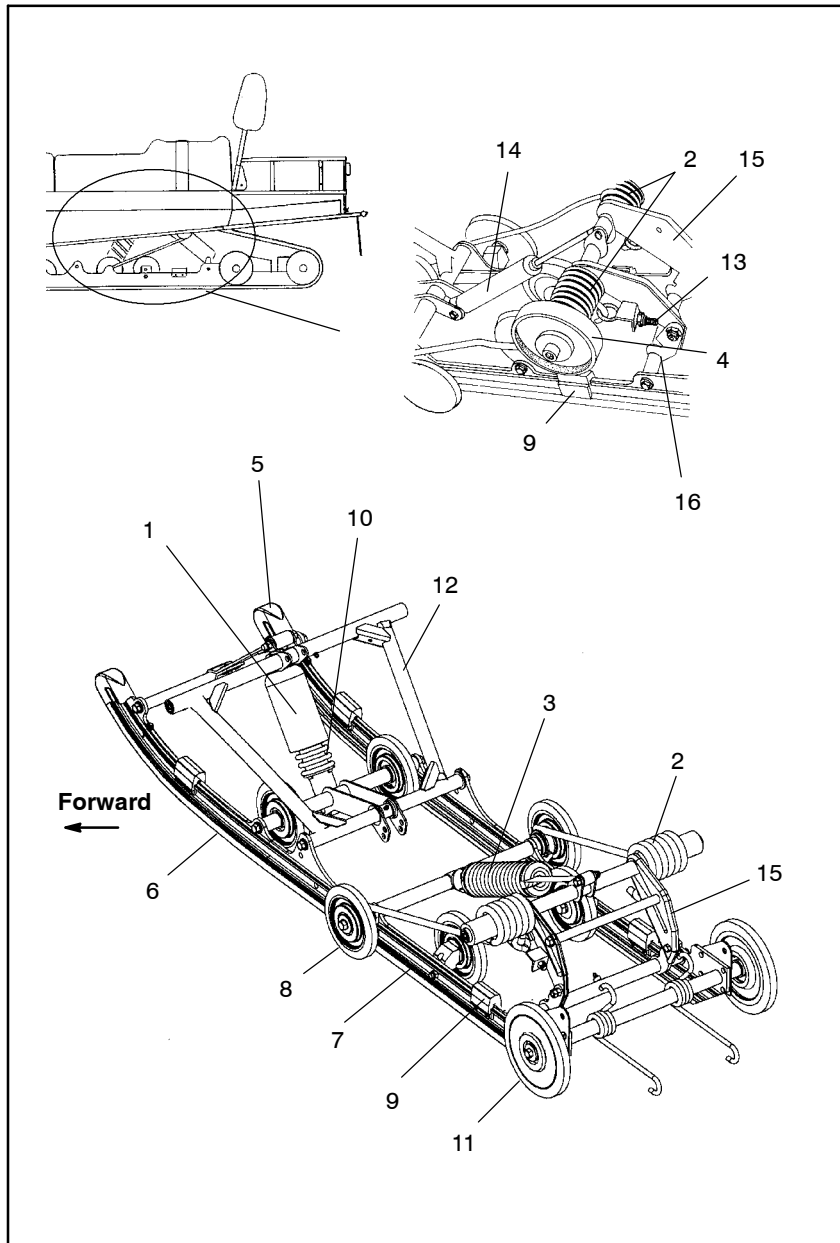

Suspension Adjustment

The Polaris WideTrak and Xtra Lite Type Suspensions have been designed and set up to deliver a soft ride under average riding conditions. Rider weight, riding styles, trail conditions, and vehicle speed each affect suspension action.

The suspension can be adjusted to suit rider preference and deliver excellent performance for a given set of conditions. It should be noted, however, that suspension adjustments involve a compromise or trade off. A machine set up to perform well in the moguls would not suit the preference of a groomed trail rider.

Adjustable Features and Adjustment Options

- Rear torsion spring preload
- Optional coil springs for front track shock
- Optional torsion springs
- Front limiter strap
- Optional coil springs for IFS shocks

Adjustment Procedures

It is a good idea to break the suspension in for approximately 150 miles (240 km) and re-grease all suspension parts before fine tuning adjustments are made.

All settings will vary from rider to rider, depending on rider weight, vehicle speed, riding style, and trail conditions. We recommend starting with factory settings and then customizing each adjustment individually to suit rider preference. The machine should be methodically tested under the same conditions after each adjustment (trail and snow conditions, vehicle speed, riding position, etc.) until a satisfactory ride is achieved. Adjustments should be made to one area at a time, in order to properly evaluate the change.

SUSPENSION

“Indy Select” Rear Shock

Some snowmobiles are equipped with the Indy Select/Select AFX rear shock, which allows the driver to make adjustments to the compression valving of the rear shock by turning the screw located near the base of the shock.

Adjustment

Locate the adjustment screw near the base of the shock. **NOTE:** This adjustment is easiest to make with the machine tipped on its side using the special tool provided in the tool kit that came with your machine.

WARNING

Be sure to shut off the fuel supply before tipping the machine to prevent fuel spillage and flooding of the carburetors.

By turning the screw clockwise (a small screwdriver or dime work well), the compression valving is increased, stiffening the ride. To soften the ride, reduce the compression by turning the screw counter-clockwise. A great deal of ride performance is accomplished with a mere 1/2 to 1 turns. There are approximately 3 full turns of adjustment available.

How to Adjust

Upon initial set-up, it is recommended that the suspension set up decal located on the clutch guard or on the hood be followed. At this point, further adjustments for personal ride preference can be made.

If the suspension is “bottoming,” tighten the compression screw clockwise in 1/2 turn increments until the bottoming stops. Backing off 1/4 turn counter-clockwise at this point should give you the best possible ride ensuring use of the full travel of the suspension. The opposite procedure should be used if the suspension is too stiff upon initial set-up.

If bottoming continues after the screw is bottomed out (turned full clockwise), the torsion spring should be adjusted with the adjustment block. See page 131. Back the screw out to the original starting position after the torsion spring has been tightened.

Riding conditions are ever changing. Keep in mind the Indy Select can be adjusted at any time to achieve the best possible ride in any condition.

Position Sensitive Shock

There are no external adjustments on the position sensitive shock. Consult your dealer if you desire to have the internal valving changed.

“Indy Select” Rear Shock

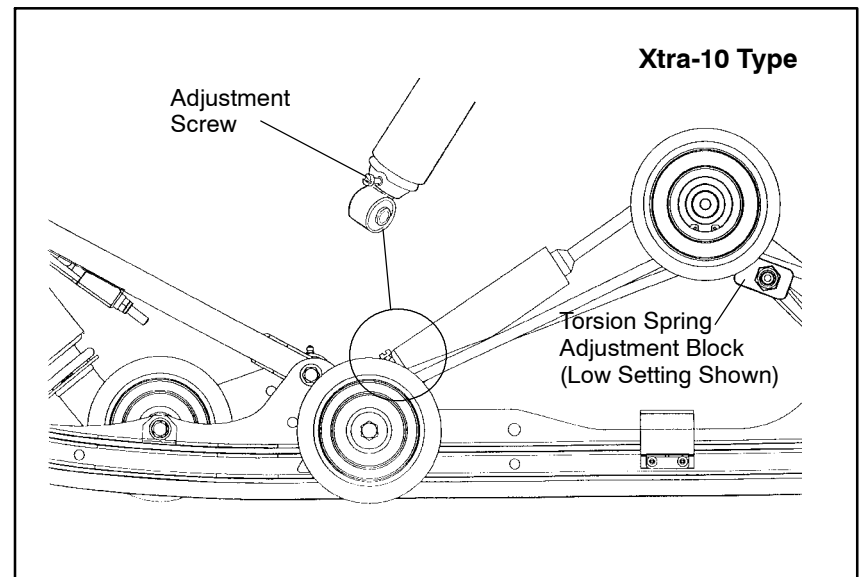
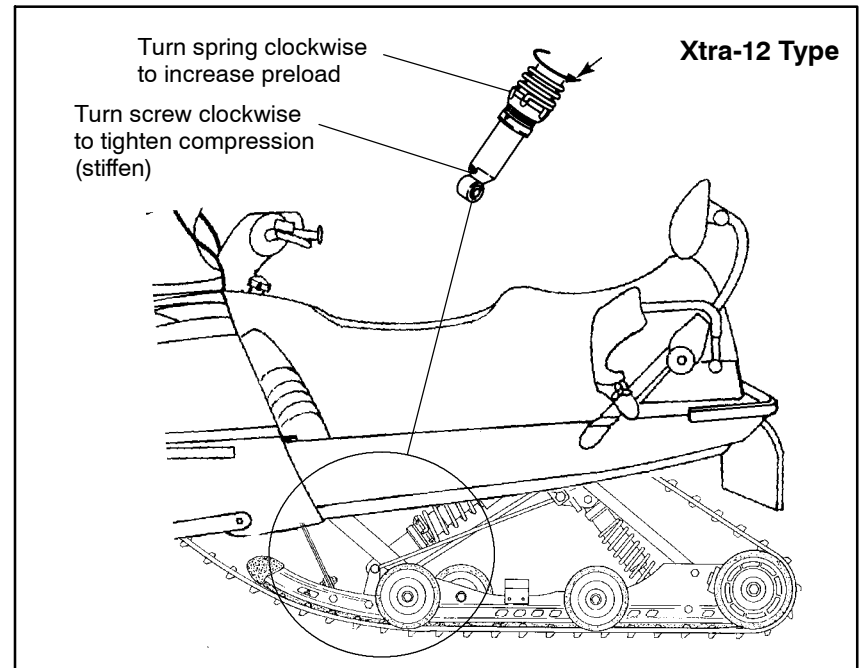

SUSPENSION

Front Torque Arm Limiter Strap Adjustment

One method of changing ski-to-snow pressure is to change the length of the front torque arm limiter straps using the holes provided. The limiter strap is normally mounted in the fully extended position. It is important to note that decreasing limiter strap length will stiffen the whole suspension.

- Lengthening the straps decreases ski pressure under acceleration.
- Shortening the straps increases ski pressure under acceleration.

The preferred method for changing ski pressure under steady throttle condition is to increase or decrease IFS spring preload (only available on some models).

In addition, there are two positions to mount the front track shock. The upper position can be used when reduced ski pressure is desired for ease of steering or deep snow mobility.

Some models are equipped with quick adjust front limiter straps. Adjustment is made by turning the eyebolt nut to lengthen or shorten the straps. To shorten the strap, turn the nut clockwise. To lengthen the strap, turn the nut counterclockwise.

If you need further assistance with ride and handling, contact your Polaris dealer.

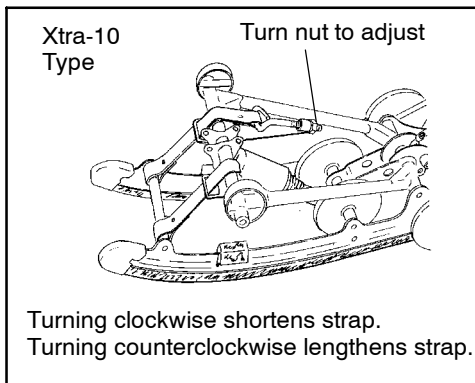
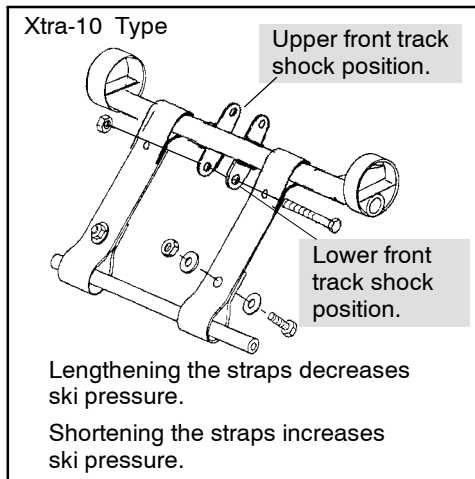
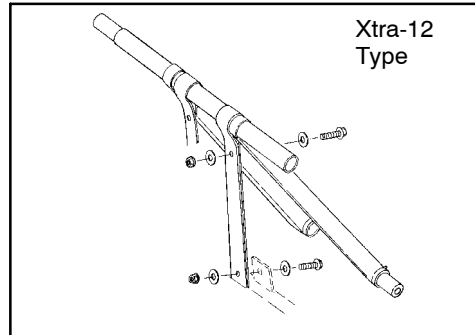

Suspension Set Up

A decal outlining rear suspension set up options is located either on the hood or the clutch cover of your machine. These decals provide a guideline to be used for initial suspension set up. Your set up may vary based on your desired riding style.

Xtra-12 Rear Suspension Adjustments

The primary rear suspension adjustments on Xtra-12 models are the compression valving on both rear suspension shocks, the front track spring preload and the rear torsion spring preload. It is important to note that adjusting the limiter strap does not change weight transfer from the rear suspension to the skis as in a conventional suspension. Instead it will increase the entire rear suspension preload and decrease travel. To increase ski pressure the front rear scissor stop (FRSS) should be set to low. To decrease ski pressure the FRSS should be set to high.

To properly adjust the rear suspension, start with the lightest preload setting that will prevent heavy bottoming. Adjustments should be made to one area at a time, in order to properly evaluate the change.

NOTE: Rear spring settings will affect ski-to-ground pressure. If ski pressure is too light it may be desirable to tighten rear springs for an increase in ski-to-ground pressure. It is also possible to reposition the FRSS for increased ski pressure. See page 129.

Front Track Shock Spring

Front track shock spring preload is adjusted by grasping the spring and turning in a clockwise direction to increase the preload. Turn in a counterclockwise direction to decrease preload.

Rear Track Shock Spring

The rear track shock coil spring does not have a threaded adjuster. One option to decrease preload for less aggressive riders is removal of the rear track shock spring.

SUSPENSION

Front Rear Scissor Stop (FRSS)

The purpose of the front rear scissor stop (FRSS) is to control the bump attitude of the rear suspension. As the front torque arm (FTA) hits the bump, it forces the rear scissor to collapse a predetermined amount, depending on the FRSS block position.

This accomplishes two important things, it allows a lighter spring rate on the FTA because it can borrow spring rate from the rear torsion springs; and it prepares the rear portion of the suspension for the bump.

The FRSS is made of a resilient material allowing smooth action and preventing any suspension component damage.

This unique feature is applied to the Xtra-10 and Xtra-12 rear suspensions. Patents are pending.

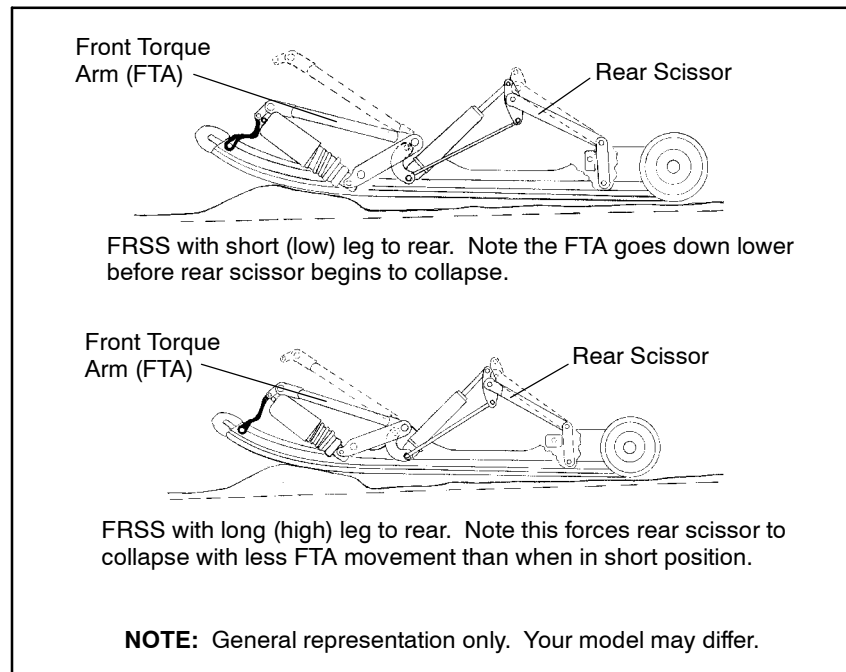

SUSPENSION

Front Rear Scissor Stop (FRSS)

To adjust the FRSS compress the rear portion of the rear suspension until the rear scissor pivots away from the FRSS. Turn adjuster to desired position. The dot on the stop indicates the high position. High position is with the dot located toward the rear of the machine. (See illustration) Medium position is with the dot toward the front of the machine. **CAUTION:** Be sure both blocks are in the same position or suspension damage may occur. **NOTE:** It may be necessary to loosen the FRSS mounting bolts to adjust the position. Retighten after adjustment.

If adjustment of the FRSS does not provide desired ski pressure, move the FRSS to the optional front hole. Remove the attaching bolts and relocate the FRSS block in the forwardmost hole. Reinstall bolts and tighten.

After moving the FRSS to the forwardmost hole, readjust the FRSS until desired ski pressure is obtained.

NOTE: The FRSS only controls ski pressure under steady state throttle positions or deceleration. The RRSS controls ski pressure under acceleration.

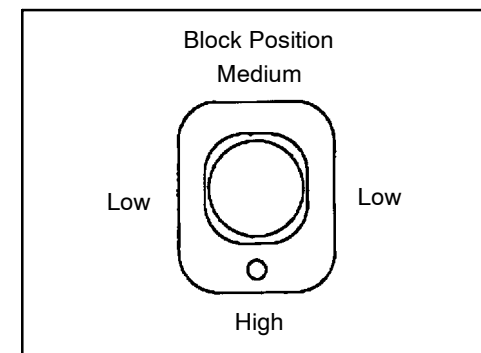
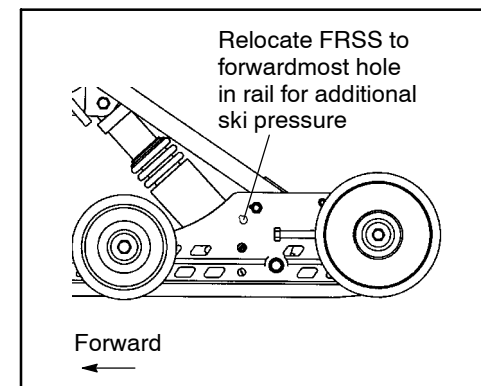
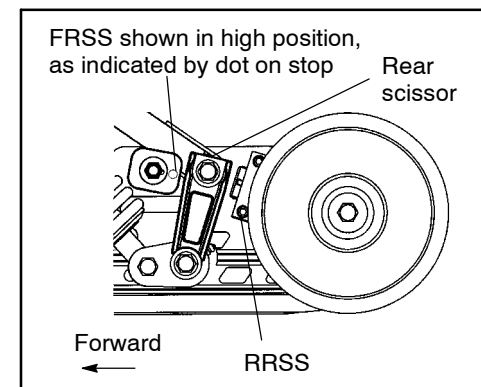

SUSPENSION

Xtra-12 Rear Rear Scissor Stop (RRSS)

The RRSS on Xtra-12 type suspensions is not adjustable.

Xtra-10 Rear Rear Scissor Stop (RRSS)

The RRSS controls weight transfer from the skis to the rear suspension. It also influences the stiffness of the ride by controlling the amount of coupling action between the front and rear torque arms. To increase the stiffness of the Xtra-10 rear suspension, the RRSS should be set in the high position, but weight transfer will be reduced under acceleration.

NOTE: On Xtra-10 models only the RRSS can be totally removed for maximum weight transfer. However, unless the torsion springs and rear shock valving are changed, the ride will be compromised.

Also, tensioning the front limiter strap can improve snow mobility in some snow conditions. See your dealer for more information.

When moving rear torque arm to lower mounting position (below tunnel), use dummy bolt in the hole where bolt was removed to secure rear suspension mounting pad. See your dealer for more information. (700 SKS only)

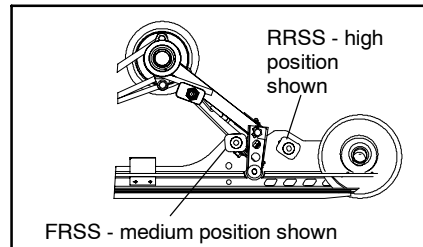
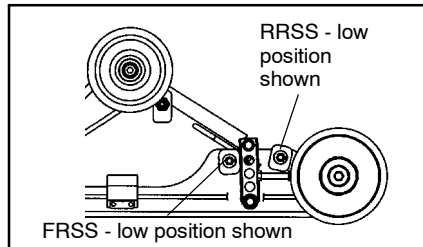

NOTE: Only available on 700 SKS

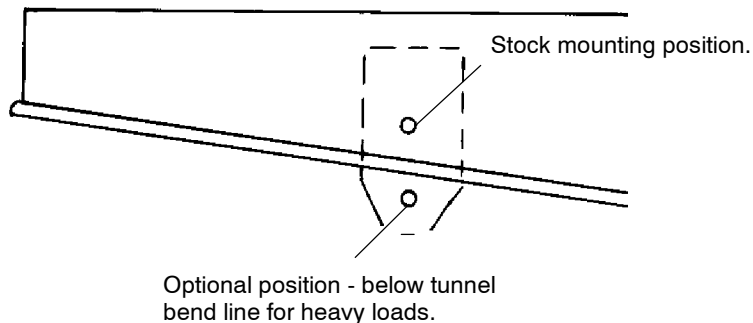

SUSPENSION

Torsion Spring Adjustment - Xtra-12 Type

Torsion spring preload is adjusted by turning the two position cam (A) on the short leg of the spring as shown with the engine spark plug tool. This adjustment is easier if the long spring leg is lifted over the roller and replaced after the cam is properly positioned.

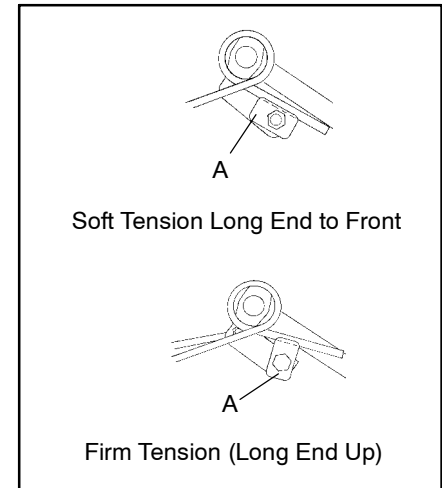

Torsion Spring Adjustment - Xtra-10 Type

Rear spring tension adjustments are made by rotating the eccentric spring block (A) as shown with the engine spark plug tool. The block provides three spring tension positions. This adjustment is easier if the long spring leg is lifted over the roller and replaced after the block is properly positioned.

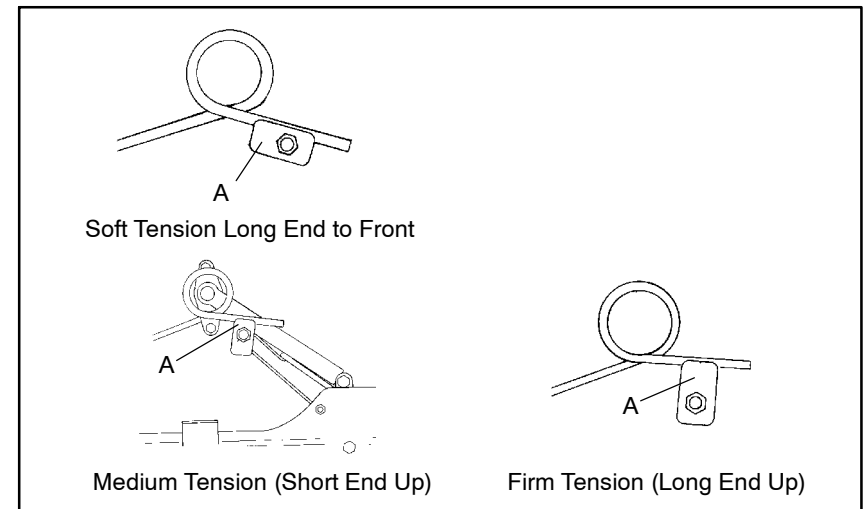

SUSPENSION

Suspension Performance Tips

Generally, rider weight determines the position at which the spring preload should be set. However, this may vary with riding style. With a little experimentation, each rider can find his or her best set-up. Remember, the adjustments are easy to make, involve very little time or effort, and greatly affect the ride.

New hi-fax will offer improved performance over worn hi-fax in deep snow.

It is always a good idea to install a hood screen whenever operating in deep snow. This will help keep the underhood area clean of snow and debris, and will prohibit ice build up.

Polaris offers track kits designed for improved flotation in deep snow. Your dealer can help you choose the correct kit for your machine.

When riding on ice or hard-packed snow, adding a set of bogie wheels to the rail may enhance the machine's performance. Bogie wheel kits are available from your dealer.

IMPORTANT: Keep the suspension pivot points lubricated. This will reduce moisture and rust build-up.

SUSPENSION COUPLING

On all Polaris snowmobile rear suspensions there are two torque arms that control the movement of the rail beam. Prior to the advent of "Suspension Coupling", these torque arms could move independently of each other. Rear suspension "coupling" links the movement of the front and rear torque arms to each other, much like an anti-roll bar links the left hand and right hand front suspension skis to each other. There are two types of rear suspension coupling.

REAR TO FRONT COUPLING AND THE REAR REAR SCISSOR STOP (RRSS)

The Rear Rear scissor Stop (RRSS) couples the movement of the rear torque arm to the front torque arm.

The RRSS limits the amount of independent movement between the rear torque and the front torque arm.

When landing on the rear of the suspension, the rear torque arm compresses. The RRSS links that movement to the front torque arm, causing it to compress, borrowing shock and spring damping from the front torque arm, reducing the possibility of bottoming out.

FRONT TO REAR COUPLING AND THE FRONT REAR SCISSOR STOP (FRSS)

The Front Rear Scissor Stop (FRSS) couples the movement of the front torque arm to the rear torque arm.

The FRSS limits the amount of independence between the movement of the front torque arm to the rear torque arm.

When hitting a bump, the front torque arm starts to compress. The FRSS links that movement to the rear torque arm, causing it to compress and raise the rear suspension up as one, only allowing the suspension to hit the bump once, eliminating kickback.

TRADEOFFS

All suspension designs involve a compromise or tradeoff. For example, a suspension set-up for snowcross racing applications would ride very stiff on the trail. A suspension set-up for trail riding would bottom out harshly on a snowcross course. The same compromise holds true for the scissor stop locations.

FRONT REAR SCISSOR STOP (FRSS) - ATTRIBUTES

Moving the FRSS to a higher position or rearward hole will have the following affects on the suspension:

- Slightly limit overall suspension travel.
- Snow mobility will be slightly reduced.
- Chatter bump ride will improve.
- Bottoming out of the front torque arm will be reduced.
- Secondary bump kick back will be reduced.

SUSPENSION

REAR REAR SCISSOR STOP (RRSS) - ATTRIBUTES

Moving the RRSS to a higher position or forward hole will have the following affects on the suspension:

- Weight transfer will be reduced.
- Chatter bump ride will improve.
- Bottoming of the rear torque arm will be reduced.
- Rear suspension action will become “stiffer.”

TROUBLESHOOTING

Suspension Troubleshooting - Models with X-12

Problem	Solution
Rear suspension bottoms too easily	<ul style="list-style-type: none"> -Check to be sure FRSS block is in highest position -Adjust torsion spring blocks to highest position -Adjust coil over spring on front track shock to increase preload -Change torsion springs to .421 diameter (on 121" models only) -Change to next heavier coil spring Turn indy select / AFX compression screw clockwise
Rides too stiff in rear	<ul style="list-style-type: none"> -Check for binding suspension shafts and grease all pivot points -Decrease spring preload adjustments -Remove rear track shock spring or reduce rate of spring (refer to wallchart) -Change front track shock to lighter spring -Change to lighter shock valving on models equipped with Indy Select shocks (refer to wallchart) -Adjust front track shock spring to less preload. -Change FRSS to lowest position.
Machine darts from side to side	<ul style="list-style-type: none"> -Make sure skis are aligned properly -Make sure spindles and all steering components are free turning -Make sure skags are straight on skis -Ensure use of "Easy-Steer" skags -Shift FRSS to highest position
Front end pushes	<ul style="list-style-type: none"> -Check for worn skags -Check for binding suspension shafts and grease all pivot points -Increase front IFS preload -Change FRSS to low setting or move to forwardmost hole
Steering is heavy	<ul style="list-style-type: none"> -Check ski alignment -Check skags and skis for damage -Change FRSS to high setting -Decrease IFS spring preload
Setting up for deep snow operation	<ul style="list-style-type: none"> -Rotate FRSS to lowest setting, depending upon rider preference -Decrease preload on front track spring -Move FRSS to forwardmost hole -Tighten limiter strap one hole

TROUBLESHOOTING

Suspension Troubleshooting - Models with X-12, 133"

Problem	Solution
Rear suspension bottoms too easily	<ul style="list-style-type: none"> -Check to be sure FRSS block is in highest position -Adjust torsion spring blocks to highest position -Adjust coil over spring on front track shock to increase preload, replace front track spring with overload kit #2871439 -Change to stiffer shock valving on Indy Select front track shock
Rides too stiff in rear	<ul style="list-style-type: none"> -Check for binding suspension shafts and grease all pivot points -Decrease spring preload adjustments -Remove rear track shock spring or reduce rate of spring (refer to wallchart) -Change front track shock to lighter spring -Change to lighter shock valving on Indy Select shocks
Machine darts from side to side	<ul style="list-style-type: none"> -Make sure skis are aligned properly -Make sure spindles and all steering components are free turning -Make sure skags are straight on skis
Front end pushes	<ul style="list-style-type: none"> -Check for worn skags -Check for binding suspension shafts and grease all pivot points -Increase front IFS preload -Move FRSS to low position or move to forward hole
Steering is heavy	<ul style="list-style-type: none"> -Check ski alignment -Check skags and skis for damage -Decrease IFS spring preload
Setting up for deep snow operation	<ul style="list-style-type: none"> -Rotate FRSS to lowest setting, depending upon rider preference -Decrease preload on front track spring -Tighten limiter strap one hole

TROUBLESHOOTING

Suspension Troubleshooting - Models with X-10

Problem	Solution
Rear suspension bottoms too easily	<ul style="list-style-type: none"> -Increase torsion spring preload -Increase rear shock compression valving by turning screw clockwise (if equipped with optional Indy Select shock) -Change to heavier valving (if equipped with Fox™ shocks) -Increase torsion spring wire diameter
Rides too stiff in rear	<ul style="list-style-type: none"> -Check for binding suspension shafts and grease all pivot points -Decrease torsion spring preload adjustments -Decrease rear shock compression valving by turning screw counterclockwise (if equipped with optional Indy Select shock) -Change to lighter valving if (if equipped with Fox™ shocks) -Check for proper track tension
Machine darts from side to side	<ul style="list-style-type: none"> -Make sure skis are aligned properly -Make sure spindles and all steering components are free turning -Make sure skags are straight on skis -Check hi-fax and replace if worn -Reduce ski pressure: <ul style="list-style-type: none"> ●Increase front track spring preload ●Reduce IFS spring preload by adjusting cam or threaded adjuster ●Reduce rear torsion spring preload
Front end pushes	<ul style="list-style-type: none"> -Check for worn skags -Check for binding suspension shafts and grease all pivot points -Increase IFS spring preload by adjusting cam or threaded adjuster -Decrease front limiter strap length
Steering is heavy	<ul style="list-style-type: none"> -Check ski alignment -Check skags and skis for damage -Reduce ski pressure: <ul style="list-style-type: none"> ●Increase front track spring preload ●Reduce IFS spring preload by adjusting cam ●Reduce rear torsion spring preload
Setting up for deep snow operation	<ul style="list-style-type: none"> -Change worn hi-fax -Move front track shock assembly to upper position

TROUBLESHOOTING

Suspension Troubleshooting - Models with X-10

Problem	Probable Cause	Solution
Harsh drive clutch engagement	Drive belt worn or too narrow	Replace.
	Excessive belt/sheave clearance	CONTACT YOUR DEALER.
Drive belt turns over	Wrong belt for application	Replace.
	Clutch alignment out of spec	Adjust alignment offset.
	Engine mount broken or loose	Inspect/adjust or replace. CONTACT YOUR DEALER.

TROUBLESHOOTING

Belt Wear/Burn

Belt Wear/Burn Diagnosis	
Belt Burning: Causes	Solutions
Driving at low RPM	Drive at higher RPMs. Gear the machine down. Check belt deflection.
Insufficient warm-up	Warm engine at least 5 minutes. Take drive-belt off the machine in extremely cold weather, and warm it up. Break machine loose from the snow.
Towing at low RPM	Do not tow in deep snow. Use fast, aggressive throttle to engage clutch.
Riding with high RPM and slow speed (8000 RPM/10 MPH)	Lower the gear ratio. Remove windage plates from the clutch. Reduce RPM. Avoid riding in high ambient temperatures.
Ice & snow build-up between track and tunnel	Allow for a long warm-up. Warm belt sufficiently. Fast, effective use of throttle for efficient engagement. Break machine loose.
Poor running engine	Check for carb and choke synchronization fouled plugs, debris in the carbs, water, ice or dirt in gas tank or fuel line.
Loading machines onto trailers	Skis may gouge into trailers and prevent the drivetrain from spinning properly. Use enough speed to drive machine completely onto trailer. If not, push or pull machine to finish loading.
Clutch malfunction	Inspect clutch components. Contact dealer.
Slow, easy clutch engagement	Fast, effective use of throttle for efficient engagement.

TROUBLESHOOTING

Engine Troubleshooting

CAUTION: Unless you have experience and training in two-cycle engine repair, see your dealer if technical problems arise.

Problem	Probable Cause	Solution
Erratic engine operating RPM during acceleration or load variations	Drive clutch binding	a. Disassembly of drive clutch required to inspect shift weights for wear and free operation. CONTACT YOUR DEALER. b. Clean and polish stationary shaft hub.
	Driven clutch malfunction	a. Replace ramp buttons. CONTACT YOUR DEALER. b. Inspect movable for excessive bushing clearance/replace. CONTACT YOUR DEALER.
Machine fails to move	Transmission in Neutral	Shift
	Clutch jammed	Belt twisted, spring broken, weights stuck, lubricated, CONTACT YOUR DEALER.
	Track jammed	a. Foreign object caught or hi-fax melted to track clips due to lack of proper lubrication. b. Machine may be frozen to ground. Track may be iced up.
Noise in drive system	Chaincase sprocket or chain jammed or broken	Chain is loose or broken, chain tightener is loose. CONTACT YOUR DEALER.
	Broken drive clutch components	CONTACT YOUR DEALER.
	Bearing failure/ chaincase, jackshaft, or front drive shaft	CONTACT YOUR DEALER.
	Drive belt surface flat spots	Inspect/adjust or replace.
Poor low RPM performance	Drive chain loose or worn, sprocket teeth broken	Inspect/replace.
	Worn drive belt	Inspect/replace.
	Excessive belt/sheave clearance	CONTACT YOUR DEALER.
	Loose torque stop	Inspect/adjust.
Engine does not start (electric start models)	Sticky clutch	CONTACT YOUR DEALER.
	Wire connections	CONTACT YOUR DEALER.

TROUBLESHOOTING

Engine Troubleshooting

Problem	Probable Cause	Solution
Engine does not turn	Seized engine Hydrostatic lock (fuel has entered crankcase while vehicle was standing or being transported)	CONTACT YOUR DEALER. Seizure is a result of poor lubrication, inadequate fuel supply, broken parts, or improper cooling. CONTACT YOUR DEALER to correct cause. Drain plug(s) located on lower crankcase for emergency draining.
Engine turns but fails to start	Faulty ignition No fuel to engine Flooded engine (normal situation caused by too much choking) Poor engine compression	Remove spark plug(s) and replace with new plug(s). If engine still fails to start, check for spark; if no spark CONTACT YOUR DEALER. a. Check tank level and fill up with correct fuel. b. Ice in fuel line, filter, or pump. On the standard Polaris carburetor, the choke will not function with the throttle depressed. See second item under "Probable Cause" of "Engine continually backfires". Hold throttle open, crank engine several times (may be necessary to change plug(s), however, the plug(s) may operate satisfactorily when dried). Running too lean a mixture (too small a main jet will cause seizure resulting in loss of power). CONTACT YOUR DEALER. This indicates a major engine problem which must be repaired before engine is run.
Engine lacks power	Fouled or defective spark plug Fuel filter (loss of high RPM power) Incorrect clutching Carburetor and fuel pump	Change and test operation. Check fuel filter flow. Disconnect hose and drain about 1/2 cup. Fuel flow should be steady and encompass the entire diameter of fuel line. If not, replace filter. CONTACT YOUR DEALER. There is no adjustment to change power output. CONTACT YOUR DEALER.
Engine continually backfires	Faulty plug(s) Carburetor	Change plug(s) Dirt or ice in fuel system. (Deicer should be added to fuel at all times for assurance against fuel line icing.
Engine requires more than normal pulls to start	Poor gasoline Not enough fuel getting to engine	Replace with "fresh" winter fuel. Refer to page NO TAG for primer instructions

ACCESSORIES

Accessories

There are a wide range of accessories available for Polaris snowmobiles. From Map Lights to electric start, Polaris has the accessories that will make your ride even **more** pleasurable. Contact your dealer for a list of accessories available for your machine.

NOTE: *Accessory tether switch available for all models - PN 2870668.*

WARNING: You must only use Polaris parts and accessories on your 2000 Polaris snowmobile. Use of non-Polaris approved parts and accessories may result in the following:

- Non-compliance with requirements
- Voiding warranty
- Personal injury to yourself or others

This applies but is not limited to the following areas: Brakes, clutches, fuel systems, and exhaust systems.

NOTE: Exhaust systems are critical safety areas and must use approved Polaris parts. Please see your Polaris dealer for service.

Maintenance Items

Battery Tender	2871076
Gas Dock	2871254
Nylon Starter Rope (100' spool)	2870621
Recoil Starter Handle	2870500
Fuel Filters (Pkg of 2)	2870622
Drive Belt Holders (Pkg of 2)	2870502
Tool Pouch	2870527
Tool Kit	2870463
Carbon Clean	2871326
Pump for Chaincase Oil Gallon	2870465
Chaincase Oil - Gallon	2870464
Chaincase Oil - 16 oz.	2871280
Brake Fluid DOT 3, 12 oz.	2870990
Clutch Lube 4 oz.	2870510
Grease, Premium All Season	2871066
Anti-Corrosive Lubricant/Electrical Connector Lubricant	2871329
Fuel Deicer, Isopropyl	2870505
Fuel Stabilizer, 16 oz.	2870652
Fogging Oil	2870791
T-9 Metal Protectant	2871064
Metal Polish	2870632
Grease Gun Kit (All Season) 3 oz.	2871312
Refill Grease Cartridge (All Season) 3 oz.	2871322

Paint Codes

Paint codes are found in your Owner's Manual Supplement. Paints can be ordered direct from Midwest Industrial Coatings (612-934-8252). Mix as directed.

SERVICE AND WARRANTY INFORMATION

Polaris Anti-Theft System

The Polaris anti-theft system monitoring program (PATS) is designed to aid owners of registered snowmobiles in recovery of their machines, if stolen.

Administration

- 1. Polaris snowmobile owner reports theft.
 - A. In addition to notifying the proper law enforcement officials, the owner must call the Polaris warranty department in the United States and Canada.
 - US #612-542-0500
 - Canada #204-925-7100
 - B. Owners must provide their name, address, telephone number and model and serial number of stolen machines.
- 2. Polaris warranty will provide all dealerships with a monthly updated list of all stolen units, to further monitor thefts.
- 3. Polaris warranty will aid in notification of recovered units to their proper owner.

Obtaining Service and Warranty Assistance

Read carefully and understand the service data and the Polaris Warranty contained in this manual. Contact your Polaris dealer in matters pertaining to replacement parts, service or warranty. He is constantly kept up to date on changes, modifications and tips on snowmobile maintenance, which may supersede information contained in this manual. He is familiar with our policies and procedures and will be happy to assist you.

When writing about parts, service or warranty, always include the following information:

- 1. Serial number
- 2. Model number
- 3. Dealer name
- 4. Date of purchase
- 5. Details of trouble experienced
- 6. Length of time and conditions of operation
- 7. Indicate previous correspondence

Use the following space to record the model and serial numbers of your machine and engine.

Machine Model No. _____

Machine Serial No. _____

Engine Model No. _____

Engine Serial No. _____

WARRANTY

LIMITED WARRANTY

Polaris Industries Inc., 1225 Highway 169 North, Minneapolis, Minnesota 55441-5078, gives a ONE YEAR LIMITED WARRANTY on all components of the Polaris snowmobile against defects in material or workmanship. This warranty covers the parts and labor charges for repair or replacement of defective parts which are covered by this warranty. This warranty begins on the date of purchase. This warranty is transferrable to another consumer during the warranty period through a Polaris dealer. There is a charge of \$35.00 payable to Polaris Industries Inc.

REGISTRATION

At the time of sale, the Warranty Registration Form must be completed by your dealer and submitted to Polaris within ten days. Upon receipt of this registration, Polaris will record the registration for warranty. No verification of registration will be sent to the purchaser as the copy of the Warranty Registration Form will be the warranty entitlement. If you have not signed the original registration and received the "customer copy", please contact your dealer immediately. NO WARRANTY COVERAGE WILL BE ALLOWED UNLESS YOUR SNOWMOBILE IS REGISTERED WITH POLARIS.

Initial dealer preparation and set-up of your snowmobile is very important in ensuring trouble-free operation. Purchasing a machine in the crate or without proper dealer set-up will void your warranty coverage.

WARRANTY COVERAGE AND EXCLUSIONS:

LIMITATIONS OF WARRANTIES AND REMEDIES

The warranty excludes any failures that are not caused by a defect in material or workmanship. This warranty does not cover accidental damage, normal wear and tear, abuse or improper handling. This warranty also does not cover any snowmobile that has been altered structurally, neglected, improperly maintained, used for racing, or used for purposes other than for which it was manufactured, or for any damages which occur during trailer transit or as a result of unauthorized service or the use of unauthorized parts. In addition, this warranty does not cover physical damage to paint or finish, stress cracks, tearing or puncturing of upholstery material, corrosion, or defects in parts, components or snowmobile due to fire, explosions or any other cause beyond Polaris' control.

This warranty does not cover the use of unauthorized lubricants, chemicals, or fuels that are not compatible with the snowmobile.

The exclusive remedy for breach of this warranty shall be, at Polaris' exclusive option, repair or replacement of any defective materials, or components or products. THE REMEDIES SET FORTH IN THIS WARRANTY ARE THE ONLY REMEDIES AVAILABLE TO ANY PERSON FOR BREACH OF THIS WARRANTY. POLARIS SHALL HAVE NO LIABILITY TO ANY PERSON FOR INCIDENTAL, CONSEQUENTIAL OR SPECIAL DAMAGES OF ANY DESCRIPTION, WHETHER ARISING OUT OF EXPRESS OR IMPLIED WARRANTY OR ANY OTHER CONTRACT, NEGLIGENCE, OR OTHER TORT OR OTHERWISE. Some states do not permit the exclusion or limitation of incidental or consequential damages or implied warranties, so the above limitations or exclusions may not apply to you if inconsistent with controlling state law.

WARRANTY

ALL IMPLIED WARRANTIES (INCLUDING BUT NOT LIMITED TO THE IMPLIED WARRANTIES OF MERCHANTABILITY AND FITNESS FOR A PARTICULAR PURPOSE) ARE LIMITED IN DURATION TO THE ABOVE ONE YEAR WARRANTY PERIOD. POLARIS FURTHER DISCLAIMS ALL EXPRESS WARRANTIES NOT STATED IN THIS WARRANTY. Some states do not allow limitations on how long an implied warranty lasts, so the above limitation may not apply to you if inconsistent with controlling state law.

HOW TO OBTAIN WARRANTY SERVICE

If your snowmobile requires warranty service, you must take it to a Polaris dealer authorized to repair Polaris snowmobiles. When requesting warranty service you must present your copy of the Warranty Registration form to the dealer. (THE COST OF TRANSPORTATION TO AND FROM THE DEALER IS YOUR RESPONSIBILITY). Polaris suggests that you use your original selling dealer; however, you may use any Polaris Servicing Dealer to perform warranty service.

Please work with your dealer to resolve any warranty issues. Should your dealer require any additional assistance they will contact the appropriate person at Polaris.

This warranty also gives you specific legal rights, and you may also have other rights which vary from state to state.

If any of the above terms are void because of state or federal law, all other warranty terms will remain in effect.

Engine Oil

1. Always use Polaris engine oil.
2. Never substitute or mix oil brands as serious engine damage and voiding of warranty can result.

WARRANTY

Polaris Extended Service Contract

Polaris now is offering an extended engine service contract which provides the following benefits:

- Additional engine protection beyond the original twelve month warranty.
- Backed by the strength of Polaris - no third party involvement.
- Repairs use only genuine top quality Polaris parts.
- Peace of mind. The Polaris Extended Service Contract is honored by all authorized Polaris snowmobile dealers in North America. However, where possible we urge you to contact the selling dealer. There are no cards for you to carry as repair authorization for your dealer is only a phone call away.
- Because the extended service contract is transferable for a \$35.00 fee, the snowmobile's resale value is increased.
- The Polaris Extended Service Contract is very affordable and can be financed with the Polaris Star Card.

Conditions:

- The Polaris Extended Service Contract must be purchased within 90 days from the date of the unit's registration.
- Each repair visit is subject to a \$50.00 deductible.
- The Extended Service Contract applies to the first 5000 miles or two calendar years from date of registration, whichever comes first. Tampering with the odometer shall void the Extended Service Contract. No extensions to coverage under the Extended Service Contract will be given.
- Snowmobiles used in commercial purposes or for racing are excluded from coverage.

Coverage:

Second year coverage is extended to 1997 and 1998 model engine failures due to defects in material and workmanship as determined by Polaris in its sole discretion. Used snowmobiles are not eligible under this program. A partial list of items excluded from coverage includes:

- Damage due to accident, fire, explosion, theft, or other causes beyond Polaris' control.
- Damage caused by the failure of other components of the snowmobile.
- Failures caused by improper fuel or oil.
- Failures caused due to improper adjustments, including but not limited to carburetor jetting and clutching.
- Failure due to unauthorized service.
- Failures due to lack of service as required in the Owner's Manual or Polaris updates. This includes off season storage as listed in the Owner's Manual.
- Failure due to unauthorized parts or modifications.
- Normal wear parts, including but not limited to: spark plugs, hoses, batteries, controls, and recoil ropes are excluded from coverage. Gaskets are covered as are intake and exhaust manifolds excluding paint coverage.
- Electrical coverage is limited to the CD and ECU box, coils, stator plate, and sensors. Wiring and other electrical components are excluded from coverage.

Polaris Extended Service Contract

Coverage, Cont.:

- Oil injection system coverage is limited to the control module, sensors, solenoids, pump, and throttle cable switch.
- Cooling system coverage is limited to the water pump assembly and components, fan, fan bearings, temperature sensor, gasket and seals.
- Non-wear related carburetor parts are covered. Carburetor jetting and adjustments are excluded from coverage. The fuel pump and choke are covered.
- Clutches and related clutch parts, including but not limited to, the drive belt are excluded from coverage.
- Electrical components are excluded from coverage.
- The gearcase and transmission are excluded from coverage.

Polaris acknowledges the following products mentioned in this manual:

Loctite, Registered Trademark of the Loctite Corporation

STA-BIL, Registered Trademark of Gold Eagle

FOX, Registered Trademark of Fox Shox

Hi-Fax, Trademark of Himont Advanced Materials

Hooker Stud, Registered Trademark of Woody's International Engineering and Manufacturing, Inc.

INDEX

Accessories	142	Identification and Specifications	26-30
Air Intake System	54-55	IFS Adjustment	108-109
Auxiliary Shut Off	29	Indy Select Shock, 110	124-125
Auxiliary Shut Off Switch	40	Installing the Side Bulbs	77
Backrest Adjustment	79	Limiter Strap Adjustment	126
Battery	45-47	Low Oil Indicator Light	32
Battery Connections	45	Lubricant, Premium 2-Cycle	32
Battery Fluid	45	Lubrication	52
Battery Installation	47	Maintenance	48-105
Battery Removal	46	Maintenance Check, Weekly	48
Belt Deflection Adjustment	82	Maintenance Inspection, 150 Mile	49-51
Belt/Wear Burn	139	Maintenance Inspection, 1000 Mile	49-51
Bleeding Cooling System	65-66	Maintenance Inspection, 2000 Mile	49-51
Bleeding the Cooling System, RXL Touring	65-66	Oil Filter	60
Brake Adjustment	72-73	Oil Injection System	32
Brake Bleeding	71	Operation	31-44
Brake Fluid Replenishment	70	Operation Warnings	10-24
Brake Inspection	69, 74	Owner Maintenance Program	48
Brake Lever Travel	13, 69, 73	Oxygenated Fuels	35
Carburetor Adjustments	61-62	Paint Codes	142
Carburetor Protection	63	Park Brake	14
Chaincase Oil Level	67-68	Pre-Ride Warm Up	43
Choke and Cable Lubrication	66	Pre-Start Check	38
Clutch Alignment and Offset	81	Preservation of the Environment	25
Clutch Center Distance	82	Rear Rear Scissor Stop (RRSS)	130
Clutch System	81	Rear Suspension Adjustments	127
Controls and Instruments, 500 EFI SKS	29	Rear Suspension, WT, Transport	121-122
Coolant	64	Rear Suspension, X10	112-113
Coolant Level	64	Rear Suspension, X12	116-117
Cooling System, Bleeding	65-66	Rear Suspension, X-Lite	119-120
Daily Storage	44	Rear Torsion Spring	131
Drive Belt Installation	80	Rear Track Shock Spring	127
Drive Belt Removal	80	Removing the Side Bulbs	77
Drive Chain Tension	67	Reserve Capacity	36
Drive System	31	Reverse Kit Maintenance	83
Emergency Starting	42	Reverse Operation	84
Emergency Stopping Procedure	42	Safety Alert	1-2
Engine Break In	37	Safety Warning and Operation Decals	2-9
Engine Cooling	64	Scissor Stop	128-130
Engine Shut Off Switch	29	Sediment Trap Service	59
Engine Troubleshooting	140-141	Service and Warranty Information	143
Exhaust System	63	Skag Replacement	100
Extended Storage	85	Ski Skags	100
Flushing the Cooling System	64	Spark Plug Removal	57
Front Rear Scissor Stop (FRSS)	129	Spark Plug Selection	56
Front Track Shock Spring	127	Spring Tension, Rear	131
Fuel System Deicers	36	Starting a Cold Engine	38
Greasing Couplers	53	Starting a Warm Engine	39
Greasing Driveshaft Bearing	53	Steering Inspection and Adjustment	98
Greasing Jackshaft Bearing	53	Steering System	98
Handlebar Adjustment	78	Storage	85-86
Headlight Adjustment	75	Suspension	106-134
Headlight Bulb Installation	76	Suspension Adjustment, X-Lite/WT	123
Headlight Bulb Removal	76	Suspension Adjustment, X10	114
Hi-Fax Wear	101	Suspension Adjustment, X12	118
High Temperature Indicator Light	64	Suspension Adjustment Features	114, 118
		Suspension Components	107
		112-113	

INDEX

Suspension Lubrication	103-105	Track Lubrication	95
Suspension Maintenance	101	Track Studding	96
Suspension Performance Tips	132	Track Tension	89-91
Suspension Set Up, Rear	127	Track Warm Up	93
Suspension Troubleshooting	135-138	Traction Products	95
Tailight Bulb Replacement	77	Transporting	87
Throttle Cable Lubrication	66	Troubleshooting	135-141
Throttle Safety Switch	40	Tune Up	88
Tool Kit	88	Understanding Warnings	1
Tool Pouch Clip	36	Vehicle Nomenclature	26-28
Torque Stop	83	Warranty	144-147
Torsion Spring Adjustment	131	Water Trap Service	59
Towing	44, 88	Wear Strips	97
Track Alignment	92	Windchill/Temperature Charts	19
Track Inspection	94		