



**POLARIS®**

**RZR®**

**2020**  
**OWNER'S MANUAL**

**RZR PRO XP**  
**RZR PRO XP 4**



## **WARNING**

Read, understand, and follow all of the instructions and safety precautions in this manual and on all product labels.

Failure to follow the safety precautions could result in serious injury or death.



## **WARNING**

Operating, servicing, and maintaining a passenger vehicle or off-road vehicle can expose you to chemicals including engine exhaust, carbon monoxide, phthalates, and lead, which are known to the State of California to cause cancer and birth defects or other reproductive harm. To minimize exposure, avoid breathing exhaust, do not idle the engine except as necessary, service your vehicle in a well-ventilated area and wear gloves or wash your hands frequently when servicing your vehicle.

For more information go to [www.P65Warnings.ca.gov/passenger-vehicle](http://www.P65Warnings.ca.gov/passenger-vehicle).



*For videos and more information about a safe riding experience with your Polaris vehicle, scan this QR code with your smartphone.*



**POLARIS**<sup>®</sup>



2020 RZR Owner's Manual

**ProXP**  
**ProXP 4**

POLARIS® and RZR® are trademarks of POLARIS Industries Inc.

Copyright 2019 Polaris Industries Inc. All information contained within this publication is based on the latest product information at the time of publication. Due to constant improvements in the design and quality of production components, some minor discrepancies may result between the actual vehicle and the information presented in this publication. Depictions and/or procedures in this publication are intended for reference use only. No liability can be accepted for omissions or inaccuracies. Any reprinting or reuse of the depictions and/or procedures contained within, whether whole or in part, is expressly prohibited.

The original instructions for this vehicle are in English. Other languages are provided as translations of the original instructions.

Printed in U.S.A.

9929980



Thank you for purchasing a POLARIS vehicle, and welcome to our world-wide family of POLARIS enthusiasts. Be sure to visit us online at [www.polaris.com](http://www.polaris.com) for the latest news, new product introductions, upcoming events, career opportunities and more.

Here at POLARIS we proudly produce an exciting line of utility and recreational products. We believe POLARIS sets a standard of excellence for all utility and recreational vehicles manufactured in the world today. Many years of experience have gone into the engineering, design, and development of your POLARIS vehicle, making it the finest machine we've ever produced.

- Snowmobiles
- SPORTSMAN® All-terrain vehicles
- Low emission vehicles (LEVs)
- *RANGER*® utility vehicles
- POLARIS® PRO XD™ work vehicles
- SLINGSHOT® three wheel motorcycles
- RZR® sport vehicles
- GEM® vehicles
- INDIAN® motorcycles
- POLARIS POWER® generators
- POLARIS DEFENSE® combat vehicles
- Timbersled® Snow Bikes

For safe and enjoyable operation of your vehicle, be sure to follow the instructions and recommendations in this owner's manual. Your manual contains instructions for minor maintenance, but information about major repairs is outlined in the POLARIS Service Manual and can be performed by a factory certified Master Service Dealer® (MSD) technician.

Your POLARIS dealer knows your vehicle best and is interested in your total satisfaction. Your POLARIS dealership can perform all of your service needs during, and after, the warranty period.

## SAFETY SYMBOLS AND SIGNAL WORDS

---

The following signal words and symbols appear throughout this manual and on your vehicle. Your safety is involved when these words and symbols are used. Become familiar with their meanings before reading the manual.

### DANGER

DANGER indicates a hazardous situation which, if not avoided, WILL result in death or serious injury.

### WARNING

SAFETY ALERT WARNING indicates a hazardous situation which, if not avoided, COULD result in serious injury or death.

### CAUTION

SAFETY ALERT CAUTION indicates a hazardous situation which, if not avoided, COULD result in minor to moderate injury.

### CAUTION

CAUTION indicates special precautions that must be taken to avoid vehicle damage or property damage.

### IMPORTANT

IMPORTANT provides key reminders during disassembly, assembly, and inspection of components.

### NOTICE

NOTICE provides key information by clarifying instructions.



The Prohibition Safety Sign indicates an action NOT to take in order to avoid a hazard.



The Mandatory Action Sign indicates an action that NEEDS to be taken to avoid a hazard.

## TABLE OF CONTENTS

---

<b>Introduction . . . . .</b>	<b>7</b>
<b>Safety . . . . .</b>	<b>9</b>
<b>Features and Controls . . . . .</b>	<b>31</b>
<b>Operation . . . . .</b>	<b>79</b>
<b>Winch Guide. . . . .</b>	<b>101</b>
<b>Emission Control Systems . . . . .</b>	<b>113</b>
<b>Maintenance . . . . .</b>	<b>115</b>
<b>Specifications . . . . .</b>	<b>195</b>
<b>Polaris Products . . . . .</b>	<b>201</b>
<b>Troubleshooting . . . . .</b>	<b>203</b>
<b>Warranty . . . . .</b>	<b>211</b>
<b>Maintenance Log . . . . .</b>	<b>221</b>





# INTRODUCTION

## BEFORE YOU RIDE

 **WARNING**

Failure to heed the warnings and safety precautions contained in this manual can result in severe injury or death. Your POLARIS vehicle is not a toy and can be hazardous to operate. This vehicle handles differently than cars, trucks or other off-road vehicles. A collision or rollover can occur quickly, even during routine maneuvers like turning, or driving on hills or over obstacles, if you fail to take proper precautions.

- Read this owner's manual and review the safety DVD that came with your vehicle. A free extra copy of the DVD can be obtained by contacting your local POLARIS dealer. Understand all safety warnings, precautions and operating procedures before operating the vehicle. Keep this manual with the vehicle.
- This vehicle is an **ADULT VEHICLE ONLY**. You **MUST** be at least age 16 and have a valid driver's license to operate this vehicle.
- All riders must be able to sit with backs against the seat, both feet flat on the floor and both hands on the steering wheel (if driving) or on a passenger hand hold.
- Always use the cab nets (or doors) while riding in this vehicle. Always keep hands, feet and all other body parts inside the vehicle at all times.
- Always wear a seat belt when riding in this vehicle. Always wear a helmet, eye protection, gloves, long-sleeve shirt, long pants and over-the-ankle boots.
- Never use this vehicle with drugs or alcohol, as these conditions impair judgment and reduce operator reaction time.
- Complete the steps described in the New Operator Driving Procedures section. Never allow a guest to operate this vehicle until the guest has completed the New Operator Driving Procedures.

## INTRODUCTION

### VEHICLE IDENTIFICATION NUMBERS

Record your vehicle's identification number ①, engine serial number ②, and key number ③ in the spaces provided. Remove the spare key and store it in a safe place. An ignition key can be duplicated only by ordering a POLARIS key blank (using your key number) and mating it with one of your existing keys. The ignition switch must be replaced if all keys are lost.

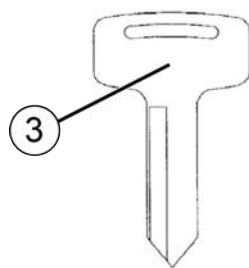
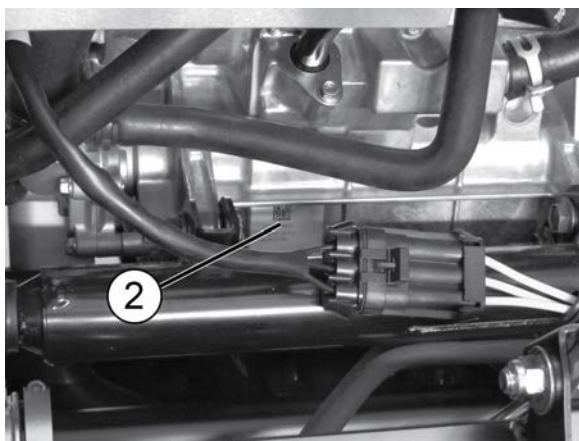
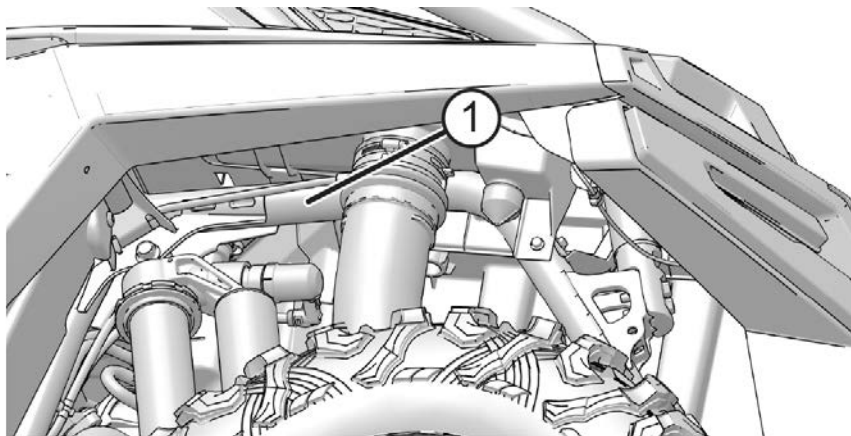

Vehicle Model Number:	
Vehicle Identification Number:	
Engine Serial Number:	
Key Number:	

## SAFETY

### SAFETY TRAINING

Safety training is a top priority for POLARIS. POLARIS strongly encourages you and any family members who will be riding this vehicle to take a training course

ROHVA (Recreational Off-Highway Vehicle Association) provides both an online safety e-course and a hands-on safety course. To access this valuable training, visit [www.rohva.org](http://www.rohva.org).

Your POLARIS vehicle is considered an off-road vehicle. Familiarize yourself with all laws and regulations concerning the operation of this vehicle in your area.

We strongly advise you to strictly follow the recommended maintenance program outlined in your owner's manual. This preventive maintenance program is designed to ensure that all critical components on your vehicle are thoroughly inspected at specific intervals.

**For more information about recreational off-road vehicle safety in the United States, visit [www.rohva.org](http://www.rohva.org) or call POLARIS at 1-800-342-3764.**

## SAFETY

---

### SAFE RIDING GEAR

The driver and all passengers must wear helmet ①, eye protection ②, long-sleeve shirt ③, gloves ④, long pants ⑤, over-the-ankle boots ⑥, and seat belt at all times. Protective gear reduces the chance of injury.



### HELMET

Wearing a helmet can prevent a severe head injury. Whenever riding this POLARIS vehicle, always wear a helmet that meets or exceeds established safety standards.

Approved helmets in the USA and Canada bear a U.S. Department of Transportation (DOT) label.

Approved helmets in Europe, Asia and Oceania bear the ECE 22.05 label. The ECE mark consists of a circle surrounding the letter E, followed by the distinguishing number of the country which has granted approval. The approval number and serial number will also be displayed on the label.

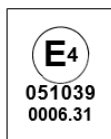

### EYE PROTECTION

Do not depend on eyeglasses or sunglasses for eye protection. Whenever riding this POLARIS vehicle, always wear shatterproof goggles or use a shatterproof helmet face shield. POLARIS recommends wearing approved Personal Protective Equipment (PPE) bearing markings such as VESC 8, V-8, Z87.1, or CE. Make sure protective eye wear is kept clean.

### GLOVES

Wear gloves for comfort and for protection from sun, cold weather and other elements.

## **BOOTS**

Wear sturdy over-the-ankle boots for support and protection. Never ride a POLARIS vehicle with bare feet or sandals.

## **CLOTHING**

Wear long sleeves and long pants to protect arms and legs.

## **RIDER COMFORT**

Under certain operating conditions, heat generated by the engine and exhaust system can elevate temperatures in the driver and passenger cab area. The condition occurs most frequently when a vehicle is being operated in high ambient temperatures at low speeds and/or high load conditions for an extended period of time. The use of certain windshield, roof and/or cab systems may contribute to this condition by restricting airflow. Any discomfort due to heat buildup in this area can be minimized by wearing proper riding apparel and by varying speeds to increase airflow.

## SAFETY

---

### SAFETY LABELS AND LOCATIONS

Warning labels ① have been placed on the vehicle for your protection. Read and follow the instructions of the labels on the vehicle carefully. If any of the labels depicted in this manual differ from the labels on your vehicle, always read and follow the instructions of the labels on the vehicle

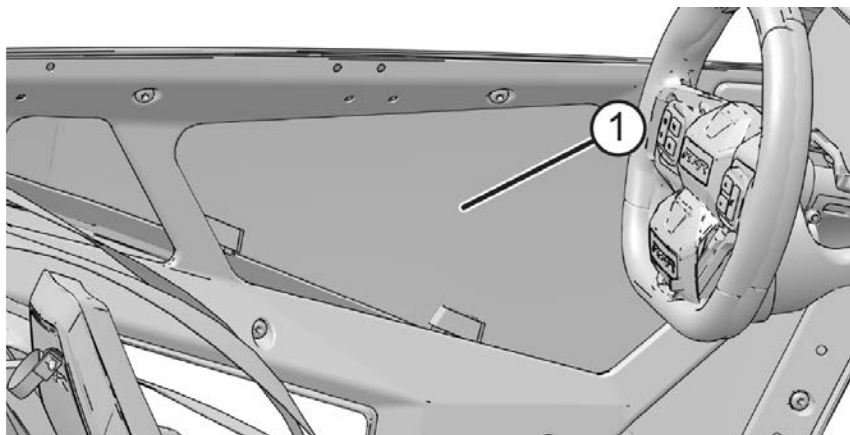

If an informational or graphic label becomes illegible or comes off, contact your POLARIS dealer to purchase a replacement. Replacement safety labels are provided by POLARIS at no charge. The part number is printed on the label.

### PROPER USE WARNING

#### WARNING:

Require Proper Use of Your Vehicle

Do your part to prevent injuries:

- Do not allow careless or reckless driving.
- Make sure operators are 16 or older with a valid driver's license.
- Do not let people drive or ride after using alcohol or drugs.
- Do not allow operation on public roads (unless designated for off-highway vehicle access) - collisions with cars and trucks can occur.

Do not exceed seating capacity:

**RZR** - 1 passenger

**RZR 4** - 3 passengers

---

## RIDERS WARNING

### Be Sure Riders Pay Attention and Plan Ahead

If you think or feel the vehicle may tip or roll, reduce your risk of injury:

- Keep a firm grip on the steering wheel or hand holds and brace yourself.
- Do not put any part of your body outside of the vehicle for any reason.

## DRIVE RESPONSIBLY WARNING

### WARNING:

#### Drive Responsibly

Rollovers have caused severe injuries and death, even on flat, open areas.

#### Avoid loss of control and rollovers:

- Avoid abrupt maneuvers, sideways sliding, skidding or fishtailing, and never do donuts.
- Slow down before entering a turn.
- Avoid hard acceleration when turning, even from a stop.
- Plan for hills, rough terrain, ruts and other changes in traction and terrain.
- Avoid paved surfaces.
- Avoid sidehilling (riding across slopes).



## FUEL TRANSPORT WARNING

NEVER carry fuel or other flammable liquids on this vehicle.

Failure to follow this instruction could lead to serious burn injuries or death.



# SAFETY

---

## SEAT BELT WARNING

Improper vehicle use can result in SEVERE INJURY or DEATH.

### Be Prepared

- Fasten seat belts.
- Wear an approved helmet and protective gear.
- ALWAYS use cab nets and/or doors.
- Each rider must be able to sit with back against seat, feet flat on the floor, and hands on steering wheel or hand holds. Stay completely inside the vehicle.



LOCATE AND READ OWNER'S MANUAL. FOLLOW ALL INSTRUCTIONS AND WARNINGS. ALWAYS REVIEW SAFETY VIDEO AND TAKE ROHVA TRAINING ([rohva.org](http://rohva.org)).

## BELT DEBRIS WARNING

- Improper service or maintenance of this PVT system can result in vehicle damage, SEVERE INJURY or DEATH.
- Always look for and remove debris inside and around the clutch and vent system when replacing the belt.
- Read owner's manual or see authorized dealer.

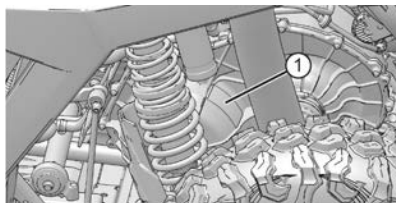

① Belt Debris Warning



## AIR BOX CAUTION

### CAUTION:

Use a Polaris approved air filter. The use of a non-Polaris approved air filter may cause engine damage. Before installing filter, ensure there is no dirt or debris in the clean side of the intake tube. The air filter must be properly seated before the lid is reinstalled. Please reference your owner's manual for additional information regarding air filter service.

#### ① Air Box Caution

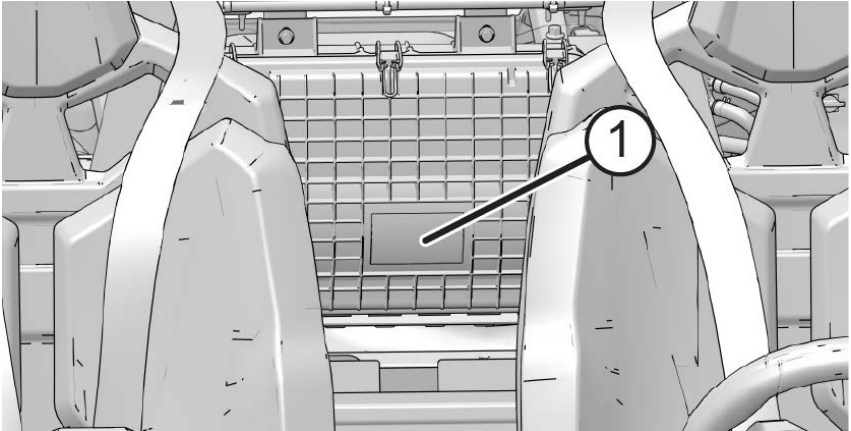

## SAFETY

### LOAD / PASSENGER / TIRE PRESSURE WARNING

The Load / Passenger / Tire Pressure Warning ① is located at the rear of the vehicle in the cargo box.

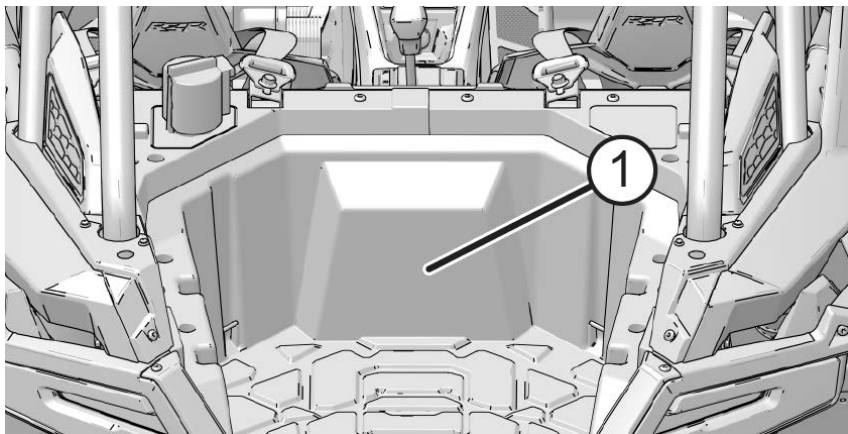

- Never carry passengers in cargo box.
- Passengers can be thrown off. This can cause serious injury or death.

IMPROPER TIRE PRESSURE OR OVERLOADING CAN CAUSE LOSS OF CONTROL RESULTING IN SERIOUS INJURY OR DEATH.

- Reduce speed and allow greater distance for braking when carrying cargo.
- Overloading or carrying tall, off-center, or unsecured loads will increase your risk of losing control. Loads should be centered and carried as low as possible in box.
- For stability on rough or hilly terrain, reduce speed and cargo.

	<b>RZR ProXP</b>	<b>RZR ProXP 4</b>
<b>MAXIMUM CARGO BOX LOAD</b>	300 lbs. (136 kg)	300 lbs. (136 kg)
<b>TIRE PRESSURE IN PSI (KPa)</b>	FRONT 10 (69) REAR 20 (138)	FRONT 16 (110) REAR 20 (138)
<b>MAXIMUM WEIGHT CAPACITY INCLUDES WEIGHT OF OPERATOR, PASSENGERS, CARGO AND ACCESSORIES</b>	740 lbs. (336 kg)	900 lbs. (408 kg)
<b>Read Operation and Maintenance Manual for more detailed loading information.</b>		

## INTERNATIONAL WARNING LABELS

### GENERAL ALERT

Read your owner's manual. Never allow anyone under 16 years of age to operate this vehicle. Never use alcohol or drugs before or while driving or riding. Do not allow operation on public roads (unless designated for off-highway vehicle access). Wear approved helmet, goggles, and protective clothing. Always wear seat belts. Always use the cab nets or doors. Avoid operating in a manner that could result in a rollover. Avoid exhibition driving.

**Label Location:** Behind the gear selector, in between the driver's seat and passenger seat.



### OWNER'S MANUAL ALERT

Read the owner's manual.



## SAFETY

---

### **INTAKE ALERT**

Use a Polaris approved air filter. The use of a non-Polaris approved air filter may cause engine damage. Before installing filter ensure there is no dirt or debris in the clean side of the intake tube. The air filter must be properly seated and the hinges fully inserted when the lid is reinstalled. Please reference your owner's manual for additional information regarding the air filter service.

**Label Location:** On the air box.







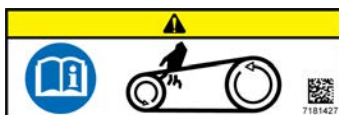









### **CLUTCH COVER ALERT**

Read your owner's manual. Keep body parts away from belt.



**FUEL / LOAD / PASSENGER / TIRE PRESSURE ALERTS**

			PRO XP	PRO XP 4
  	 < 136 kg  7300191		 69 kPa/ 0,69 bar  138 kPa/ 1,38 bar	 110 kPa/ 1,10 bar  138 kPa/ 1,38 bar
	 +  < 336 kg		 +  < 408 kg	
			PRO XP	PRO XP 4
MAXIMUM CARGO BOX LOAD			300 lbs. (136 Kg)	300 lbs. (136 Kg)
TIRE PRESSURE IN PSI (KPa)			FRONT 10 (69) REAR 20 (138)	FRONT 16 (110) REAR 20 (138)
MAXIMUM WEIGHT CAPACITY INCLUDES WEIGHT OF OPERATOR, PASSENGER, CARGO, AND ACCESSORIES.			740 lbs. (336 Kg)	900 lbs. (408 Kg)
Read Operation & Maintenance Manual for more detailed loading information.				

Never carry passengers in cargo box. Passengers can be thrown off. This can cause serious injury or death. Read owner's manual. Never carry or transport fuel on this vehicle.

MODEL	MAXIMUM CARGO BOX LOAD	TIRE PRESSURE (IN KPA / BAR)	MAXIMUM CAPACITY
PRO XP	136 kg	Front: 69 (0,69) Rear: 138 (1,38)	Occupants: 2 (Occupants + Tow Load) Weight: 336 kg
PRO XP 4		Front: 110 (1,10) Rear: 138 (1,38)	Occupants: 4 (Occupants + Tow Load) Weight: 408 kg

### SAFETY WARNINGS

 **WARNING**

Failure to operate this vehicle properly can result in a collision, loss of control, accident or rollover, which may result in serious injury or death. Heed all safety warnings outlined in this section of the owner's manual and in the safety DVD provided with your vehicle. See the OPERATION section of the owner's manual for proper operating procedures.

### OPERATING WITHOUT INSTRUCTION

Operating this vehicle without proper instruction increases the risk of an accident. The operator must understand how to operate the vehicle properly in different situations and on different types of terrain. Take a training course and complete the steps outlined in the New Operator Driving Procedures section.

All operators must read and understand the owner's manual and all warning and instruction labels before operating the vehicle.

Never allow a guest to operate this vehicle until the guest has completed the steps outlined in the New Operator Driving Procedures section.

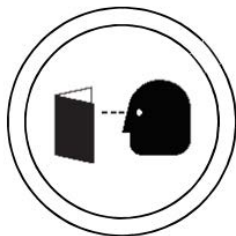

### OPERATOR RESTRICTIONS / AGE RESTRICTIONS

This vehicle is an ADULT VEHICLE ONLY. Operation is prohibited for anyone under 16 years of age or anyone without a valid driver's license.

All operators and (if applicable) riders must be able to sit with backs against the seat, both feet flat on the floor and both hands on the steering wheel (if driving) or on a passenger hand hold.



## USING ALCOHOL OR DRUGS

Operating this vehicle after consuming alcohol or drugs could adversely affect operator judgment, reaction time, balance and perception.

Never consume alcohol or drugs before or while operating this vehicle.



## FAILURE TO INSPECT BEFORE OPERATING

### WARNING

Failure to inspect and verify that the vehicle is in safe operating condition before operating increases the risk of an accident. Always perform the Pre-Ride Inspection outlined in the Operation chapter before each use of your vehicle to make sure it's in safe operating condition. Always follow the inspection and maintenance procedures and schedules described in this owner's manual. See the Periodic Maintenance section of the Maintenance chapter.

## PROTECTIVE APPAREL

Riding in this vehicle without wearing an approved helmet and protective eyewear increases the risk of a serious injuries in the event of an accident. Operator and all passengers must always wear a helmet, eye protection, gloves, long-sleeve shirt, long pants and over-the-ankle boots.



## SEAT BELTS

Riding in this vehicle without wearing the seat belt increases the risk of serious injury in the event of rollover, loss of control, other accident or sudden stop. Seat belts may reduce the severity of injury in these circumstances.

All riders *must* wear seat belts at all times.

## SAFETY

---

### CAB DOORS

Riding in this vehicle without closed and latched cab doors increases the risk of serious injury or death in the event of an accident or rollover. Always make sure all cab doors are closed and latched while riding in this vehicle. Cab doors are NOT intended to be used as arm rests. *Keep hands and feet inside the vehicle at all times.*

### CARRYING MULTIPLE PASSENGERS (RZR 2-SEAT)

Never carry a passenger until you have operated this vehicle for at least two hours and have completed the steps in the New Operator Driving Procedures section. A passenger must always be seated in a passenger seat with seat belt secured. Carrying more than one passenger in a 2-seat vehicle can affect the operator's ability to steer and operate the controls, which increases the risk of loss of control and accident or rollover. Never carry more than one passenger in a 2-seat vehicle.



### CARRYING MULTIPLE PASSENGERS (RZR 4-SEAT)

Never carry a passenger until you have operated this vehicle for at least two hours and have completed the steps in the New Operator Driving Procedures section.

A passenger must always be seated in a passenger seat with seat belt secured.

Never carry more than three passengers in a 4-seat vehicle.

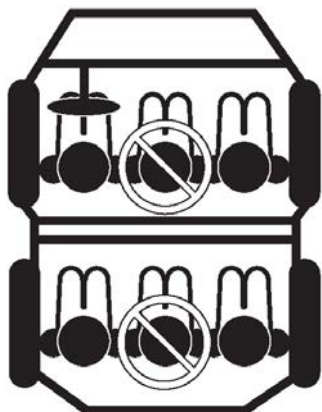



## OPERATING WITH A LOAD ON THE VEHICLE

The weight of both cargo and passengers impacts vehicle operation and stability. For your safety and the safety of others, carefully consider how your vehicle is loaded and how to safely operate the vehicle. Follow the instructions in this manual for loading, tire pressure, gear selection and speed.

- **Do not exceed vehicle weight capacities.** The vehicle's maximum weight capacity is listed in the specifications section of this manual and on a label on the vehicle. When more passenger weight is added, cargo weight may need to be reduced accordingly.
- The recommended tire pressures are listed in the specifications section of this manual and on a label on the vehicle.

**Always follow these guidelines:**

Under ANY of these conditions:	Do ALL of these steps:
Passenger and/or cargo exceeds half the maximum weight capacity	<ol style="list-style-type: none"> <li>1. Slow down.</li> <li>2. Verify tire pressure.</li> <li>3. Use extra caution when operating.</li> </ol>
Operating in rough terrain	
Operating over obstacles	
Climbing an incline	
Towing	

## PASSENGERS IN THE CARGO BOX

Carrying a passenger in the cargo box could result in a fall from the vehicle or contact with moving components. Never allow a passenger to ride in the cargo box. A passenger must always be seated in a passenger seat with seat belt secured.



## OPERATING ON PAVEMENT

This vehicle's tires are designed for off-road use, not for use on pavement. Operating this vehicle on paved surfaces (including sidewalks, paths, parking lots and driveways) may adversely affect the handling of the vehicle and may increase the risk of loss of control and accident or rollover. Avoid operating the vehicle on pavement. If it's unavoidable, travel slowly, travel short distances and avoid sudden turns or stops.

## SAFETY

---

### OPERATING ON PUBLIC ROADS

Operating this vehicle on public streets, roads or highways could result in a collision with another vehicle. Never operate this vehicle on any public street, road or highway, including dirt and gravel roads (unless designated for off-highway use).



### OPERATING AT EXCESSIVE SPEEDS

Operating this vehicle at excessive speeds increases the operator's risk of losing control. Always operate at a speed that's appropriate for the terrain, the visibility and operating conditions, your skills and experience and your passengers' skills and experience.



### TURNING IMPROPERLY

Turning improperly could cause loss of traction, loss of control, accident or rollover. Always follow proper procedures for turning as described in this owner's manual.

Avoid sharp turns. Never turn while applying heavy throttle. Never make abrupt steering maneuvers. Practice turning at slow speeds before attempting to turn at faster speeds.

### JUMPS AND STUNTS

Exhibition driving increases the risk of an accident or rollover. **DO NOT** do power slides, "donuts", jumps or other driving stunts. Avoid exhibition driving.



## IMPROPER HILL CLIMBING

Improper hill climbing could cause loss of control or rollover. Use extreme caution when operating on hills. Always follow proper procedures for hill climbing as described in this owner's manual. See the Driving Uphill section for details.



## DESCENDING HILLS IMPROPERLY

Improperly descending a hill could cause loss of control or rollover. Always follow proper procedures for traveling down hills as described in this owner's manual. See the Driving Downhill section for details.

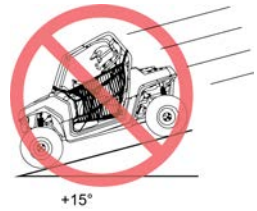

## CROSSING HILLSIDES

Driving on a sidehill is not recommended. Improper procedure could cause loss of control or rollover. Avoid crossing the side of any hill unless absolutely necessary.

If crossing a hillside is unavoidable, always follow proper procedures as described in this owner's manual. See the Driving on a Sidehill (Sidehilling) section for details.

## STALLING WHILE CLIMBING A HILL

Stalling or rolling backwards while climbing a hill could cause a rollover. Maintain a steady speed when climbing a hill.

*If you lose all forward speed:*

Apply the brakes gradually until the vehicle is fully stopped. Place the transmission in reverse and slowly allow the vehicle to roll straight downhill while applying light brake pressure to control speed.



## SAFETY

---

### OPERATING IN UNFAMILIAR TERRAIN

Failure to use extra caution when operating on unfamiliar terrain could result in an accident or rollover.

Unfamiliar terrain may contain hidden rocks, bumps, or holes that could cause loss of control or rollover.

Travel slowly and use extra caution when operating on unfamiliar terrain. Always be alert to changing terrain conditions.



### OPERATING IMPROPERLY IN REVERSE

Improperly operating in reverse could result in a collision with an obstacle or person. Always follow proper operating procedures as outlined in this manual. See the Driving in Reverse section for details.

Before shifting into reverse gear, always check for obstacles or people behind the vehicle. When it's safe to proceed, back slowly.



### IMPROPER TIRE MAINTENANCE

Operating this vehicle with improper tires or with improper or uneven tire pressure could cause loss of control, accident or rollover.

Always use the size and type of tires specified for your vehicle. Always maintain proper tire pressure as described in this owner's manual and on safety labels.

### SKIDDING OR SLIDING

Failure to use extra caution when operating on excessively rough, slippery or loose terrain could cause loss of traction, loss of control, accident or rollover. Do not operate on excessively slippery surfaces. Always slow down and use additional caution when operating on slippery surfaces.

Skidding or sliding due to loss of traction can cause loss of control or rollover (if tires regain traction unexpectedly). Always follow proper procedures for operating on slippery surfaces as described in this owner's manual. See the Driving on Slippery Surfaces section for details.

## OPERATING OVER OBSTACLES

Improperly operating over obstacles could cause loss of control or rollover.

Before operating in a new area, check for obstacles. Never attempt to operate over large obstacles such as large rocks or fallen trees. Always follow the proper procedures outlined in this manual when operating over obstacles. See the Driving Over Obstacles section for details.



## OPERATING THROUGH WATER

Operating through deep or fast-flowing water can cause loss of traction, loss of control, rollover or accident. Never operate in fast-flowing water or in water that exceeds the floor level of the vehicle.

Always follow proper procedures for operating in water as described in this owner's manual. See the Driving Through Water section for details.

Wet brakes may have reduced stopping ability. After leaving water, test the brakes. Apply them lightly several times while driving slowly. The friction will help dry out the pads.



## OPERATING IN COLD WEATHER



Always be adequately prepared when operating in cold weather, especially below-freezing temperatures. Cold weather can affect the engine's ability to start, which can be dangerous when operating in unfamiliar or remote areas.

## OPERATING ON FROZEN BODIES OF WATER

Severe injury or death can result if the vehicle and/or the operator fall through the ice. Never operate the vehicle on a frozen body of water unless you have first verified that the ice is sufficiently thick to support the weight and moving force of the vehicle, you and your passengers, and your cargo, together with any other vehicles in your party.

Always check with local authorities and residents to confirm ice conditions and thickness over your entire route. Vehicle operators assume all risk associated with ice conditions on frozen bodies of water.



## SAFETY

---

### OPERATING A DAMAGED VEHICLE

Operating a damaged vehicle can result in an accident. After any rollover or other accident, have a qualified service dealer inspect the entire machine for possible damage, including (but not limited to) seat belts, rollover protection devices, brakes, throttle and steering systems.

### IMPROPER CARGO LOADING

Overloading the vehicle or carrying cargo improperly may cause changes in stability and handling, which could cause loss of control or an accident.

- Always follow the instructions in this owner's manual for carrying cargo. See the Hauling Cargo section for details.
- Never exceed the stated load capacity for this vehicle.
- Cargo should be properly distributed and securely attached. See the Hauling Cargo section for details.
- Reduce speed when carrying cargo. Allow a greater distance for braking.



### EXPOSURE TO EXHAUST

Engine exhaust fumes are poisonous and can cause loss of consciousness or death in a short time. Never start the engine or let it run in an enclosed area.

Operate this vehicle only outdoors or in well-ventilated areas.

### HOT EXHAUST SYSTEMS

#### WARNING

Exhaust system components are very hot during and after use of the vehicle. Hot components can cause burns and fire. Do not touch hot exhaust system components. Always keep combustible materials away from the exhaust system.

Use caution when traveling through tall grass, especially dry grass, and when traveling in muddy conditions. Always inspect the underside of the vehicle and areas near the exhaust system after driving through tall grass, weeds, brush, other tall ground cover, and muddy conditions. Promptly remove any grass, debris, or foreign matter clinging to the vehicle. Pay particular attention to the exhaust system area.

## REFUELING

Gasoline is highly flammable and explosive under certain conditions.

- Always exercise extreme caution whenever handling gasoline.
- Always turn off the engine when refueling.
- Always refuel outdoors or in a well ventilated area free of any source of flame or sparks.
- NEVER carry fuel or other flammable liquids on this vehicle. Failure to follow this instruction could lead to serious burn injuries or death.
- Do not smoke or allow open flames or sparks in or near the area where refueling is performed or where gasoline is stored.
- Do not overfill the tank. Do not fill the tank neck.
- If gasoline spills on your skin or clothing, immediately wash it off with soap and water and change clothing.

## UNAUTHORIZED USE OF THE VEHICLE

Leaving the keys in the ignition can lead to unauthorized use of the vehicle by someone under the age of 16, without a drivers license, or without proper training. This could result in an accident or rollover. Always remove the ignition key when the vehicle is not in use.

## EQUIPMENT MODIFICATIONS

Your POLARIS vehicle is designed to provide safe operation when used as directed. Modifications to your vehicle may negatively impact vehicle stability. Failure of critical machine components may result from operation with any modifications, especially those that increase speed or power. This vehicle may become less stable at speeds higher than those for which it is designed. Loss of control may occur at higher speeds.

Do not install any non-POLARIS-approved accessory or modify the vehicle for the purpose of increasing speed or power. Any modifications or installation of non-POLARIS-approved accessories could create a substantial safety hazard and increase the risk of bodily injury.

The POLARIS limited warranty on your POLARIS vehicle will be terminated if any non-POLARIS-approved equipment and/or modifications have been added to the vehicle that increase speed or power.

The addition of certain accessories, including (but not limited to) mowers, blades, tires, sprayers, or large racks, may change the handling characteristics of the vehicle. Use only POLARIS-approved accessories, and familiarize yourself with their function and effect on the vehicle.

**FOR MORE INFORMATION ABOUT SAFETY  
call POLARIS at 1-800-342-3764.**





## FEATURES AND CONTROLS COMPONENT LOCATIONS

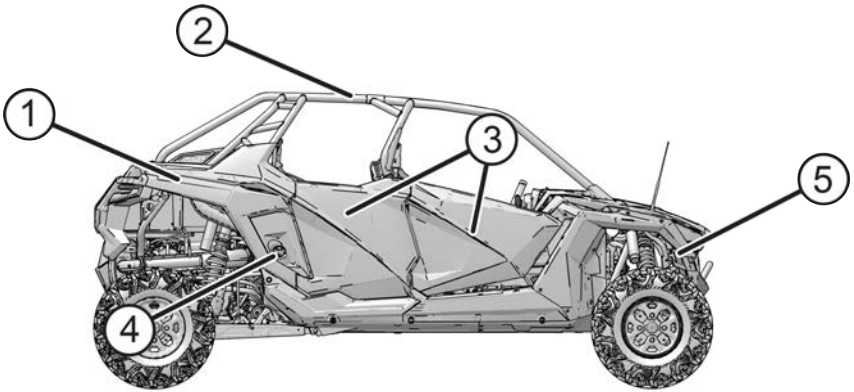
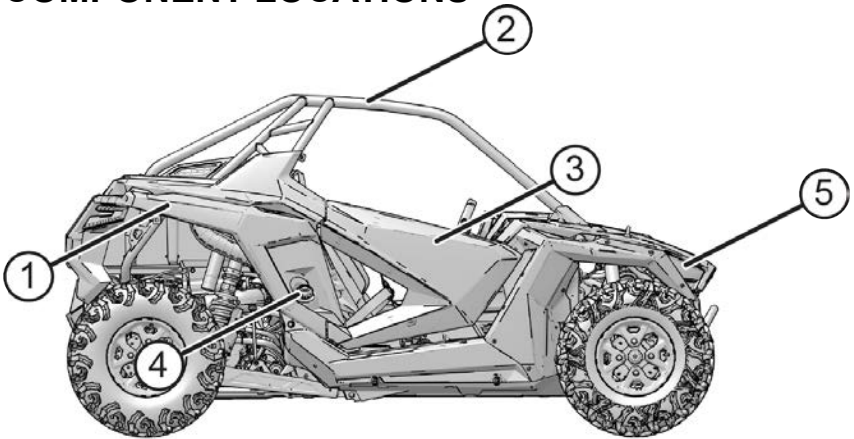

- ① Cargo Box
- ② ROPS Frame
- ③ Cab Door
- ④ Fuel Tank Cap
- ⑤ Radiators

### STANDARD STEERING WHEEL (IF EQUIPPED)

The steering wheel can be tilted upward or downward for rider preference. Lift and hold the steering wheel adjustment lever ① while moving the steering wheel upward or downward. Release the lever when the steering wheel is at the desired position.

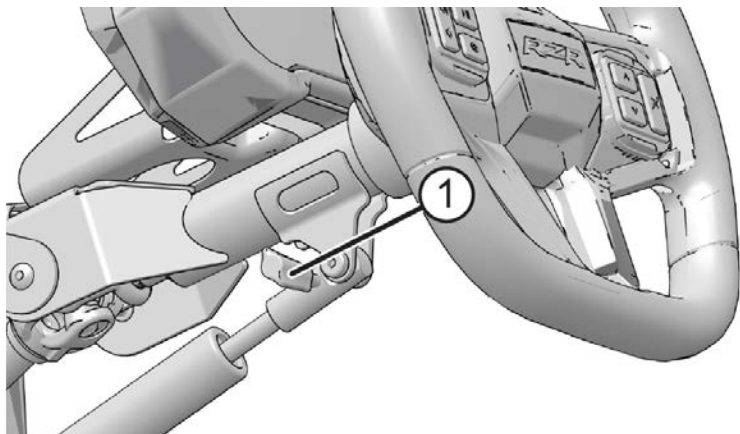

### TELESCOPE STEERING WHEEL (IF EQUIPPED)

The telescoping steering wheel can be adjusted by pressing the release lever ① downward. Once released, the steering wheel can be tilted up/down and telescoped in/out freely. When desired position is found, hold the steering wheel in place with one hand and pull the release lever back up with the other. The release lever will catch into place when it is locked.

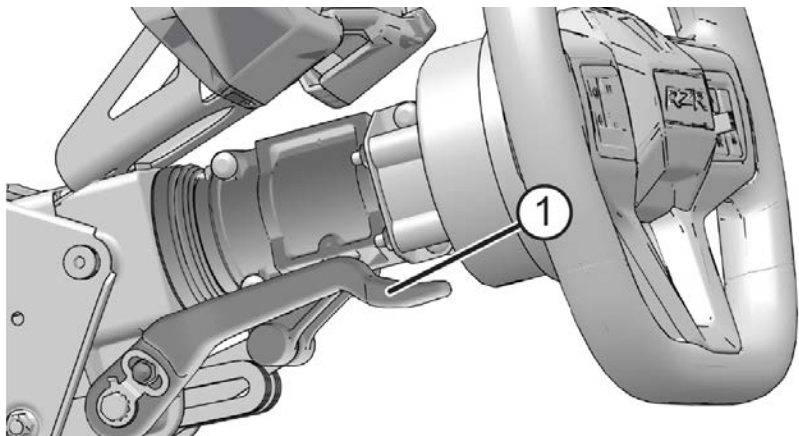

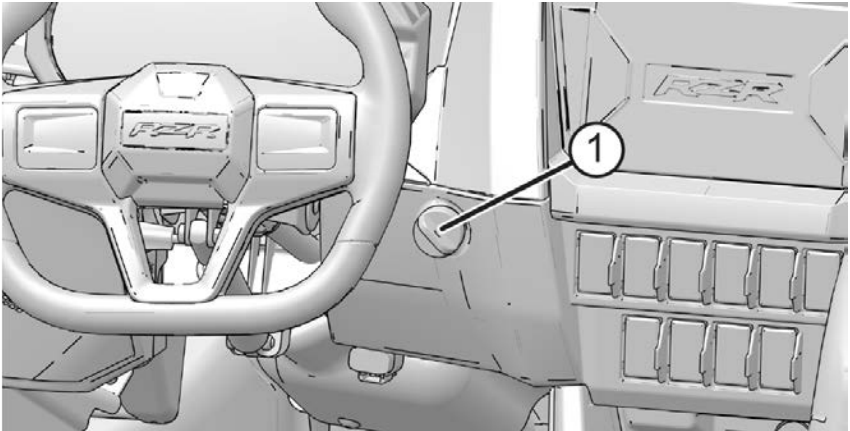
**SWITCHES****IGNITION SWITCH**

The ignition switch ① is a four-position, key-operated switch. Use the ignition switch to start the engine. See the Starting the Engine section for starting procedures.

POSITION	FUNCTION
OFF	The engine is off. Electrical circuits are off, except accessory 12V.
ACCESSORY	The engine is off. Powers the display, terminal block, and front/rear accent lights. Check engine and power steering warning indicators will appear on the display in this mode but will turn off when the vehicle is started if no issues are present.
ON	Electrical circuits are on. Electrical equipment can be used.
START	The vehicle must be in PARK or NEUTRAL before the engine can start. To start the vehicle, press the brake pedal, turn the key to the start position, and then release. The engine will turn over for about 5 seconds or until started.

The key can be removed from the switch when it is in the OFF position.

## FEATURES AND CONTROLS

---

### HEADLIGHT SWITCH

The ignition switch key must be in the ON/RUN position to operate the headlights. The headlight switch is a toggle and has three positions:

UP – High Beam

CENTER – Low Beam

DOWN – Headlights Off



### ALL WHEEL DRIVE (AWD) SWITCH

The ignition switch key must be in the ON/RUN position to operate the headlights. The All Wheel Drive switch is a toggle and has two positions:

UP – All Wheel Drive (AWD)

CENTER – Two Wheel Drive (2WD)



### AUXILIARY OUTLETS

The vehicle is equipped with two 12-volt accessory outlets.

**For two-seat vehicles,** one is in the front portion of the center console, in front of the gear selector. The other is in the armrest storage bin.

**For four-seat vehicles,** one is in the front portion of the center console, in front of the gear selector. The other is in the rear center console bin.

Use the outlets to power an auxiliary light or other optional accessories.



### **ELECTRONIC POWER STEERING (EPS)**

Electronic power steering (if equipped) engages when the ignition key is turned to the ON position. EPS remains engaged whether the vehicle is moving or idle.

The EPS warning indicator briefly illuminates when the key is turned to the ON position. See the Indicator Lamps section for details.

To conserve battery power, the EPS will shut down 5 minutes after the engine is stopped if the key remains in the ON position. The EPS warning indicator will illuminate to indicate the EPS has shut down.

If the light remains on after starting the engine, the EPS system is inoperative. See your POLARIS dealer, or another qualified person, as soon as possible for repair. Continued operation could result in permanent damage to the EPS unit and increased steering effort.

### **STEERING WHEEL CONTROLS**

#### **SUSPENSION CONTROLS (IF EQUIPPED)**

If equipped, suspension controls can be found on the right-hand side of the steering wheel. There are 3 available suspension modes to select from: Firm, Sport, and Comfort.

The firmness of the suspension can be adjusted by pressing the UP button (more firm) or the DOWN button (less firm).

The momentary MAX FIRM button is on the right. When this button is pressed, the suspension will immediately switch to maximum firmness. The vehicle will maintain this setting if the button is continuously pressed. Once the button is released, maximum firmness will persist temporarily, and then revert back to the previous setting.

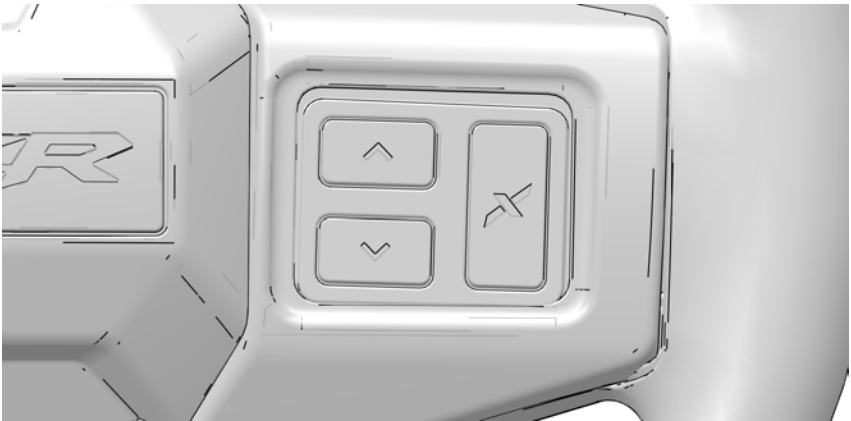

## FEATURES AND CONTROLS

---

### WARNING

The operator should use caution to select the appropriate suspension mode to match the current terrain conditions and driving style. Failure to select an appropriate suspension mode could lead to vehicle dynamic behaviors not matched to the terrain or driver's skill level.

### NOTICE

The system will prevent mode transitions from a more firm operating mode to a more soft operating mode when a current active vehicle state is present (cornering, braking, accelerating, or airborne).

In **Firm Mode**, the compression damping reverts to a firm setting with suspension response optimized for harsh terrain. Recommended for terrain where suspension would be put under more stress.

In **Sport Mode**, some rider comfort is traded for responsiveness. Damping ramps up more aggressively as a function of vehicle speed. Recommended for spirited driving where additional suspension system performance with regard to cornering, braking, acceleration, sidehilling, and airborne detection may be required.

In **Comfort mode**, the suspension control system is optimized for rider comfort, intervening in performance situations only where required. Recommended for less challenging terrain and more moderate operation.

### AUDIO CONTROLS (IF EQUIPPED)

If equipped, audio controls can be found on the left-hand side of the steering wheel.

Volume can be adjusted by pressing the bottom (lower volume) or the top (higher volume) of the button.

Audio can be paused or resumed by pressing the pause button.

Refer to the Ride Command manual for operating the third Polaris button.

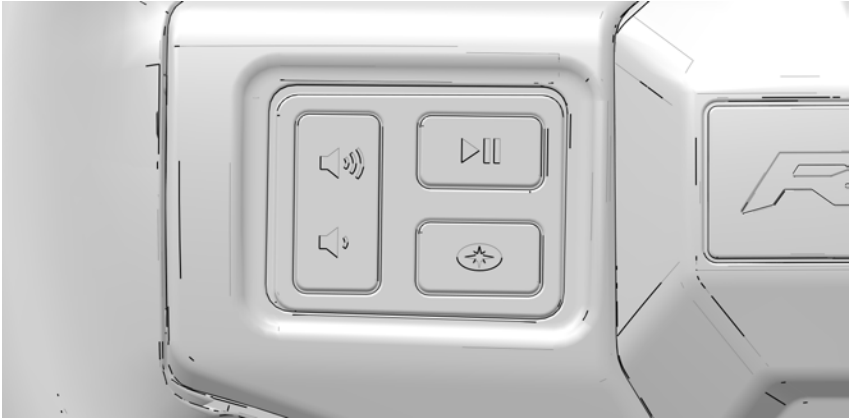

### SEATS



Prolonged sun exposure can cause excessive heating of the steering wheel and seats. Use caution when handling hot surfaces to avoid burns.

Before operating the vehicle, always push down on all seat backs to ensure the latches are secure.

### FRONT SEAT REMOVAL

1. Pull up on the seat latch lever① located under the front edge of the seat.

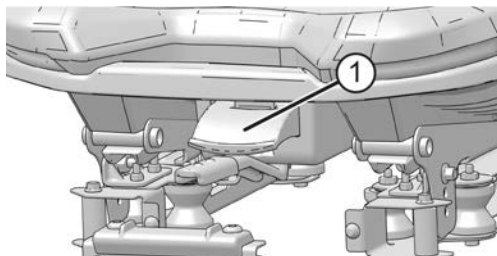

2. Tilt the seat forward.
3. Lift the seat upward to remove it from the vehicle.
4. Reverse this procedure to reinstall the seat. Make sure the seat tabs at the front edge of the seat slide onto the seat retainer tubes.
5. Press down firmly at the rear of the seat to engage the rear latch.



### REAR SEAT REMOVAL

Both rear seats can be modified to allow for additional storage space. Use the following procedure.

1. Reach behind the headrest and pull on the latch① to release the seat back.

**OPTIONAL:** The seat back can be removed entirely or reinstalled once seat base is flipped, depending on preference.

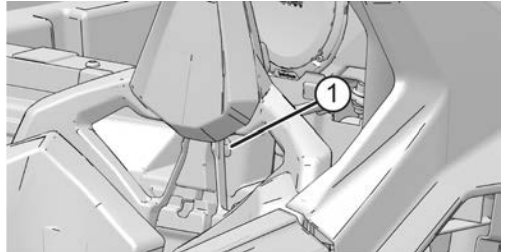

2. Once the seat back is removed, grab one of the straps② at the rear of the seat base.

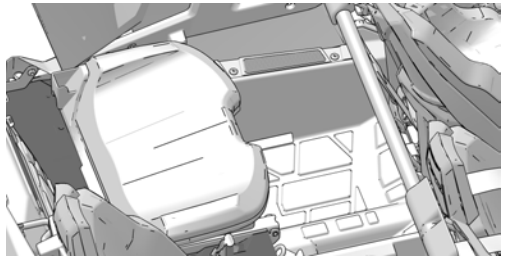

3. Use the straps to pull upward and flip the seat base completely over.

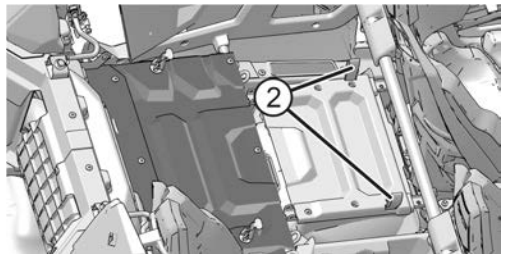

4. To reinstall the seat back, align the bottom stems with their appropriate housings. Once aligned, push the seat headrest back until the latch makes an audible 'click' sound.

## FEATURES AND CONTROLS

If needed, there are 8 tie-down points③ (4 for each seat area) available for holding down stored items.

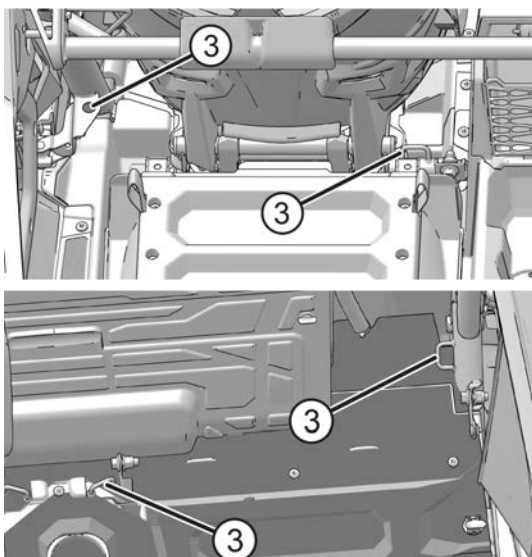

## SEAT ADJUSTMENTS

### CAUTION

Be mindful of hands and fingers when adjusting the seat. Placing hands or fingers in the path of the exposed rollers can lead to injury.

The front seats are equipped with an adjustment lever① under the front edge of the seat, pull the lever to the left. Slide the seat forward or rearward to the desired position. Release the lever. The seat will lock into the new position.

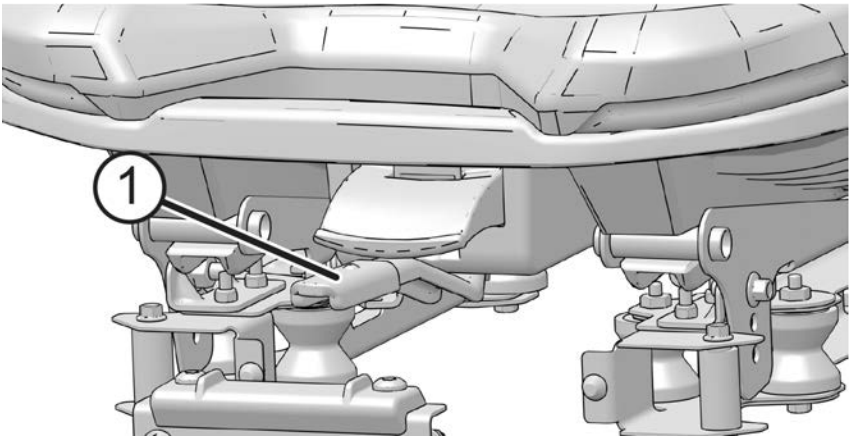

To adjust seat tilt, adjustment bolts can be removed and re-installed at a different tilt setting. The driver side has two adjustment bolts<sup>②</sup>, one on each side, and has three tilt hole options.

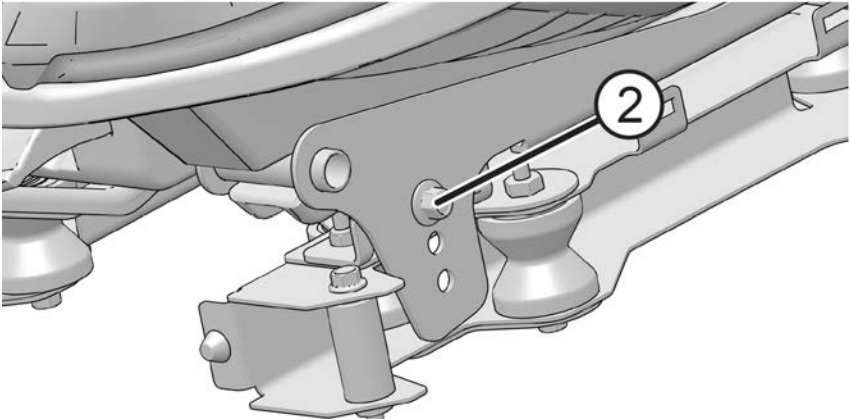

The rear passenger seats cannot be adjusted for comfort. They can only be adjusted/removed to make room for storage. See the Seat Removal section for details.

## FEATURES AND CONTROLS

---

### PASSENGER HAND HOLD

Always adjust the hand hold to a comfortable position for your passenger before operating. Make sure the clasps① are fully locked after making adjustments.

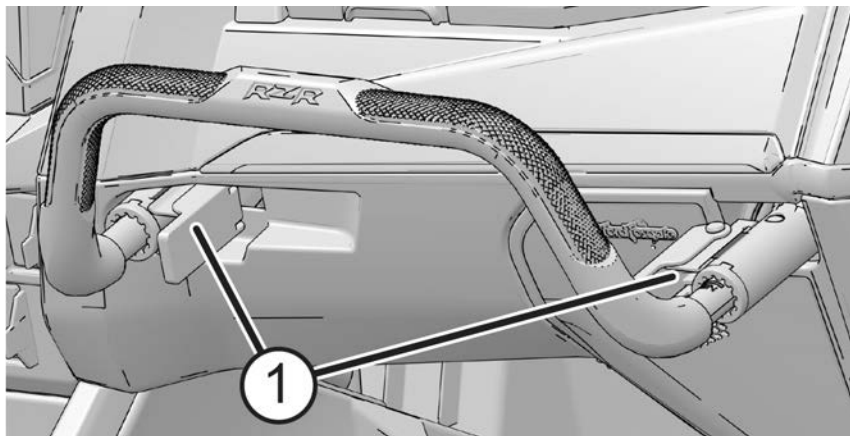

1. To adjust the passenger hand hold, unlock both clasps① on each side.
2. Pull/Push the bar to desired position.
3. Lock both clasps back into place.

### FUEL RECOMMENDATIONS

- Use ONLY 91 octane (or higher) unleaded fuel (minimum pump octane number of 91 R+M/2)
- Do not use any fuel lower than 91 octane
- Do not use fuel containing more than 10% ethanol (including E85)

### FUEL LEVEL

The fuel tank filler cap ① is located on the right side of the vehicle near the passenger seat.

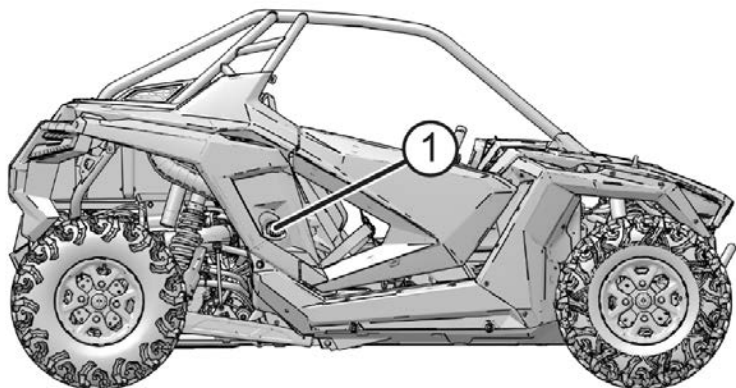

The fuel symbol and the last fuel bar on the MFD gauge will blink when the fuel level reaches 1/8th tank. There will be approximately 4 gallons (14 L) of fuel remaining. Refuel as soon as possible. *Do not allow the vehicle to run out of fuel.* Secure the fuel cap by tightening until an audible 'click' is heard twice.

#### NOTICE

Damage to the fuel pump will occur if the vehicle is operated with an empty fuel tank. Do not allow the vehicle to run out of fuel. Always refuel when the level is low.

#### NOTICE

Operating with obstructed fuel systems will result in serious engine damage. Perform maintenance as recommended.

#### NOTICE

Prolonged exposure to petroleum based products may damage paint. Always protect painted surfaces when handling fuel.

### SEAT BELTS

This POLARIS vehicle is equipped with seat belts for all riders. Always make sure the seat belts are secured for the operator and all passengers before riding. The driver's seat belt is equipped with a seat belt interlock. Vehicle speed will be limited to 15 MPH (24 km/h) if the seat belt is not secured.

## FEATURES AND CONTROLS

---

### 3-POINT SEAT BELT

To wear the 3-point seat belt properly, follow this procedure:

1. Pull the seat belt latch downward and across your chest toward the buckle at the inner edge of the seat. The belt should fit snugly across your hips and diagonally across your chest. Make sure the belt is not twisted.
2. Push the latch plate into the buckle until it clicks. Pull up on the strap to tighten.
3. Press the red release latch on the buckle to release the seat belt.

### 6-POINT SEAT BELT



Be sure to follow the procedures below exactly as described. Improperly securing the seat belt can result in free movement during operation, which can lead to injury.

This vehicle is equipped with a Click-6 safety harness with built-in interlock. To wear the 6-point seat belt properly, follow this procedure:

1. Pull both the seat belt latch and buckle across your chest.
2. Push the latch plate into the buckle until it clicks.
3. Pull on the adjustment straps to tighten the straps on your hips and thighs.
4. **On four-seat vehicles**, the rear seats are not equipped with automatic retractors. The shoulder straps must be manually tightened to become fully secured.
5. To release the seat belt, press the red release latch on the buckle.

### SEAT BELT INSPECTION

Inspect all seat belts for proper operation before each use of the vehicle.

1. Pull each seat belt completely out and inspect the full length for any damage, including cuts, wear, fraying or stiffness. If any damage is found, or if the seat belt does not operate properly, have the seat belt system checked and/or replaced by a qualified technician.
2. To clean dirt or debris from the seat belts, sponge the straps with mild soap and water. Do not use bleach, dye or household detergents. Rinse the entire length of the belt webbing.

## SERVICE ACCESS PANELS

### ENGINE ACCESS PANEL

The engine access panel is located behind the seats. Adjust or remove the seats, then remove the panel to reach serviceable engine components. Remove the panel by turning the close-off knobs ① 1/4 turn.

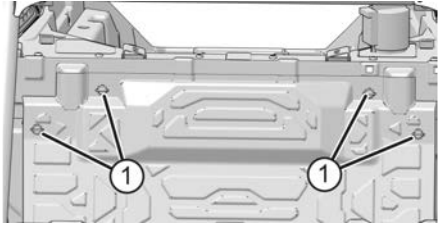

### CARGO BOX ACCESS

**⚠ CAUTION**

The cargo box rests directly above heat-generating vehicle components. Be careful when removing the cargo box immediately following operation. It will likely be hot and could cause burns.

The entire cargo box layer can be lifted to access the engine oil fill cap and spark plugs by removing the four rear-most screws ②.

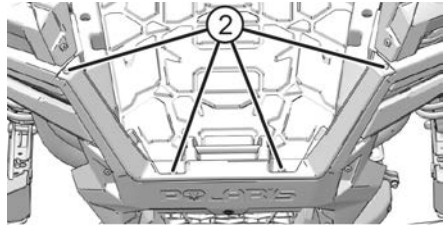

## FEATURES AND CONTROLS

---

### REAR CARGO BOX

There are eight tie-down locations① in the rear cargo box.

**On four-seat vehicles**, the rear seat backs can be removed and seat bases can be flipped forward to allow more room for storage. See the Rear Seat Removal section for details.

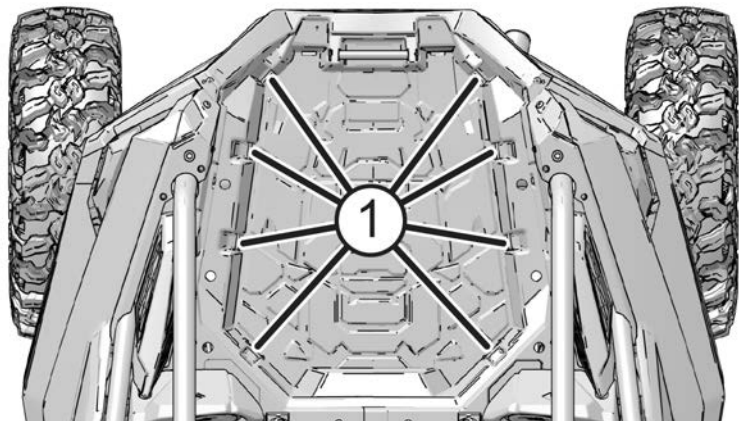

### CAB DOORS

This vehicle is equipped with cab doors. Riding in this vehicle without closed and latched cab doors increases the risk of serious injury or death in the event of an accident or rollover. Always make sure all cab doors are closed and latched when riding in this vehicle.

Always inspect doors and latches for wear and damage before each use of the vehicle.

Promptly replace any worn or damaged parts with new parts available from your authorized POLARIS dealer or qualified person.



### ROLLOVER PROTECTIVE STRUCTURE (ROPS)

The Rollover Protective Structure (ROPS) on this vehicle meets OSHA 1928.53 rollover performance requirements. Always have your authorized POLARIS dealer thoroughly inspect the ROPS if it ever becomes damaged in any way.

#### NOTE

Be mindful of the ROPS bars when boarding and exiting the vehicle.

#### ① ROPS Label

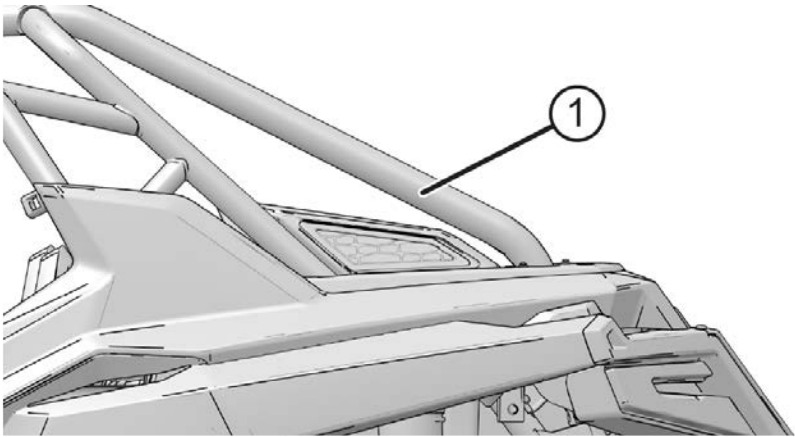

*No device can assure occupant protection in the event of a rollover. When used with seat belts and cab nets or doors, the ROPS helps prevent occupants from being ejected from the vehicle. Always follow all safe operating practices outlined in this manual to avoid vehicle rollover.*

#### WARNING

Vehicle rollover could cause severe injury or death. Always avoid operating in a manner that could result in vehicle rollover.

### GEAR SELECTOR

- P: Park
- R: Reverse
- N: Neutral
- L: Low Gear
- H: High Gear

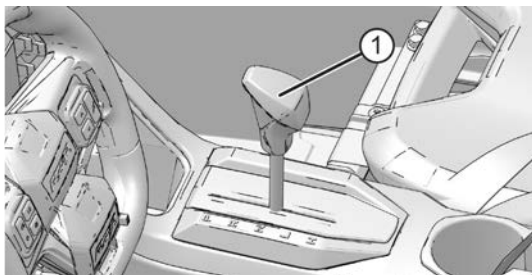

To change gears, stop the vehicle, and with the engine idling, move the lever ① to the desired gear. Do not attempt to shift gears with engine speed above idle or while the vehicle is moving.

#### TIP

Maintaining shift linkage adjustment is important to assure proper transmission function. Your POLARIS dealer can assist in resolving any shifting problems.

#### NOTICE

Do not attempt to shift the transmission while the vehicle is moving or damage to the transmission could result. Always shift when the vehicle is stationary and the engine is at idle.

### USING LOW RANGE

Always shift into low gear for any of the following conditions:

- Operating in rough terrain or over obstacles
- Loading the vehicle onto a trailer

### BRAKE AND THROTTLE PEDALS

#### BRAKE PEDAL

Depress the brake pedal ① to slow or stop the vehicle. The brakes must be applied in order to start the engine.

#### THROTTLE PEDAL

Push the throttle pedal ② down to increase engine speed. Spring pressure returns the pedal to the rest position when released. Always check that the throttle pedal returns normally before starting the engine.

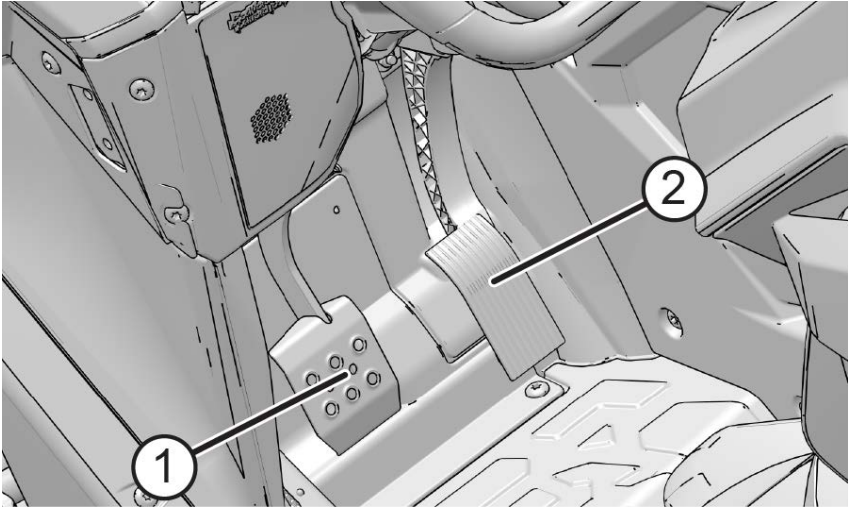

#### TIP

If the throttle pedal and brake pedal are applied simultaneously, engine power may be limited.

## FEATURES AND CONTROLS

### ALL WHEEL DRIVE (AWD) SYSTEM

The All Wheel Drive system is controlled by the AWD switch. Once the vehicle is in gear, the switch is set to one of two modes. When the switch is on 2X4 ②, the vehicle is in two-wheel drive at all times. When the switch is on AWD ①, the vehicle is in all wheel drive and the 4X4 indicator in the instrument cluster will be on.

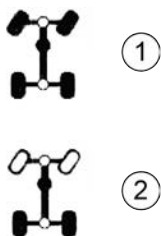

When in AWD, the demand drive unit will automatically engage any time the rear wheels lose traction. When the rear wheels regain traction, the demand drive unit will automatically disengage.

There is no limit to the length of time the vehicle may remain in AWD.

### ENGAGING AWD

The AWD switch may be turned on or off while the vehicle is moving. Initially, the vehicle's electronic system will not enable the AWD until the engine RPM is below 3100. Once enabled, the AWD remains enabled until the AWD switch is turned off. If the switch is turned off while the demand drive unit is moving, it will not disengage until the rear wheels regain traction.

Engage the AWD switch before getting into conditions where all-wheel drive may be needed. If the rear wheels are spinning, release the throttle before switching to AWD.

#### NOTICE

Switching to AWD while the rear wheels are spinning or slipping may cause severe drive shaft and gearcase damage. Always switch to AWD while the rear wheels have traction or are at rest.

## INSTRUMENT CLUSTER

### NOTICE

High water pressure may damage components. Wash the vehicle by hand or with a garden hose using mild soap. Certain products, including insect repellents and chemicals, will damage the speedometer lens and other plastic surfaces. Do not use alcohol to clean the instrument cluster. Do not allow insect sprays to contact the lens. Immediately clean off any gasoline that splashes on the instrument cluster.



- ① Speedometer
- ② Tachometer
- ③ Indicator Lamps

- ④ Mode Button
- ⑤ Toggle Buttons
- ⑥ Rider Information Center

## FEATURES AND CONTROLS

### SPEEDOMETER

The speedometer displays vehicle speed in either miles per hour (MPH) or kilometers per hour (km/h).

### TACHOMETER

The tachometer displays engine speed in revolutions per minute (RPM).

### MODE AND TOGGLE BUTTONS



Press and hold the MODE button ④ to enter or exit the settings menu. Press and release the MODE button to cycle through Area 1 modes and to select an item.

Press and release either toggle button ⑤ to cycle through the options menu or Area 2 modes. Press and hold either toggle button to reset an item. See page 56.





#### TIP

With the ignition key off, pressing the MODE button or either toggle button will power up the Rider Information Center for 10 seconds to allow viewing of the odometer and the clock.

### INDICATOR LAMPS

LAMP	INDICATES	CONDITION
	Check Engine	This indicator appears if an EFI related fault occurs. Do not operate the vehicle if this warning appears. Serious engine damage could result. Your authorized dealer can assist.
	EPS Warning (if equipped)	This indicator illuminates briefly when the key is turned to the ON position. If the light remains on, the EPS system is inoperative. See your POLARIS dealer, or another qualified person, as soon as possible for repair. Continued operation could result in permanent damage to the EPS unit and increased steering effort.
	Engine Hot	This lamp illuminates to indicate an overheated engine. If the indicator flashes, a severe overheating condition exists.

## FEATURES AND CONTROLS

LAMP	INDICATES	CONDITION
	<p>Neutral</p>	<p>This lamp when the transmission is in neutral and the ignition key is on the ON position.</p>
	<p>Helmet / Seat Belt</p>	<p>This lamp flashes for several seconds when the key is turned to the ON position. The lamp is a reminder to wear helmet and seat belt before operating.</p>
	<p>High Beam</p>	<p>This lamp illuminates when the headlamp switch is set to high beam.</p>
	<p>Chassis Fault</p>	<p>This lamp illuminates when there is an issue with the DYNAMIX suspension system.</p>
	<p>Performance Limited</p>	<p>Not applicable.</p>

## FEATURES AND CONTROLS

### RIDER INFORMATION CENTER

The rider information center is located in the instrument cluster. All segments will light up for one second at start-up.

If the instrument cluster fails to illuminate, a battery over-voltage may have occurred and the instrument cluster may have shut off to protect the electronic speedometer. If this occurs, your POLARIS dealer can provide proper diagnosis.

The information center is set to display standard units of measurement and a 12-hour clock at the factory. To change to metric and/or a 24-hour clock, see the Clock section.

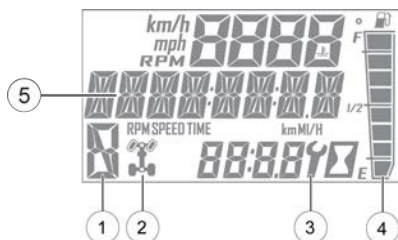

①	Gear Indicator	This indicator displays gear shifter position .H = High Gear L = Low Gear N = Neutral R = Reverse Gear P = Park - = Gear Signal Error (or shifter between gears)
②	AWD Indicator	This indicator shows whether 2X4 or AWD is active when the vehicle is in gear.
③	Service Indicator	A flashing wrench symbol alerts the operator that the preset service interval has been reached. Your POLARIS dealer can provide scheduled maintenance. See page 59 for resetting instructions.
④	Fuel Gauge	The segments of the fuel gauge show the level of fuel in the fuel tank. When the last segment clears, a low fuel warning is activated. The outline of the fuel display will flash. Refuel immediately.
⑤	Speed Limitation (if equipped)	This vehicle may be equipped with a maximum speed limitation function. This would be displayed on the screen as "LIM" followed by the speed. "LIM 30" for example.



## MODE INFORMATION DISPLAYS

The rider information center contains three areas that display mode information.

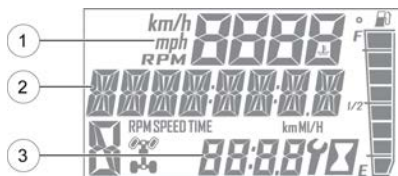

① Area 1 Modes	Description
Engine Temperature	Temperature of engine coolant
Vehicle Speed	Speed of vehicle
Tachometer	Engine speed (RPM)
② Area 2 Modes	Description
Odometer	The odometer records and displays the distance traveled by the vehicle.
Trip Meters (T1/T2)	A trip meter records the distance traveled by the vehicle if reset before each trip. To reset, see page 58.
Engine Hours	Total hours of engine operation since manufacture
Service Hours	A flashing wrench symbol indicates that the preset service interval has been reached. To reset, see page 59.
Trip Time	Time length of vehicle operation since mode was last reset
③ Area 3 Modes	Description
Clock	The clock displays time in a 12-hour or 24-hour format. To reset, see page 57.

## FEATURES AND CONTROLS

---

### ACCESSING MENUS AND OPTIONS

#### GAUGE SETTINGS MENU

Press and release the MODE button to cycle through the Area 1 modes until the desired default mode displays. See the Mode Information Displays section for details.

Press and hold the MODE button to enter the settings menu.

*The OPTIONS screen will display for a few seconds.*

1. Press and release either toggle button to cycle to the desired option.
2. Press MODE to select the option.
3. Press either toggle button to cycle to the desired setting.
4. Press MODE to save and exit to the settings menu.
5. Press and hold the MODE button to exit the settings menu.



#### BACKLIGHT COLOR

The information center backlight can be set to either blue or red.

1. Press and hold the MODE button to enter the settings menu.
2. Press either toggle button to cycle to the "BL COLOR" option. Press MODE to select.
3. Press either toggle button to cycle to the desired setting.
4. Press MODE to save and exit to the settings menu,



### **BACKLIGHT BRIGHTNESS**

The information center backlight can be set to either blue or red.

1. Press and hold the MODE button to enter the settings menu.
2. Press either toggle button to cycle to the "BL LEVEL" option. Press MODE to select.
3. Press "UP" button to increase brightness. Press "DOWN" button to decrease brightness.
4. Press MODE to select and exit to the settings menu.



### **CLOCK**

The clock must be reset any time the battery has been disconnected or discharged.

1. Press and hold the MODE button to enter the settings menu.
2. Press either toggle button to cycle to the "CLOCK" option. Press MODE to select.
3. Press either toggle button to cycle to the desired setting (12H or 24H). Press MODE to select.
4. Press either toggle button to change each segment of the clock. Press MODE to accept a change and advance to the next segment.



## FEATURES AND CONTROLS

### DISPLAY UNITS (STANDARD/METRIC)



1. Press and hold the MODE button to enter the settings menu.
2. Press either toggle button to cycle to the desired “UNITS” option (distance, temperature or volume). Press MODE to select.
3. Press either toggle button to cycle to the desired setting.
4. Press MODE to save and exit to the settings menu.

### TRIP METER

Use a trip meter to track the distance traveled during a specific trip or period of time. Reset the meter to zero before traveling.

1. Press either toggle button to cycle to the desired trip meter option (T1 or T2).
2. Press and hold either toggle button until the meter resets to zero.



### TRIP TIME

Use a trip time meter to track the travel time during a specific trip. Reset the meter to zero before traveling.

1. Press either toggle button to cycle to the trip time option (TT).
2. Press and hold either toggle button until the meter resets to zero.



### **PROGRAMMABLE SERVICE INTERVAL**

The service interval counter is programmed to 25 hours at the factory. As hours of engine operation increase, the counter decreases. The wrench icon will flash for about 10 seconds when the counter reaches zero (0), and each time the key is turned on thereafter, until the counter is reset.

When this feature is enabled, it provides a convenient reminder to perform routine maintenance. Refer to the Periodic Maintenance Chart for recommended service intervals.

Use the following procedure to reset or change the service interval.

1. Press and hold the MODE button to enter the settings menu.
2. Press either toggle button to cycle to the "Service Hours" option. Press MODE to select.
3. Press MODE to reset the existing value and exit, or press either toggle button to change the value. Press MODE to save and exit to the settings menu.



## FEATURES AND CONTROLS

### ENGINE ERROR CODES

The error screen displays only when the CHECK ENGINE indicator is on or when it goes on and off during one ignition cycle. Error codes are not stored. When the key is turned OFF, the code and message is lost, but will reappear if the fault reoccurs after restarting the engine.

If the CHECK ENGINE lamp or the EPS lamp illuminates, retrieve the active error codes from the display.

- ① Failure Mode Indicator (FMI)
- ② Suspect Parameter Number (SPN)
- ③ Code Count

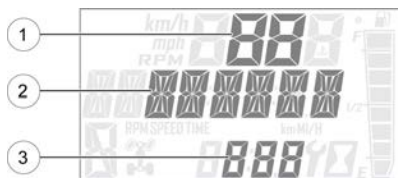

1. Press and hold the MODE button to enter the settings menu.
2. Press either toggle button to cycle to the “DIAGCODE” option. Press MODE to select.
3. More than one diagnostic code may be present. Press the toggle UP button to see if more codes are present. Press MODE to select a code.

#### NOTE

If the displayed code is an engine fault code, the CHECK ENGINE lamp will blink. If the displayed code is an EPS fault code, the EPS lamp will blink.

4. Record the three (3) numbers displayed.
5. Press MODE to exit to the settings menu.

## DIAGNOSTIC DISPLAY CODE DEFINITIONS

**Open Load:** There is a break in the wires that lead to the item listed in the chart (injector, fuel pump, etc.), or the item has failed.

**Short-to-Ground:** The wire is shorted to ground between the electronic control unit and the item listed in the chart.

**Shorted Load:** The wires leading to the item listed in the chart are shorted together, or the item has shorted internally.

**Short-to-Battery:** The wire leading from the item listed in the chart to the electronic control unit is shorted to a wire at battery voltage.

DIAGNOSTIC CODES			
COMPONENT	CONDITION	SPN	FMI
<b>Engine Control Module</b>			
Accelerator Position 2	Voltage Above Normal, Or Shorted To High Source	29	3
	Voltage Below Normal, Or Shorted To Low Source		4
Throttle Position Sensor 1	Voltage Above Normal, Or Shorted To High Source	51	3
	Voltage Below Normal, Or Shorted To Low Source		4
Vehicle Speed Sensor	Data Erratic, Intermittent Or Incorrect	84	2
Accelerator Position 1	Voltage Above Normal, Or Shorted To High Source	91	3
	Voltage Below Normal, Or Shorted To Low Source		4
	Voltage Above Normal, Or Shorted To High Source		3
	Voltage Below Normal, Or Shorted To Low Source		4
Manifold Absolute Pressure Sensor	Voltage Above Normal, Or Shorted To High Source	102	3
	Voltage Below Normal, Or Shorted To Low Source		4

## FEATURES AND CONTROLS

DIAGNOSTIC CODES			
COMPONENT	CONDITION	SPN	FMI
Intake Air Temperature Sensor	Data Valid But Above Normal Operational Range - Most Severe Level	105	0
	Voltage Above Normal, Or Shorted To High Source		3
	Voltage Below Normal, Or Shorted To Low Source		4
Barometric Pressure Sensor	Voltage Above Normal, Or Shorted To High Source	108	3
	Voltage Below Normal, Or Shorted To Low Source		4
Engine Temperature Sensor	Data Valid But Above Normal Operational Range - Most Severe Level	110	0
	Data Erratic, Intermittent Or Incorrect		2
	Voltage Above Normal, Or Shorted To High Source		3
	Voltage Below Normal, Or Shorted To Low Source		4
	Abnormal Rate Of Change		10
	Data Valid But Above Normal Operating Range - Moderately Severe Level		16
Fuel Rail Pressure Sensor	Data Erratic, Intermittent Or Incorrect	157	2
	Voltage Above Normal, Or Shorted To High Source		3
	Voltage Below Normal, Or Shorted To Low Source		4
	Data Valid But Above Normal Operating Range - Least Severe Level		15



## FEATURES AND CONTROLS

<b>DIAGNOSTIC CODES</b>			
<b>COMPONENT</b>	<b>CONDITION</b>	<b>SPN</b>	<b>FMI</b>
	Data Valid But Below Normal Operating Range - Least Severe Level		17
	Data Valid But Below Normal Operational Range - Most Severe Level		1
	Data Erratic, Intermittent Or Incorrect		2
	Voltage Above Normal, Or Shorted To High Source		3
	Voltage Below Normal, Or Shorted To Low Source		4
	Data Valid But Below Normal Operating Range - Moderately Severe Level		18
Engine Speed	Condition Exists	190	31
Gear Sensor Signal	Data Erratic, Intermittent Or Incorrect	523	2
Crankshaft Position Sensor	Data Erratic, Intermittent Or Incorrect	636	2
Injector 1 (Front) (MAG) (SDI Port Injector)	Voltage Above Normal, Or Shorted To High Source	651	3
	Voltage Below Normal, Or Shorted To Low Source		4
	Current Below Normal Or Open Circuit		5
Injector 2 (Rear) (PTO) (SDI Port Injector)	Voltage Above Normal, Or Shorted To High Source	652	3
	Voltage Below Normal, Or Shorted To Low Source		4
	Current Below Normal Or Open Circuit		5

## FEATURES AND CONTROLS

DIAGNOSTIC CODES			
COMPONENT	CONDITION	SPN	FMI
Starter Solenoid Driver Circuit	Voltage Above Normal, Or Shorted To High Source	677	3
	Voltage Below Normal, Or Shorted To Low Source		4
	Current Below Normal Or Open Circuit		5
Knock Sensor 1	Data Valid But Below Normal Operational Range - Most Severe Level	731	1
Fan Relay Driver Circuit	Voltage Above Normal, Or Shorted To High Source	1071	3
	Voltage Below Normal, Or Shorted To Low Source		4
	Current Below Normal Or Open Circuit		5
Boost Pressure Sensor	Data Valid But Above Normal Operational Range - Most Severe Level	1127	0
	Data Erratic, Intermittent Or Incorrect		2
	Voltage Above Normal, Or Shorted To High Source		3
	Voltage Below Normal, Or Shorted To Low Source		4
	Condition Exists		31
Ignition Coil Primary Driver 1 (Front) (MAG)	Voltage Above Normal, Or Shorted To High Source	1268	3
Ignition Coil Primary Driver 2 (Rear) (PTO)	Voltage Above Normal, Or Shorted To High Source	1269	3
PWM Fuel Pump	Voltage Above Normal, Or Shorted To High Source	1347	3

## FEATURES AND CONTROLS

<b>DIAGNOSTIC CODES</b>			
<b>COMPONENT</b>	<b>CONDITION</b>	<b>SPN</b>	<b>FMI</b>
	Voltage Below Normal, Or Shorted To Low Source		4
	Current Below Normal Or Open Circuit		5
Fuel Pump Module Errors	Abnormal Frequency Or Pulse Width Or Period		8
	Voltage Below Normal, Or Shorted To Low Source		4
Oxygen Sensor Bank 1 Sensor 1	Data Erratic, Intermittent Or Incorrect	3056	2
	Voltage Above Normal, Or Shorted To High Source		3
	Voltage Below Normal, Or Shorted To Low Source		4
	Bad Intelligent Device Or Component		12
ECU Output Supply Voltage 1	Voltage Above Normal, Or Shorted To High Source	3597	3
	Voltage Below Normal, Or Shorted To Low Source		4
ECU Output Supply Voltage 2	Voltage Above Normal, Or Shorted To High Source	3598	3
	Voltage Below Normal, Or Shorted To Low Source		4
ECU Output Supply Voltage 3	Voltage Above Normal, Or Shorted To High Source	3599	3
	Voltage Below Normal, Or Shorted To Low Source		4
Cylinder Misfire	Mechanical System Not Responding Or Out Of Adjustment	65590	7

## FEATURES AND CONTROLS

DIAGNOSTIC CODES			
COMPONENT	CONDITION	SPN	FMI
Cylinder 1 Misfire	Mechanical System Not Responding Or Out Of Adjustment	65591	7
Cylinder 2 Misfire	Mechanical System Not Responding Or Out Of Adjustment	65592	7
ETC Accelerator Position Sensor Outputs 1 & 2 Correlation	Data Erratic, Intermittent Or Incorrect	65613	2
Fuel Pump Controller	Abnormal Frequency Or Pulse Width Or Period	66028	8
	Bad Intelligent Device Or Component		12
Throttle Position Sensor 2	Voltage Above Normal, Or Shorted To High Source	520198	3
	Voltage Below Normal, Or Shorted To Low Source		4
Canister Purge Valve	Voltage Above Normal, Or Shorted To High Source	520202	3
	Voltage Below Normal, Or Shorted To Low Source		4
	Current Below Normal Or Open Circuit		5
All Wheel Drive Control Circuit	Voltage Above Normal, Or Shorted To High Source	520207	3
	Voltage Below Normal, Or Shorted To Low Source		4
	Current Below Normal Or Open Circuit		5
Chassis Relay	Voltage Above Normal, Or Shorted To High Source	520208	3

## FEATURES AND CONTROLS

<b>DIAGNOSTIC CODES</b>			
<b>COMPONENT</b>	<b>CONDITION</b>	<b>SPN</b>	<b>FMI</b>
	Voltage Below Normal, Or Shorted To Low Source		4
	Current Below Normal Or Open Circuit		5
Oxygen Sensor Heater 1	Data Erratic, Intermittent Or Incorrect	520209	2
	Voltage Above Normal, Or Shorted To High Source		3
	Voltage Below Normal, Or Shorted To Low Source		4
	Current Below Normal Or Open Circuit		5
Accelerator Position/Brake Position Interaction	Condition Exists	520275	31
Throttle Position Sensor (1 or 2 Indeterminable)	Data Erratic, Intermittent Or Incorrect	520276	2
	Bad Intelligent Device Or Component		12
Throttle Body Control - Power Stage	Data Erratic, Intermittent Or Incorrect	520277	2
	Voltage Above Normal, Or Shorted To High Source		3
	Voltage Below Normal, Or Shorted To Low Source		4
	Abnormal Frequency Or Pulse Width Or Period		8
Throttle Body Control - Adaption Aborted	Condition Exists	520279	31

## FEATURES AND CONTROLS

DIAGNOSTIC CODES			
COMPONENT	CONDITION	SPN	FMI
Throttle Body Control - Limp Home Position Check Failed	Condition Exists	520280	31
Throttle Body Control - Mechanical Stop Adaptation Failure	Condition Exists	520281	31
Throttle Body Control - Repeated Adaptation Failed	Condition Exists	520282	31
Throttle Body Control	Voltage Above Normal, Or Shorted To High Source	520283	3
	Voltage Below Normal, Or Shorted To Low Source		4
Throttle Body Control - Position Deviation Fault	Condition Exists	520284	31
Brake Switch (1 or 2 Indeterminable)	Data Erratic, Intermittent Or Incorrect	520285	2
ECU Monitoring Error	Condition Exists	520286	31
ECU Monitoring Error (Level 3)	Condition Exists	520287	31
ECU Monitoring of Injection Cut Off (Level 1)	Condition Exists	520288	31
ECU Monitoring of Injection Cut Off (Level 2)	Condition Exists	520289	31
Throttle Body Control - Requested Throttle Angle Not Plausible	Condition Exists	520305	31

## FEATURES AND CONTROLS

<b>DIAGNOSTIC CODES</b>			
<b>COMPONENT</b>	<b>CONDITION</b>	<b>SPN</b>	<b>FMI</b>
ECU ADC Fault - No Load	Condition Exists	520306	31
ECU ADC Fault - Voltage	Condition Exists	520307	31
Accelerator Sensor Sync Fault - Sensor Diff Exceeds Limit	Condition Exists	520308	31
ECU Fault - ICO	Condition Exists	520309	31
ECU Fault - Hardware Disruption	Condition Exists	520311	31
Knock Sensor Positive Line	Voltage Above Normal, Or Shorted To High Source	520331	3
	Voltage Below Normal, Or Shorted To Low Source		4
Knock Sensor Negative Line	Voltage Above Normal, Or Shorted To High Source	520332	3
	Voltage Below Normal, Or Shorted To Low Source		4
ECU Monitoring (Pedal Map Mismatch)	Condition Exists	520336	31
Wastegate Solenoid Driver	Voltage Above Normal, Or Shorted To High Source	520341	3
	Voltage Below Normal, Or Shorted To Low Source		4
	Current Below Normal Or Open Circuit		5
Adaptive Fuel Correction Bank 1	Data Valid But Above Normal Operating Range - Least Severe Level	520344	15
	Data Valid But Below Normal Operating Range - Least Severe Level		17

## FEATURES AND CONTROLS

<b>DIAGNOSTIC CODES</b>			
<b>COMPONENT</b>	<b>CONDITION</b>	<b>SPN</b>	<b>FMI</b>
Intercooler Pump Driver Circuit	Voltage Above Normal, Or Shorted To High Source	520496	3
	Voltage Below Normal, Or Shorted To Low Source		4
	Current Below Normal Or Open Circuit		5
pWideband Oxygen Sensor Bank 1 Sensor 1 Pumping Current Trim	Current Below Normal Or Open Circuit	520612	5
pWideband Oxygen Sensor Bank 1 Sensor 1 Positive Current Control	Current Below Normal Or Open Circuit	520613	5
pWideband Oxygen Sensor Bank 1 Sensor 1 Negative Current Control	Current Below Normal Or Open Circuit	520614	5
pWideband Oxygen Sensor Bank 1 Sensor 1 Reference Voltage	Current Below Normal Or Open Circuit	520615	5
pWideband Chip	Bad Intelligent Device Or Component	520679	12
Start Switch	Data Erratic, Intermittent Or Incorrect	521083	2
<b>EPAS Module</b>			
Steering Over Current Shut Down	Current Above Normal Or Grounded Circuit	520221	6
Steering Excessive Current Error	Current Above Normal Or Grounded Circuit	520222	6
Steering Torque Partial Failure	Condition Exists	520223	31



## FEATURES AND CONTROLS

<b>DIAGNOSTIC CODES</b>			
<b>COMPONENT</b>	<b>CONDITION</b>	<b>SPN</b>	<b>FMI</b>
Steering Torque Full Failure	Condition Exists	520224	31
EPAS Inverter Temperature	Data Valid But Above Normal Operational Range - Most Severe	520225	0
	Data Valid But Above Normal Operating Range - Severe		16
EPAS Communications Receive Data Error	Data Erratic, Intermittent Or Incorrect	520226	2
	Condition Exists	520226	31
Position Encoder Error	Root Cause Not Known	520228	11
	Bad Intelligent Device Or Component	520228	12
	Condition Exists	520228	31
EPAS Software Error	Bad Intelligent Device Or Component	520229	12
	Condition Exists	520229	31
EPAS Power Save Condition	Condition Exists	520231	31
EPS SEPIC Voltage Error	Voltage Above Normal, Or Shorted To High Source	524086	3
	Voltage Below Normal, Or Shorted To Low Source	524086	4
Calibration CRC	Checksum/CRC Error	630	13
Steering Torque Full Failure	Torque Sensor Out of Range	520223	31
	Torque Sensor Linearity Error	520224	31
EPS CAN Communications Receive Error	No RX Message for {{cal parameter}} seconds	520226	2
Vehicle Speed	Vehicle Speed Too High	84	0

## FEATURES AND CONTROLS

DIAGNOSTIC CODES			
COMPONENT	CONDITION	SPN	FMI
	Vehicle Speed Implausible		10
	Received Vehicle Speed has Errors		19
Engine Speed	Engine Speed Too High	190	0
	Received Engine Speed has Errors	190	19
Battery Voltage	Too High	168	3
Battery Voltage	Too Low	168	4

## FEATURES AND CONTROLS

<b>DIAGNOSTIC CODES</b>			
<b>COMPONENT</b>	<b>CONDITION</b>	<b>SPN</b>	<b>FMI</b>
Position Encoder Error	Loss of SPI Communication	520228	12
	Encoder Variance Error		31
EPS Software Error	Manufacturing CRC Error	520229	12
	Boot Count Error		31
ICS Communication	Loss of CAN between EPS and Instrument Cluster	520230	31
EPAS Power Save	5 minute time out	520231	31
ECU Memory	EEPROM Communication Error	628	12
	Application CRC Error		13
VGD Low	VGD Low	524086	4
Absolute Position Sensor	Absolute Position Sensor Out of Range	1807	31
	Absolute Position Sensor Not Calibrated	1807	13

## FEATURES AND CONTROLS

DIAGNOSTIC CODES			
COMPONENT	CONDITION	SPN	FMI
<b>Suspension Control Module</b>			
Vehicle Speed Sensor	Data Drifted High	84	20
	Data Drifted Low		21
Transmission Requested Range Data	Data Erratic, Intermittent Or Incorrect	162	2
Suspension Mode Switch Input	Data Erratic, Intermittent Or Incorrect	516098	2
	Voltage Above Normal, Or Shorted To High Source		3
	Voltage Below Normal, Or Shorted To Low Source		4
Valve Driver Front Left	Voltage Above Normal, Or Shorted To High Source	516106	3
	Voltage Below Normal, Or Shorted To Low Source		4
Valve Driver Front Right	Voltage Above Normal, Or Shorted To High Source	516107	3
	Voltage Below Normal, Or Shorted To Low Source		4
Valve Driver Rear Left	Voltage Above Normal, Or Shorted To High Source	516108	3
	Voltage Below Normal, Or Shorted To Low Source		4
Valve Driver Rear Right	Voltage Above Normal, Or Shorted To High Source	516109	3
	Voltage Below Normal, Or Shorted To Low Source		4

## FEATURES AND CONTROLS

<b>DIAGNOSTIC CODES</b>			
<b>COMPONENT</b>	<b>CONDITION</b>	<b>SPN</b>	<b>FMI</b>
Shock Valve Power Supply Relay Driver	Voltage Above Normal, Or Shorted To High Source	516110	3
	Voltage Below Normal, Or Shorted To Low Source		4
Absolute Shock Current Error - Front Left	Root Cause Not Known	516111	11
Absolute Shock Current Error - Front Right	Root Cause Not Known	516112	11
Absolute Shock Current Error - Rear Left	Root Cause Not Known	516113	11
Absolute Shock Current Error - Rear Right	Root Cause Not Known	516114	11
Internal Inertial Measurement Unit	Bad Intelligent Device Or Component	516115	12
	Data Valid But Above Normal Operating Range - Least Severe Level		15
	Data Valid But Below Normal Operating Range - Least Severe Level		17

## FEATURES AND CONTROLS

DIAGNOSTIC CODES			
COMPONENT	CONDITION	SPN	FMI
CAN Message PGN 65382	Abnormal Update Rate	516116	9
CAN Message PGN 65396	Abnormal Update Rate	516117	9
CAN Message PGN 65314	Abnormal Update Rate	516118	9
SW Version & HW Version Mismatch	Data Erratic, Intermittent Or Incorrect	516119	2
CAN Message PGN 65265	Abnormal Update Rate	516120	9
CAN Message PGN 61445	Abnormal Update Rate	516121	9
Steering Angle Adoption Offset	Data Valid But Above Normal Operating Range - Least Severe Level	516122	15
Vehicle Speed Data	Data Erratic, Intermittent Or Incorrect	516123	2
	Data Drifted High		20
Suspension Control Module	Bad Intelligent Device Or Component	516124	12
CAN 1	Root Cause Not Known	516125	11

## FEATURES AND CONTROLS

<b>DIAGNOSTIC CODES</b>			
<b>COMPONENT</b>	<b>CONDITION</b>	<b>SPN</b>	<b>FMI</b>
System Voltage	Data Valid But Above Normal Operational Range - Most Severe Level	516126	0
	Data Valid But Below Normal Operational Range - Most Severe Level		1
	Voltage Above Normal, Or Shorted To High Source		3
	Voltage Below Normal, Or Shorted To Low Source		4
	Data Valid But Above Normal Operating Range - Moderately Severe Level		16
	Data Valid But Below Normal Operating Range - Moderately Severe Level		18
Raw Brake Switch Status	Data Erratic, Intermittent Or Incorrect	520572	2
Normalized Accelerator Pedal Position	Data Erratic, Intermittent Or Incorrect	520574	2
Engine Speed Data	Data Erratic, Intermittent Or Incorrect	524000	2
Steering Angle Input	Data Erratic, Intermittent Or Incorrect	524114	2





---

## OPERATION

### IMPORTANT INFORMATION

** WARNING**

Failure to operate the vehicle properly can result in a collision, loss of control, accident or rollover, which may result in serious injury or death. Read and understand all safety warnings outlined in the safety section of this owner's manual.

### VEHICLE BREAK-IN PERIOD

The break-in period for your new POLARIS vehicle is the first 25 hours of operation, or the time it takes to use the first two tanks full of gasoline. Clutch and drive belt break-in periods vary depending on operating conditions.

No single action on your part is as important as a proper break-in period. Careful treatment of a new engine and drive components will result in more efficient performance and longer life for these components. Perform the following procedures carefully.

**NOTICE**

Excessive heat build-up during the first three hours of operation will damage close-fitted engine parts and drive components. Do not operate at full throttle or high speeds during the first three hours of use.

Use of any improper oils may cause serious engine damage. POLARIS Premium 4 Synthetic Oil is specifically formulated for your 4-cycle engine

# OPERATION

---

## ENGINE AND DRIVETRAIN BREAK-IN

1. Fill the fuel tank with the recommended fuel. See the Refueling section for details. Always exercise extreme caution whenever handling gasoline.
2. Check the oil level. See the Oil Check section for details. Add the recommended oil as needed to maintain the oil level in the safe operating range.
3. Complete the steps in the New Operator Driving Procedures section.
4. Avoid aggressive use of the brakes.
5. Vary throttle positions. Do not operate at sustained idle.
6. Perform regular checks on fluid levels, controls and areas outlined on the daily pre-ride inspection checklist.
7. Carry only light loads.
8. During the break-in period, change both the oil and the filter at 25 hours or one month.
9. Check fluid levels of transmission and all gearcases after the first 25 hours of operation and every 100 hours thereafter.

## BRAKE SYSTEM BREAK-IN

Apply only moderate braking force for the first 50 stops. Aggressive or overly forceful braking when the brake system is new could damage brake pads and rotors.

## PVT BREAK-IN (CLUTCHES / BELT)

A proper break-in of the clutches and drive belt will ensure a longer life and better performance. If a belt fails, always clean any debris from the duct and from the engine compartment.

### *Standard Break-in*

Drive at slower speeds for the first 50 miles (80 km) of operation. Carry only light loads. Avoid aggressive acceleration, high-speed operation and prolonged operation at a specific RPM during this period.

### *Sand / Dune Break-in*

Drive in low gear for the first 5 miles (8 km) of operation. Avoid prolonged low speed operation at high throttle. Avoid aggressive acceleration, high-speed operation and prolonged operation at a specific RPM during this period.

## PRE-RIDE INSPECTION

Failure to inspect and verify that the vehicle is in safe operating condition before operating increases the risk of an accident. Always inspect the vehicle before each use to make sure it's in safe operating condition.

ITEM	REMARKS	REF
Brake system/pedal travel	Ensure proper operation	page 49 page 171
Brake fluid	Ensure proper level	page 173
Front suspension	Inspect, lubricate if necessary	page 141
Rear suspension	Inspect, lubricate if necessary	page 141
Steering	Ensure free operation	page 184
Tires	Inspect condition and pressure	page 16 page 179
Wheels/fasteners	Inspect, ensure fastener tightness	page 180
Frame nuts, bolts, fasteners	Inspect, ensure tightness	–
Fuel and oil	Ensure proper levels	page 144
Coolant level	Ensure proper level	page 158
Coolant hoses	Inspect for leaks	–
Throttle	Ensure proper operation	–
Indicator lights/ switches	Ensure proper operation	page 52
Air Filter	Inspect, replace as needed	page 167
Engine intake pre-filter	Inspect, clean	page 166
PVT intake pre-filter	Inspect, clean	page 162
Headlights	Check operation	–
Brake light/taillight	Check operation	–
Seat Latches	Push down on both seat backs to ensure the latches are secure	page 38

## OPERATION

ITEM	REMARKS	REF
Seat Belts	Check length of belt for damage, check latches for proper operation	page 44
Cab Doors	Check doors and latches for wear or damage.	page 22
Exhaust	Inspect spark arrester and clean if needed after riding through water and/or mud.	page 169
Grass and leaves	Remove grass, leaves, and other flammable material or debris, especially near the exhaust system.	-

---

## SAFE OPERATION PRACTICES

1. Visit the Recreational Off-Highway Vehicle Association web site ([rohva.org](http://rohva.org)) and take the free on-line training course. Complete the steps in the New Operator Driving Procedures section.
2. Do not allow anyone under 16 years of age or without a valid driver's license to operate this vehicle.
3. Never carry a passenger on a 1-seat vehicle. Never carry more than one passenger in a 2-seat vehicle. Never carry more than three passengers in a 4-seat vehicle. Never allow a passenger to ride in the cargo box.
4. Engine exhaust fumes are poisonous. Never start the engine or let it run in an enclosed area.
5. Never operate with accessories not approved by POLARIS for use on this vehicle.
6. Operate this vehicle off-road only. Never operate the vehicle on pavement or on any public street, road or highway, including dirt and gravel roads.
7. Drive in a manner appropriate for your skills and operating conditions. Never operate at excessive speeds. Never attempt wheelies, jumps, or other stunts. Keep both hands on the steering wheel during operation.
8. Never consume alcohol or drugs before or while operating this vehicle.
9. Always use the size and type of tires specified for your vehicle. Always maintain proper tire pressure.
10. Never operate a damaged vehicle. After any rollover or accident, have a qualified service dealer inspect the entire machine for possible damage.
11. Never operate the vehicle on a frozen body of water unless you have first verified that the ice is sufficiently thick to support the weight and moving force of the vehicle, you and your passengers, and your cargo, together with any other vehicles in your party.
12. Do not touch hot exhaust system components. Always keep combustible materials away from the exhaust system.
13. Always remove the ignition key when the vehicle is not in use to prevent unauthorized use.
14. Do not store items between the seat and the cargo box. Items wedged in this space could affect vehicle components.

### STARTING THE ENGINE

#### NOTICE

Operating the vehicle immediately after starting could cause engine damage. Allow the engine to warm up for several minutes before operating the vehicle.

1. Position the vehicle on a level surface outdoors or in a well-ventilated area.
2. Sit in the driver's seat and fasten the seat belt. Always make sure all cab doors are closed and latched when riding in this vehicle.
3. Place the transmission in PARK.
4. Apply the brakes. Do not press the throttle pedal while starting the engine.
5. Turn the ignition key past the ON/RUN position and release immediately to START. The engine will turn over for a maximum five seconds until the vehicle has started.
6. If the engine does not start within five seconds, return the ignition switch to the OFF position and wait five seconds. Repeat steps 5 and 6 until the engine starts.
7. After starting the engine, wait 10 seconds before applying throttle.

### STOPPING THE ENGINE

#### WARNING

A rolling vehicle can cause serious injury. Always place the transmission in PARK and engage the park brake (if equipped) when stopping the engine.

1. Release the throttle pedal completely and brake to a complete stop.
2. Place the transmission in PARK.
3. Turn the engine off.
4. Slowly release the brake pedal and make sure the transmission is in PARK before exiting the vehicle.
5. Engage the park brake (if equipped).

---

## BRAKING

1. Release the throttle pedal completely.

### TIP

When the throttle pedal is released completely and engine speed slows to near idle, the vehicle has no engine braking.

2. Press on the brake pedal evenly and firmly.
3. Practice starting and stopping (using the brakes) until you're familiar with the controls.

## PARKING THE VEHICLE

1. Stop the vehicle on a level surface. When parking inside a garage or other structure, be sure that the structure is well ventilated and that the vehicle is not close to any source of flame or sparks, including any appliance with pilot lights.
2. Place the transmission in PARK.
3. Stop the engine.
4. Slowly release the brake pedal and make sure the transmission is in PARK before exiting the vehicle.
5. Engage the park brake (if equipped).
6. Remove the ignition key to prevent unauthorized use.

## KNOW YOUR RIDING AREA / TREAD LIGHTLY

Familiarize yourself with all laws and regulations concerning the operation of this vehicle in your area. Respect the environment in which you ride your vehicle. Find out where the designated riding areas are by contacting your POLARIS dealer, a local riding club, or local officials.

Help keep our trails open for recreational vehicle use. As an off-road enthusiast, you represent the sport and can set a good example (or a poor example) for others to follow. Tread lightly. Operate with respect for the terrain, avoid littering, and always stay on the designated trails.

## NEW OPERATOR DRIVING PROCEDURES

1. Read and understand the owner's manual and all warning and instruction labels before operating this vehicle.
2. Visit the Recreational Off-Highway Vehicle Association web site ([rohva.org](http://rohva.org)) and take the free on-line training course. Hands-on training is also available through ROHVA.

## OPERATION

---

3. Perform the pre-ride inspection.
4. Do not carry a passenger until you have at least two hours of driving experience with this vehicle.
5. Do not carry cargo during this period.
6. Select an open area that allows room to familiarize yourself with vehicle operation and handling.
7. The driver and all passengers must wear helmet, eye protection, gloves, long-sleeve shirt, long pants, over-the-ankle boots and seat belt at all times.
8. Always make sure all cab doors are closed and latched when riding in this vehicle.
9. Sit in the driver's seat and fasten the seat belt.
10. Place the transmission in PARK.
11. Start the engine.
12. Apply the brakes and shift into low gear.
13. Check your surroundings and determine your path of travel.
14. Keeping both hands on the steering wheel, slowly release the brakes and depress the throttle with your right foot to begin driving.
15. Drive slowly at first. On level surfaces, practice starting, stopping, turning, maneuvering, using the throttle and brakes and driving in reverse. Learn how the vehicle handles when making both left and right turns at a slow speed.
16. Increase speed only after mastering all maneuvers at a slow speed.
17. After you become skilled at making turns and begin to operate at faster speeds, follow these precautions:
  - Avoid sharp turns.
  - Never turn while applying heavy throttle.
  - Never make abrupt steering maneuvers.
  - Operate at speeds appropriate for your skills, the conditions and the terrain.
  - DO NOT do power slides, "donuts", jumps or other driving stunts.

## TRAIL ETIQUETTE

Always practice good etiquette when riding. Allow a safe distance between your vehicle and other vehicles operating in the same area. Communicate to oncoming operators by signaling the number of vehicles in your group. When stopping, move your vehicle to the edge of the trail as far as possible to allow others to pass safely.



---

## DRIVING WITH PASSENGERS

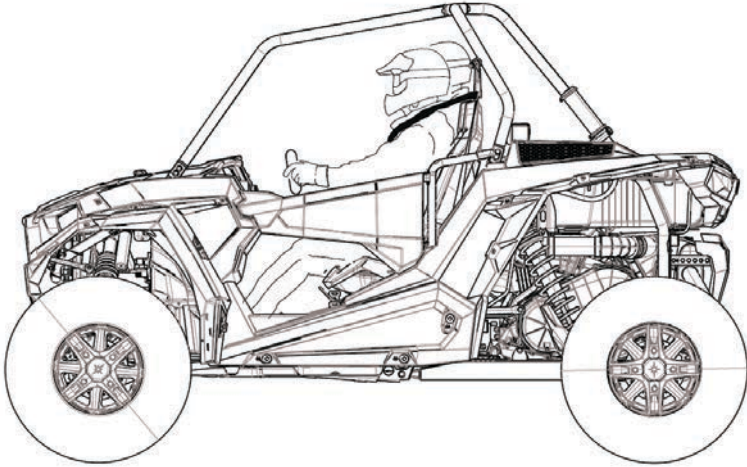

1. Complete the steps in the New Operator Driving Procedures section.
2. Perform the pre-ride inspection.
3. Do not carry more than one passenger in a 2-seat vehicle. Do not carry more than three passengers in a 4-seat vehicle. Additional passengers can affect the operator's ability to steer and operate the controls.
4. All riders must be able to sit with backs against the seat, both feet flat on the floor and both hands on the steering wheel (if driving) or on a passenger hand hold.
5. The driver and all passengers must wear helmet, eye protection, gloves, long-sleeve shirt, long pants, over-the-ankle boots and seat belt at all times. See the Safe Riding Gear section for details.
6. Always make sure all cab doors are closed and latched when riding in this vehicle.
7. Allow a passenger to ride only in a passenger seat.
8. Slow down. Always travel at a speed appropriate for your skills, your passengers' skills and operating conditions. Avoid unexpected or aggressive maneuvers that could cause discomfort or injury to a passenger.
9. Vehicle handling may change with passengers and/or cargo on board. Allow more time and distance for braking.
10. Always follow all operating guidelines as outlined on safety labels and in this manual.

### DRIVING ON SLIPPERY SURFACES

When driving on slippery surfaces such as wet trails, loose gravel, or ice, be alert for the possibility of skidding and sliding.

Follow these precautions when encountering slippery conditions:

1. Slow down before entering slippery areas.
2. Maintain a high level of alertness, reading the trail and avoiding quick, sharp turns, which can cause skids.
3. Engage all-wheel drive before wheels begin to lose traction.

#### NOTICE

Severe damage to the drive train may occur if the AWD is engaged while the wheels are spinning. Always allow the wheels to stop spinning before engaging AWD.

4. Correct a skid by turning the steering wheel in the direction of the skid. *Never apply the brakes during a skid.*

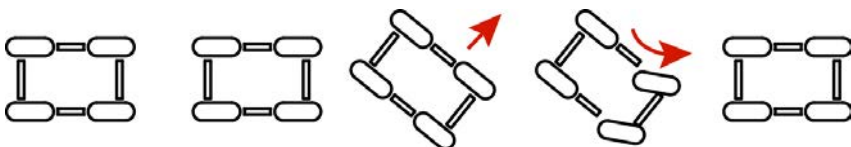

---

## DRIVING UPHILL

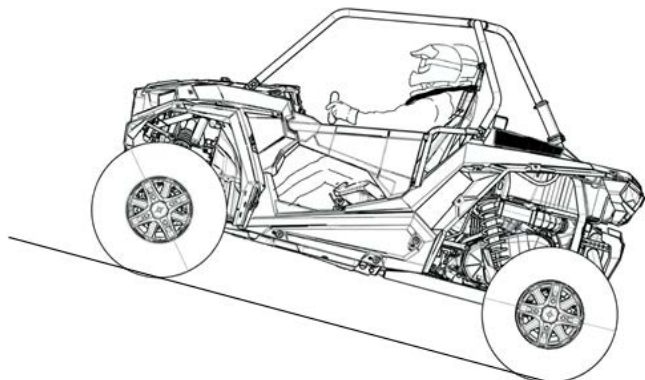

Whenever traveling uphill, follow these precautions:

1. Always check the terrain carefully before ascending a hill. Never drive on hills with excessively slippery or loose surfaces.
2. Avoid excessively steep hills. If ascending a steeper grade is unavoidable, engage all-wheel drive before ascending.
3. Drive straight uphill.
4. Proceed at a steady rate of speed and throttle opening. Never open the throttle suddenly.
5. Avoid unnecessary changes in speed or direction.
6. Never go over the crest of a hill at high speed. An obstacle, a sharp drop, or another vehicle or person could be on the other side of the hill.
7. If the vehicle stalls while climbing a hill, apply the brakes. Place the transmission in reverse and slowly allow the vehicle to roll straight downhill while applying light brake pressure to control speed.

### **DRIVING ON A SIDEHILL (SIDEHILLING)**

Driving on a sidehill is not recommended. Improper procedure could cause loss of control or rollover. Avoid crossing the side of any hill unless absolutely necessary.

If crossing a hill is *unavoidable*, follow these precautions:

1. Engage all-wheel drive.
2. Never operate in TURF mode (if equipped) while operating on a hill or other irregular terrain. Always move the AWD switch to AWD before ascending or descending a hill.
3. Drive slowly and use extreme caution.
4. If the vehicle begins to roll over, or if it feels as if it may roll over, *immediately* turn downhill.
5. Avoid obstacles and changes in terrain that may lower or raise one side of the vehicle or cause the vehicle to slide.
6. If the vehicle begins to slide downhill, immediately turn downhill to stop the slide, or stop the vehicle and maneuver slowly and carefully until the vehicle can be driven straight downhill.

---

## DRIVING DOWNHILL

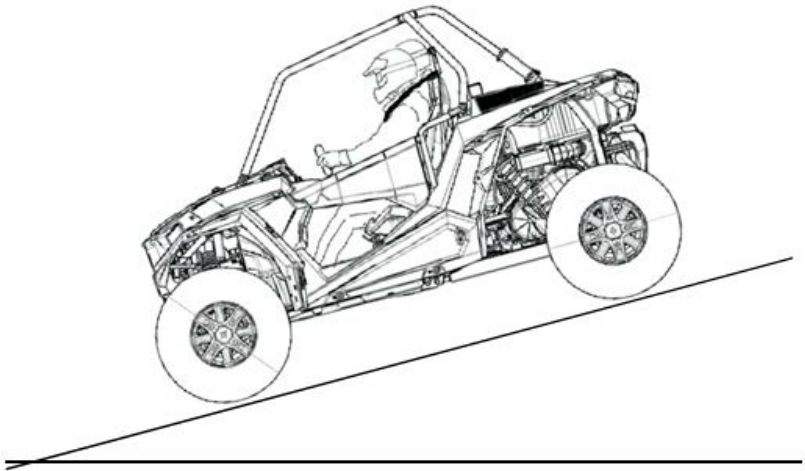

Whenever descending a hill, follow these precautions:

1. Avoid excessively steep hills.
2. Slow down. Never travel down a hill at high speed.
3. Always check the terrain carefully before descending a hill. Never drive on hills with excessively slippery or loose surfaces.
4. Always descend a hill with the transmission in forward gear. *Never descend a hill with the transmission in neutral.*
5. Avoid traveling down a hill at an angle, which would cause the vehicle to lean sharply to one side. Travel straight downhill.
6. Apply the brakes *lightly* to aid in slowing.

### DRIVING THROUGH WATER

#### WARNING

The large tires on your vehicle may cause the vehicle to float in deep or fast-flowing water, which could result in loss of traction, loss of control, rollover or accident.

#### NOTICE

Major engine damage can result if the vehicle is not thoroughly inspected after operation in water. Perform the services outlined in the Maintenance Chart section. Give special attention to engine oil, transmission oil, demand drive fluid, rear gearcase oil, and all grease fittings.

If your vehicle becomes immersed or is operated in water that exceeds the floor level, *service is required before starting the engine*. Your POLARIS dealer can provide this service. If it's impossible to bring the vehicle in before starting the engine, perform the service outlined on page 184, and take the vehicle in for service at the first opportunity.

Your vehicle can operate through water with a maximum recommended depth equal to floor level. Follow these precautions when operating through water:

1. Determine the water depth and current before entering the water.
2. Choose a crossing where the water level is lowest and where both banks have gradual inclines. Never operate in water that exceeds the maximum recommended depth (floor level) ①.
3. Wet brakes may have reduced stopping ability. After leaving water, test the brakes. Apply them lightly several times while driving slowly. The friction will help dry out the pads. Avoid applying brake and throttle at the same time.



---

## DRIVING OVER OBSTACLES

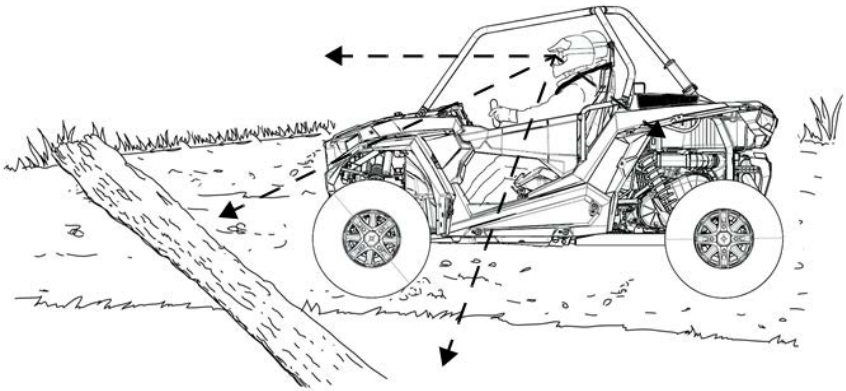

Follow these precautions when operating over obstacles:

1. Always check for obstacles before operating in a new area.
2. Look ahead and learn to read the terrain. Be constantly alert for hazards such as logs, rocks and low hanging branches.
3. Travel slowly and use extra caution when operating on unfamiliar terrain. Not all obstacles are immediately visible.
4. Avoid operating over large obstacles such as large rocks and fallen trees. If unavoidable, use extreme caution and operate slowly.
5. Always have all passengers dismount and move away from the vehicle before operating over an obstacle that could cause a rollover.

### DRIVING IN REVERSE

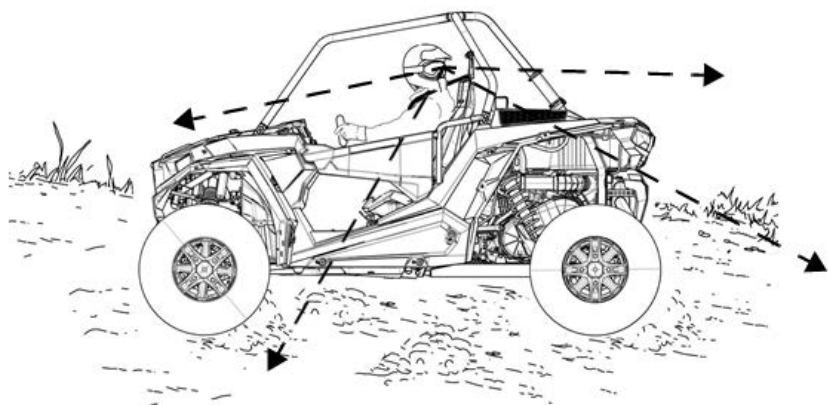

Follow these precautions when operating in reverse:

1. Always check for obstacles or people behind the vehicle.
2. Apply the throttle *lightly*. Never open the throttle suddenly.
3. Back slowly.
4. Apply the brakes *lightly* for stopping.
5. Avoid making sharp turns.



---

## PARKING ON AN INCLINE

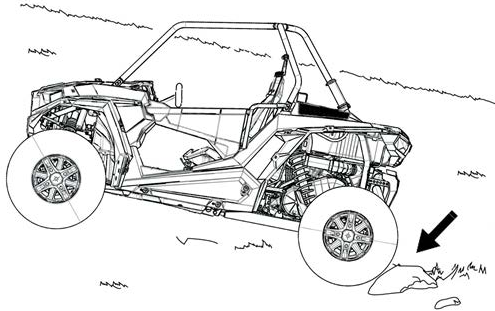

A rolling vehicle can result in serious injury. Avoid parking on an incline. If parking on an incline is *unavoidable*, follow these precautions:

1. Apply the brakes.
2. Place the transmission in PARK.
3. Stop the engine.
4. Slowly release the brake pedal and make sure the transmission is in PARK before exiting the vehicle.
5. Block the rear wheels on the downhill side.

## OPERATION

### HAULING CARGO

#### WARNING

NEVER carry fuel or other flammable liquids on this vehicle. Failure to follow this instruction could lead to serious burn injuries or death.

Overloading the vehicle or carrying cargo improperly can alter vehicle handling and may cause loss of control or brake instability. Always follow these precautions when hauling cargo:

Never exceed the stated load capacity for this vehicle.

REDUCE SPEED AND ALLOW GREATER DISTANCES FOR BRAKING  
WHEN HAULING CARGO.

NEVER EXCEED THE MAXIMUM WEIGHT CAPACITY of the vehicle. When determining the weight you are adding to the vehicle, include the weight of the operator, passengers, accessories and loads in the rack or box. The combined weight of these items must not exceed the maximum weight capacity.

Always load the cargo box with the load as far forward and as low as possible.

When operating over rough or hilly terrain, reduce speed and cargo to maintain stable driving conditions.

Always operate the vehicle with extreme care when hauling cargo. Slow down and drive in the lowest gear available.

#### WARNING

Carrying a passenger in the cargo box could result in a fall from the vehicle or contact with moving components. Never allow a passenger to ride in the cargo box. A passenger must always be seated in a passenger seat with seat belt secured.



 **WARNING**

**SECURE ALL LOADS BEFORE OPERATING.** Unsecured loads can create unstable operating conditions, which could result in loss of control of the vehicle.

**OPERATE ONLY WITH STABLE AND SAFELY ARRANGED LOADS.** When handling off-centered loads that cannot be centered, securely fasten the load and operate with extra caution.

**HEAVY LOADS CAN CAUSE BRAKING AND CONTROL PROBLEMS.** Use extreme caution when applying brakes with a loaded vehicle. Avoid terrain or situations that may require backing downhill.

**USE EXTREME CAUTION** when operating with loads that extend over the rack sides. Stability and maneuverability may be adversely affected, causing a rollover.

**DO NOT TRAVEL FASTER THAN THE RECOMMENDED SPEEDS.** Vehicle should never exceed 10 MPH (16 km/h) while cornering or while ascending or descending a hill.

Your POLARIS vehicle has been designed to carry a specific capacity. Reduce speed and allow a greater distance for braking when carrying cargo.

Loads should be centered and carried as low as possible in the box. For stability on rough or hilly terrain, reduce both speed and cargo. Exercise caution if the cargo load extends over the side of the box.

Always read and understand the load distribution warnings listed on warning labels and in this manual. Never exceed the maximum capacities specified for your vehicle.

## **BELT LIFE**

To extend belt life, use low gear in the following conditions:

- when hauling or towing heavy cargo.
- when consistently operating at speeds less than 35 MPH (56 km/h) in hard-pulling terrain, such as mud, rocks or sand/dune environments.

## OPERATION

### TOWING

#### WARNING

Towing improperly can alter vehicle handling and may cause loss of control or brake instability.

The tow loop ① on the rear of the vehicle is provided for recovery use ONLY. Tow a vehicle ONLY of equal or lesser size and weight.

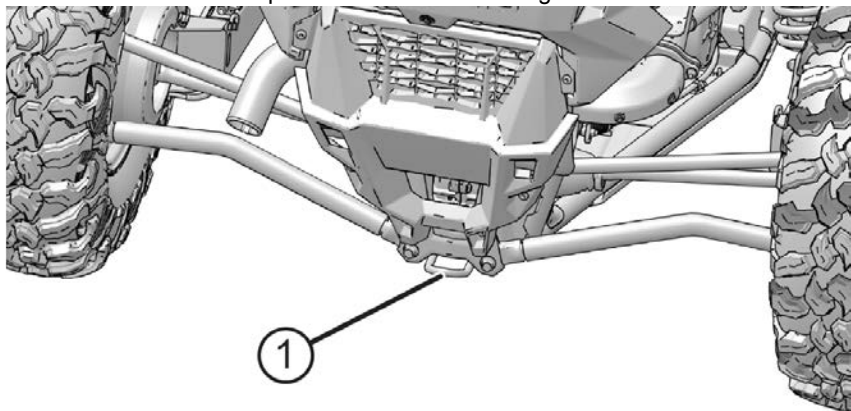

If preferred, the tow loop ② on the front of the vehicle is provided for recovery use ONLY as well. Tow a vehicle ONLY of equal or lesser size and weight.

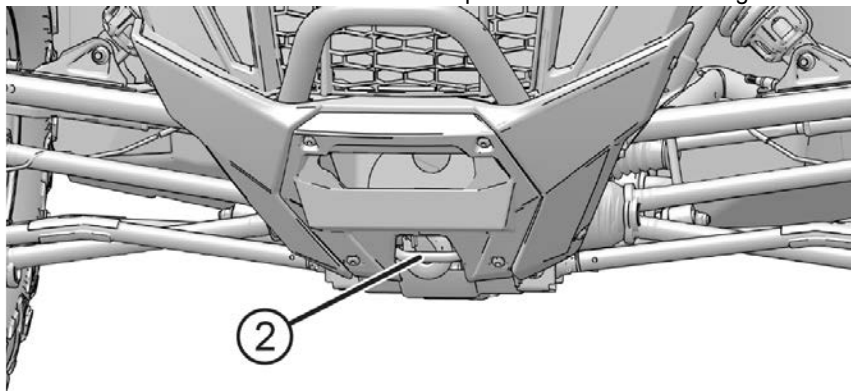

When towing a disabled *RZR* vehicle, place the disabled vehicle's transmission in neutral. Do not operate the vehicle faster than 10 MPH (16 km/h) when towing.

### **TOWING A RZR**

Towing this vehicle is not recommended. Always transport the vehicle on a trailer or flatbed with all four wheels off the ground. See the Transporting the Vehicle section for details.

If towing a disabled vehicle is unavoidable, place the disabled vehicle's transmission in neutral. Tow the shortest distance possible. Do not operate faster than 16 km/h (10 MPH).



---

## WINCH GUIDE

### WINCH SAFETY

These safety warnings and instructions apply if your vehicle came equipped with a winch or if you choose to add an accessory winch to your vehicle.

 **WARNING**

Improper winch use can result in SEVERE INJURY or DEATH. Always follow all winch instructions and warnings in this manual.

Your winch may have a cable made of either wire rope or specially designed synthetic rope. The term “winch cable” will be used for either unless noted otherwise.

### WINCH SAFETY PRECAUTIONS

1. Read all sections of this manual.
2. Never use alcohol or drugs before or while operating the winch.
3. Never allow children under 16 years of age to operate the winch.
4. Always wear eye protection and heavy gloves when operating the winch.
5. Always keep body, hair, clothing and jewelry clear of the winch cable, fairlead and hook when operating winch.
6. Never attempt to “jerk” a load attached to the winch with a moving vehicle. See the *Shock Loading* section on page 110.
7. Always keep the area around the vehicle, winch, winch cable, and load clear of people (especially children) and distractions while operating the winch.
8. Always turn the vehicle ignition power OFF when it and the winch are not being used.
9. Always be sure that at least five (5) full turns of winch cable are wrapped around the winch drum at all times. The friction provided by this wrapped cable allows the drum to pull on the winch cable and move the load.
10. Always apply your vehicle’s park brake and/or park mechanism to hold the vehicle in place during winching. Use wheel chocks if needed.
11. Always align the vehicle and winch with the load directly in front of the vehicle as much as possible. Avoid winching with the winch cable at an angle to the winching vehicle’s centerline whenever possible.

## WINCH GUIDE

---

12. If winching at an angle is unavoidable, follow these precautions:
  - a. Look at the winch drum occasionally. Never let the winch cable “stack” or accumulate at one end of the winch drum. Too much winch cable at one end of the winch drum can damage the winch and the winch cable.
  - b. If stacking occurs, stop winching. Follow step 15 of Winch Operation to feed and rewind the cable evenly before continuing the winch operation.
13. Never winch up or down at sharp angles. This can destabilize the winching vehicle and possibly cause it to move without warning.
14. Never attempt to winch loads that weigh more than the winch’s rated capacity.
15. The winch motor may become hot during winch use. If you winch for more than 45 seconds, or if the winch stalls during operation, stop winching and permit the winch to cool down for 10 minutes before using it again.
16. Never touch, push, pull or straddle the winch cable while winching a load.
17. Never let the winch cable run through your hands, even if wearing heavy gloves.



18. Never release the clutch on the winch when the winch cable is under load.
19. Never use the winch for lifting or transporting people.
20. Never use the winch to hoist or suspend a vertical load.
21. Always inspect your winch and winch cable before each use.



22. Never winch the hook fully into the winch. This can cause damage to winch components.
23. Unplug the remote control from the vehicle when the winch is not in use to prevent inadvertent activation and use by unauthorized persons.
24. Never grease or oil the winch cable. This will cause the winch cable to collect debris that will shorten the life of the cable.

### WINCH OPERATION

Read the Winch Safety Precautions in the preceding pages before using your winch.

#### TIP

Consider practicing the operation and use of your winch before you actually need to use it in the field.

#### WARNING

Improper winch use can result in SEVERE INJURY or DEATH. Always follow all winch instructions and warnings in this manual.

Each winching situation is unique.

- Take your time to think through the winching you are about to do.
  - Proceed slowly and deliberately.
  - Never hurry or rush during winching.
  - Always pay attention to your surroundings.
  - You may need to change your winching strategy if it is not working.
  - Always remember that your winch is very powerful.
  - There are simply some situations that you and your winch will not be able to deal with. Do not be afraid to ask others to help when this happens.
1. Always inspect the vehicle, winch, winch cable and winch controls for any signs of damage or parts in need of repair or replacement before each use. *Pay particular attention to the first 3 feet (1 meter) of winch cable if the winch is being used (or has been used) for lifting an accessory plow assembly.* Promptly replace any worn or damaged cable.
  2. Never operate a winch or a vehicle in need of repair or service.
  3. Always apply your vehicle's park brake and/ or park mechanism to hold the vehicle in place during winching. Use wheel chocks if needed.

4. Always use the hook strap when handling the hook.

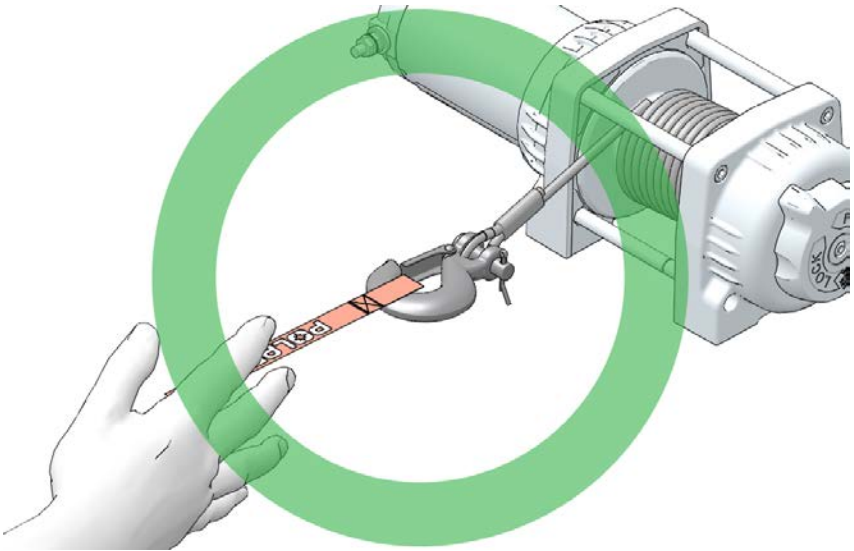

## ⚠ WARNING

Never put your fingers into the hook. This could lead to SEVERE INJURY.

- Attach the hook itself onto the load or use a tow strap or chain to secure the load to the winch cable.



## TIP

A “tow strap” is NOT intended to stretch. A “recovery strap” is designed to stretch.

## WINCH GUIDE

### WARNING

Never use a recovery strap when winching due to the excessive energy that can be released if the winch cable breaks. This can result in SEVERE INJURY or DEATH. See the *Shock Loading* section on page 110.

- Never hook the winch cable back onto itself. This will damage the winch cable and may result in winch cable failure.

### WARNING

Replace the winch cable at the first sign of damage to prevent SEVERE INJURY or DEATH in the event of failure. For your safety, always replace POLARIS winch parts (including the cable) with genuine POLARIS replacement parts available at your authorized POLARIS dealer, or other qualified dealer.

- If possible, keep the winch cable aligned with the centerline of the winching vehicle. This will help the spooling of the winch cable and reduce the load on the fairlead.
- If freeing a stuck vehicle by attaching to a tree, use an item such as a tow strap to avoid damaging the tree during winch operation. Sharp cables and chains can damage and even kill trees. Please remember to TreadLightly® ([treadlightly.org](http://treadlightly.org)).
- Before operating the winch, be sure that the safety latch on the winch cable hook is fully seated when the load is attached.
- Never operate your winch with a damaged hook or latch. Always replace damaged parts before using the winch.

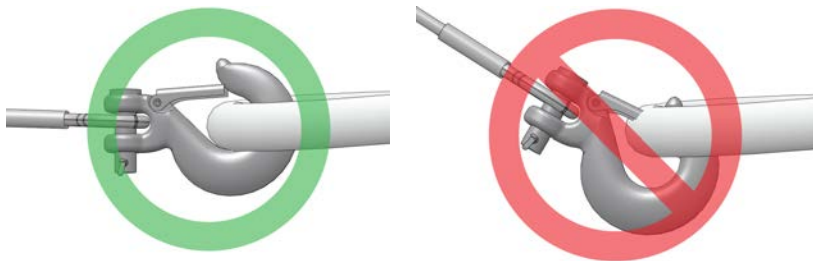

5. Never remove the hook strap from the hook.
6. Release the winch clutch and pull out the winch cable.
7. Pulling out as much cable as possible maximizes the winch's pulling capacity. Always be sure that at least five (5) full turns of winch cable are wrapped around the winch drum at all times. The friction provided by this wrapped cable allows the drum to pull on the winch cable and move the load.

8. Read and adhere to the following information for winch damping to ensure safe winch use.
    - a. In order to absorb energy that could be released by a winch cable failure, always place a “damper” on the winch cable. A damper can be heavy jacket, tarp, or other soft, dense object. A damper can absorb much of the energy released if a winch cable breaks when winching. Even a tree limb can help as a damper if no other items are available to you.
    - b. Lay the damper on top of the mid-point of the winch cable length that is spooled out.
    - c. On a long pull, it may be necessary to stop winching so that the damper can be repositioned to the new mid-point of the winch cable. Always release the tension on the winch cable before repositioning the damper.
    - d. Avoid being directly in line with the winch cable whenever possible. Also, never permit others to stand near or in line with the winch cable during winch operation.
  9. Never hook the winch cable back onto itself. This will damage the winch cable and may result in winch cable failure.
  10. Never use straps, chains or other rigging items that are damaged or worn.
  11. The ONLY time a winch-equipped vehicle should be moving when using the winch is when that vehicle itself is stuck. The winch equipped vehicle should NEVER be in motion to “shock” load the winch cable in an attempt to move a second stuck vehicle. See the Shock Loading section on page 110. For your safety, always follow these guidelines when winching a vehicle free:
    - a. Release the winch clutch and spool out the necessary length of winch cable.
    - b. Align the winch cable as close as possible to the winching vehicle’s centerline.
    - c. Attach the winch cable hook to the anchor point or the stuck vehicle’s frame following instructions in this manual.
    - d. Re-engage the clutch on the winch.
    - e. Slowly winch in the slack in the winch cable.
    - f. Select the proper vehicle gear to propel the stuck vehicle in the direction of winching.
    - g. Shift to the lowest gear available on the stuck vehicle.
    - h. Slowly and carefully apply vehicle throttle and winch together to free the vehicle.
    - i. Stop winching as soon as the stuck vehicle is able to propel itself without the help of the winch.
-

## WINCH GUIDE

---

- j. Detach the winch cable hook.
  - k. Rewind the winch cable evenly back onto the winch drum following the instructions in this manual.
12. Never attempt to winch another stuck vehicle by attaching the winch cable to a suspension component, brush guard, bumper or cargo rack. Vehicle damage may result. Instead, attach the winch to a strong portion of the vehicle frame or hitch.
13. Extensive winching will run down the battery on the winching vehicle. Let the winching vehicle's engine run while operating the winch to prevent the battery from running low if winching for long periods.
14. The winch motor may become hot during winch use. If you winch for more than 45 seconds, or if the winch stalls during operation, stop winching and permit the winch to cool down for 10 minutes before using it again.
15. After winching is complete, especially if winching at an angle, it may be necessary to re-distribute the winch cable across the winch drum. You will need an assistant to perform this task.
- a. Release the clutch on the winch.
  - b. Feed out the winch cable that is unevenly bunched up in one area.
  - c. Re-engage the winch clutch.
  - d. Have an assistant pull the winch cable tightly with about 100 lbs. (45 kg) of tension using the hook strap.
  - e. Slowly winch the cable in while your assistant moves the end of the winch cable back and forth horizontally to evenly distribute the winch cable on the drum.
  - f. Doing this reduces the chances of the winch cable "wedging" itself between lower layers of winch cable.

## WINCH CABLE CARE

### WARNING

Use of worn or damaged cable could lead to sudden failure and SEVERE INJURY.

For your safety, always replace POLARIS winch parts (including the cable) with genuine POLARIS replacement parts available at your authorized POLARIS dealer, or other qualified person.

1. Always inspect your winch before each use. Inspect for worn or loose parts including mounting hardware. Never use the winch if any part needs repair or replacement.
2. Always inspect your winch cable before each use. Inspect for worn or kinked winch cable.

A kinked winch cable made of wire rope is shown at right. Even after being “straightened out,” this cable has already been permanently and severely damaged. Promptly discontinue use of a winch cable in this condition.

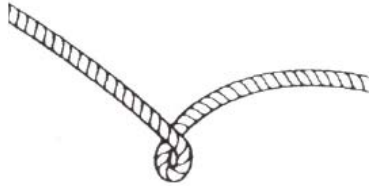

A kinked winch cable made of wire rope that has been “straightened out” is shown at right. Even though it may look usable, the cable has been permanently and severely damaged. It can no longer transmit the load that it could prior to kinking. Promptly discontinue use of a winch cable in this condition.

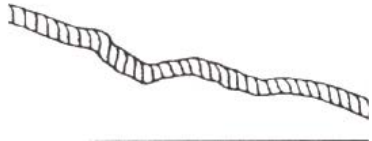

A winch cable made of synthetic rope should be inspected for signs of fraying. Replace the cable if fraying is observed (shown below). Promptly discontinue use of a winch cable in this condition. Also replace the winch cable if there are fused or melted fibers. Such an area of the synthetic rope will be stiff and appear smooth or glazed. Promptly discontinue use of a winch cable in this condition.

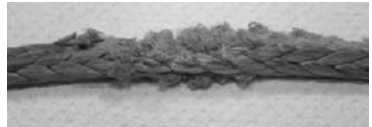

### SHOCK LOADING

 WARNING

Your winch cable is very strong but it is NOT designed for dynamic, or “shock” loading. Shock loading may tension a winch cable beyond its strength and cause the cable to break. The end of a broken winch cable under such high loading can cause SEVERE INJURY or DEATH to you and other bystanders.

*Winch cables are designed to NOT absorb energy. This is true of both wire-ropes and synthetic-rope winch cables.*

1. Never attempt to “jerk” a load with the winch. For example, never take up slack in the winch cable by moving the winching vehicle in an attempt to move an object. This is a dangerous practice. It generates high winch cable loads that may exceed the strength of the cable. Even a slowly moving vehicle can create large shock loads in a winch cable.

 WARNING

SEVERE INJURY or DEATH can result from a broken winch cable.

2. Never quickly turn the winch ON and OFF repeatedly (“jogging”). This puts extra load on the winch, winch cable, and generates excessive heat from the motor. This is a form of shock loading.
3. Never tow a vehicle or other object with your winch. Towing an object with a winch produces shock loading of the cable even when towing at slow speeds. Towing from a winch also positions the towing force high on the vehicle. This can cause instability of the vehicle and possibly lead to an accident.
4. Never use recovery straps with your winch. Recovery straps are designed to stretch and can store energy. This stored energy in the recovery strap is released if a winch cable fails making the event even more hazardous. Similarly, never use elastic “bungee” cords for winching.
5. Never use the winch to tie down a vehicle to a trailer or other transportation vehicle. This type of use also causes shock loading that can cause damage to the winch, winch cable, or vehicles used.

**Your winch cable is designed and tested to withstand the loads produced by the winch motor when operated from a stationary vehicle. Always remember that the winch and winch cable are NOT designed for shock loading.**



---

## WINCH MAINTENANCE AND SERVICE SAFETY

 **WARNING**

Improper or lack of winch maintenance and service could lead to **SEVERE INJURY** or **DEATH**. Always follow all winch instructions and warnings in this manual.

1. Always inspect your winch before each use. Inspect for worn or kinked winch cable. Also inspect for worn or loose parts including mounting hardware.
2. Permit your winch motor to cool down prior to servicing your winch.
3. Never work on your winch without first disconnecting the battery connections to prevent accidental activation of the winch.
4. For your safety, always replace POLARIS winch parts (including the cable) with genuine POLARIS replacement parts available at your authorized POLARIS dealer, or other qualified person.
5. Some winch models use wire rope as the winch cable. Other winches use a specially designed synthetic rope as the winch cable.
6. Never replace a synthetic-rope winch cable with a consumer-grade polymer rope such as can be purchased in a hardware store. Although they may look similar, they are **NOT** alike. A polymer rope not designed for winch use will stretch and store excessive energy when winching.

 **WARNING**

Failure of a stretched rope under winching conditions will release all of the stored energy. This will increase the chances of **SEVERE INJURY** or **DEATH**.



# EMISSION CONTROL SYSTEMS

## NOISE EMISSION CONTROL SYSTEM

Do not modify the engine, intake or exhaust components, as doing so may affect compliance with U.S.A. EPA noise control requirements (40 CFR 205) and local noise level requirements.

## OPERATION ON PUBLIC LANDS IN THE U.S.A.

Your POLARIS vehicle has a spark arrester that was tested and qualified to be in accordance with the USFS standard 5100-1C. Federal law requires that this spark arrester be installed and functional when the vehicle is operated on public lands.

Operation of off-road vehicles on public lands in the U.S.A. is regulated by 43 CFR 420. Violations are subject to monetary penalties. Federal regulations can be viewed online at [www.gpoaccess.gov/ecfr/](http://www.gpoaccess.gov/ecfr/).

## CRANKCASE EMISSION CONTROL SYSTEM

This engine is equipped with a closed crankcase system. Blow-by gases are forced back to the combustion chamber by the intake system. All exhaust gases exit through the exhaust system.

## EXHAUST EMISSION CONTROL SYSTEM

Exhaust emissions are controlled by engine design. An electronic fuel injection (EFI) system controls fuel delivery. The engine and EFI components are set at the factory for optimal performance and are not adjustable.

The emissions label is located on the left front frame of the vehicle.

## ELECTROMAGNETIC INTERFERENCE

This spark ignition system complies with Canadian ICES-002.

This vehicle complies with the EMC requirements of European directives 97/24/EC and 2004/108/EC.

**Non-ionizing Radiation:** This vehicle emits some electromagnetic energy. People with active or non-active implantable medical devices (such as heart monitoring or controlling devices) should review the limitations of their device and the applicable electromagnetic standards and directives that apply to this vehicle.



---

# MAINTENANCE

## PERIODIC MAINTENANCE CHART

 **WARNING**

If servicing the vehicle involves removing/adjusting vehicle components, be absolutely sure to reinstall as before. Components that are missing or improperly installed may not adequately deflect heat from hot vehicle components, which could result in serious injury or death.

Any qualified repair shop or person may maintain, replace or repair the emission control devices or systems on your vehicle. An authorized POLARIS dealer can perform any service that may be necessary for your vehicle. POLARIS also recommends POLARIS parts for emissions-related service, however equivalent parts can be used.

It is a potential violation of the Clean Air Act if a part supplied by an aftermarket parts manufacturer reduces the effectiveness of the vehicle's emission controls. Tampering with emission controls is prohibited by federal law.

Owners are responsible for performing the scheduled maintenance identified in this owner's manual.

Careful periodic maintenance will help keep your vehicle in the safest, most reliable condition. Inspection, adjustment and lubrication of important components are explained in the periodic maintenance chart.

Inspect, clean, lubricate, adjust and replace parts as necessary. When inspection reveals the need for replacement parts, genuine POLARIS parts are available from your POLARIS dealer. Equivalent parts may be used for emissions-related service.

Service and adjustments are important for proper vehicle operation. If you're not familiar with safe service and adjustment procedures, a qualified dealer can perform these operations.

Vehicles subjected to heavy or severe use patterns must be inspected and serviced more frequently.

### SEVERE USE DEFINITION

- Frequent immersion in mud, water or sand
- Racing or race-style high RPM use
- Prolonged low speed, heavy load operation
- Extended idle
- Frequent short trip operation in cold weather (engine frequently does not operate long enough to reach full operating temperature)

## MAINTENANCE

---

Pay special attention to the oil level. A rise in oil level during cold weather can indicate contaminants collecting in the oil sump or crankcase. Change oil immediately if the oil level begins to rise. Monitor the oil level, and if it continues to rise, discontinue use and determine the cause. Your POLARIS dealer or other authorized person can assist.

### MAINTENANCE CHART TABLES

The maintenance interval charts outline required maintenance and inspection based on vehicle hours / miles. Each table states the number of hours / miles that service is required on the vehicle. Some items or components may need to be serviced more often due to severe use, such as operation in water or under severe loads. When the vehicle goes beyond 500 hours / 5000 miles, return to the 25 hours / 250 mile chart and start the interval process over.

#### **25 HOUR / 250 MILE (400 KM) SERVICE**

COMPONENT		REMARKS
XU /D	Brake Pads / Parking Brake Pads (INT'L)	Inspect pad wear
	Fuel System	Turn key on to pressurize fuel pump; check lines / fittings for leaks and abrasion
XU /D	Parking Brake Cable Adjustment (INT'L)	Inspect; adjust tension after first 25 hours
XU	Engine Breather	Inspect; clean
	Battery	Check terminals; clean; test
XU	Engine Oil & Filter Change (Break-In)	Perform a break-in oil and filter change at 25 hours or one month; perform every 50 hours or 6 months thereafter
XU	Front Gearcase Lubricant	Initial fluid level inspection; add lubricant if needed
XU	Transmission Lubricant (AGL)	Initial fluid level inspection; add lubricant if needed
	Spark Arrestor	Clean daily if driven in mud / water; replace a damaged arrestor before operating. Otherwise, clean at 2000 mile (3200 km) mark.

XU - Perform these procedures more often for vehicles subjected to severe use.

D - Have an authorized Polaris dealer or other qualified person perform these services.

**50 HOUR / 500 MILE (800 KM) SERVICE**

ITEM		REMARKS
XU / D	Brake Pads / Parking Brake Pads (INT'L)	Inspect pad wear
	Fuel System	Turn key on to pressurize fuel pump; check lines / fittings for leaks and abrasion
XU / D	Parking Brake Cable Adjustment (INT'L)	Inspect; adjust tension after first 25 hours
XU	Engine Breather	Inspect; clean
	Battery	Check terminals; clean; test
XU	Front Gearcase Lubricant	Inspect / add lubricant if needed
XU	Transmission Lubricant (AGL)	Inspect / add lubricant if needed
XU	General Lubrication	Lubricate all fittings, pivots, cables, etc.
D	Throttle Pedal	Inspect; replace if it sticks
	Throttle Body Intake Ducts/Flange	Inspect ducts for proper sealing / air leaks
	Shift Cable / Linkage	Inspect; adjust as needed
D	Steering	Lubricate (if applicable)
XU	Front / Rear Suspension	Lubricate (if applicable)
D	Cooling System	Inspect coolant strength seasonally; pressure test system yearly
D	Drive Belt	Inspect; replace as needed
XU / D	Clutches (Drive and Driven)	Inspect; clean; replace worn parts
XU	Engine Oil Lines/ Fasteners	Inspect for leaks and loose fittings
D	Charge Air Cooler	Inspect; clean external surfaces
XU	Radiator(s)	Inspect; clean external surfaces
XU	Cooling hoses	Inspect; clean external surfaces
XU	Shock Absorbers	Inspect for leaks, loose joints, and wear

XU - Perform these procedures more often for vehicles subjected to severe use.

D - Have an authorized Polaris dealer or other qualified person perform these services.

## MAINTENANCE

---

### **75 HOUR / 750 MILE (1200 KM) SERVICE**

COMPONENT		REMARKS
XU /D	Brake Pads / Parking Brake Pads (INT'L)	Inspect pad wear
	Fuel System	Turn key on to pressurize fuel pump; check lines / fittings for leaks and abrasion
XU /D	Parking Brake Cable Adjustment (INT'L)	Inspect; adjust tension after first 25 hours
XU	Engine Breather	Inspect; clean
	Battery	Check terminals; clean; test
XU	Engine Oil & Filter Change	Change oil and filter, inspect used oil for contaminants
XU	Front Gearcase Lubricant	Inspect / add lubricant if needed
XU	Transmission Lubricant (AGL)	Inspect / add lubricant if needed

XU - Perform these procedures more often for vehicles subjected to severe use.

D - Have an authorized Polaris dealer or other qualified person perform these services.



**100 HOUR / 1000 MILE (1600 KM) SERVICE**

ITEM		REMARKS
XU / D	Brake Pads / Parking Brake Pads (INT'L)	Inspect pad wear
	Fuel System	Turn key on to pressurize fuel pump; check lines / fittings for leaks and abrasion
XU / D	Parking Brake Cable Adjustment (INT'L)	Inspect; adjust tension after first 25 hours
XU	Engine Breather	Inspect; clean
	Battery	Check terminals; clean; test
XU	General Lubrication	Lubricate all fittings, pivots, cables, etc.
D	Throttle Pedal	Inspect; replace if it sticks
	Throttle Body Intake Ducts/Flange	Inspect ducts for proper sealing / air leaks
	Shift Cable / Linkage	Inspect; adjust as needed
D	Steering	Lubricate (if applicable)
XU	Front / Rear Suspension	Lubricate (if applicable)
D	Cooling System	Inspect coolant strength seasonally; pressure test system yearly
D	Drive Belt	Inspect; replace as needed
XU	Engine Oil Lines/ Fasteners	Inspect for leaks and loose fittings
XU / D	Parking Brake Cable Adjustment (INT'L)	Inspect; adjust tension as needed
XU	Front Gearcase Lubricant	Change lubricant
XU	Transmission Lubricant (AGL)	Change lubricant
D	Fuel System	Check for leaks at fill cap, fuel line / rail, and fuel pump.
D	Spark Plug Inspection	Inspect; replace as needed; torque to specification
XU	Radiator	Inspect; clean external surfaces
XU	Cooling Hoses	Inspect for leaks; pressure test system
XU	Engine Mounts	Inspect, torque to specification
	Exhaust Silencer / Pipe	Inspect

## MAINTENANCE

XU /D	BRAKE PADS / PARKING BRAKE PADS (INT'L)	INSPECT PAD WEAR
XU	Wiring	Inspect for wear, routing, security; inspect connectors subjected to water, mud, etc.
XU /D	Clutches (Drive and Driven)	Inspect; clean; replace worn parts
D	Wheel Bearings	Inspect; replace as needed
	Cam Chain Tensioner	Inspect/clean; replace as needed

XU - Perform these procedures more often for vehicles subjected to severe use.

D - Have an authorized Polaris dealer or other qualified person perform these services.

**125 HOUR / 1250 MILE (2000 KM) SERVICE**

COMPONENT		REMARKS
XU / D	Brake Pads / Parking Brake Pads (INT'L)	Inspect pad wear
	Fuel System	Turn key on to pressurize fuel pump; check lines / fittings for leaks and abrasion
XU / D	Parking Brake Cable Adjustment (INT'L)	Inspect; adjust tension after first 25 hours
XU	Engine Breather	Inspect; clean
	Battery	Check terminals; clean; test
XU	Engine Oil & Filter Change	Change oil and filter, inspect used oil for contaminants
XU	Front Gearcase Lubricant	Inspect / add lubricant if needed
XU	Transmission Lubricant (AGL)	Inspect / add lubricant if needed

XU - Perform these procedures more often for vehicles subjected to severe use.

D - Have an authorized Polaris dealer or other qualified person perform these services.

## MAINTENANCE

### **150 HOUR / 1500 MILE (2400 KM) SERVICE**

ITEM		REMARKS
XU / D	Brake Pads / Parking Brake Pads (INT'L)	Inspect pad wear
	Fuel System	Turn key on to pressurize fuel pump; check lines / fittings for leaks and abrasion
XU / D	Parking Brake Cable Adjustment (INT'L)	Inspect; adjust tension after first 25 hours
XU	Engine Breather	Inspect; clean
	Battery	Check terminals; clean; test
XU	Front Gearcase Lubricant	Inspect / add lubricant if needed
XU	Transmission Lubricant (AGL)	Inspect / add lubricant if needed
XU	General Lubrication	Lubricate all fittings, pivots, cables, etc.
D	Throttle Pedal	Inspect; replace if it sticks
	Throttle Body Intake Ducts/Flange	Inspect ducts for proper sealing / air leaks
	Shift Cable / Linkage	Inspect; adjust as needed
D	Steering	Lubricate (if applicable)
XU	Front / Rear Suspension	Lubricate (if applicable)
D	Cooling System	Inspect coolant strength seasonally; pressure test system yearly
D	Drive Belt	Inspect; replace as needed
XU / D	Clutches (Drive and Driven)	Inspect; clean; replace worn parts
XU	Engine Oil Lines/ Fasteners	Inspect for leaks and loose fittings

XU - Perform these procedures more often for vehicles subjected to severe use.

D - Have an authorized Polaris dealer or other qualified person perform these services.

**175 HOUR / 1750 MILE (2800 KM) SERVICE**

COMPONENT		REMARKS
XU / D	Brake Pads / Parking Brake Pads (INT'L)	Inspect pad wear
	Fuel System	Turn key on to pressurize fuel pump; check lines / fittings for leaks and abrasion
XU / D	Parking Brake Cable Adjustment (INT'L)	Inspect; adjust tension after first 25 hours
XU	Engine Breather	Inspect; clean
	Battery	Check terminals; clean; test
XU	Engine Oil & Filter Change	Change oil and filter, inspect used oil for contaminants
XU	Front Gearcase Lubricant	Inspect / add lubricant if needed
XU	Transmission Lubricant (AGL)	Inspect / add lubricant if needed

XU - Perform these procedures more often for vehicles subjected to severe use.

D - Have an authorized Polaris dealer or other qualified person perform these services.

## MAINTENANCE

### **200 HOUR / 2000 MILE (3200 KM) SERVICE**

ITEM		REMARKS
XU / D	Brake Pads / Parking Brake Pads (INT'L)	Inspect pad wear
	Fuel System	Turn key on to pressurize fuel pump; check lines / fittings for leaks and abrasion
XU / D	Parking Brake Cable Adjustment (INT'L)	Inspect; adjust tension after first 25 hours
XU	Engine Breather	Inspect; clean
	Battery	Check terminals; clean; test
XU	General Lubrication	Lubricate all fittings, pivots, cables, etc.
D	Throttle Pedal	Inspect; replace if it sticks
	Throttle Body Intake Ducts/Flange	Inspect ducts for proper sealing / air leaks
	Shift Cable / Linkage	Inspect; adjust as needed
D	Steering	Lubricate (if applicable)
XU	Front / Rear Suspension	Lubricate (if applicable)
D	Cooling System	Inspect coolant strength seasonally; pressure test system yearly
D	Drive Belt	Inspect; replace as needed
XU / D	Clutches (Drive and Driven)	Inspect; clean; replace worn parts
XU	Engine Oil Lines/ Fasteners	Inspect for leaks and loose fittings
XU / D	Parking Brake Cable Adjustment (INT'L)	Inspect; adjust tension as needed
XU	Front Gearcase Lubricant	Change lubricant
XU	Transmission Lubricant (AGL)	Change lubricant
D	Fuel System	Check for leaks at fill cap, fuel line / rail, and fuel pump.
D	Spark Plug Inspection	Inspect; replace as needed; torque to specification
XU	Radiator	Inspect; clean external surfaces
XU	Cooling Hoses	Inspect for leaks; pressure test system
XU	Engine Mounts	Inspect, torque to specification

## MAINTENANCE

XU / D	BRAKE PADS / PARKING BRAKE PADS (INT'L)	INSPECT PAD WEAR
	Exhaust Silencer / Pipe	Inspect
XU	Wiring	Inspect routing and for wear; inspect connectors subjected to water/mud.
D	Wheel Bearings	Inspect; replace as needed
D	Brake Fluid	Change every two years (DOT 4)
	Spark Arrestor	Clean daily if driven in mud / water; replace a damaged arrestor before operating
	Cam Chain Tensioner	Inspect/clean; replace as needed
D	Valve Clearance	Inspect; adjust as needed

XU - Perform these procedures more often for vehicles subjected to severe use.

D - Have an authorized Polaris dealer or other qualified person perform these services.

## MAINTENANCE

---

### **225 HOUR / 2250 MILE (3600 KM) SERVICE**

COMPONENT		REMARKS
XU / D	Brake Pads / Parking Brake Pads (INT'L)	Inspect pad wear
	Fuel System	Turn key on to pressurize fuel pump; check lines / fittings for leaks and abrasion
XU / D	Parking Brake Cable Adjustment (INT'L)	Inspect; adjust tension after first 25 hours
XU	Engine Breather	Inspect; clean
	Battery	Check terminals; clean; test
XU	Engine Oil & Filter Change	Change oil and filter, inspect used oil for contaminants
XU	Front Gearcase Lubricant	Inspect / add lubricant if needed
XU	Transmission Lubricant (AGL)	Inspect / add lubricant if needed

XU - Perform these procedures more often for vehicles subjected to severe use.

D - Have an authorized Polaris dealer or other qualified person perform these services.



**250 HOUR / 2500 MILE (4000 KM) SERVICE**

ITEM		REMARKS
XU / D	Brake Pads / Parking Brake Pads (INT'L)	Inspect pad wear
	Fuel System	Turn key on to pressurize fuel pump; check lines / fittings for leaks and abrasion
XU / D	Parking Brake Cable Adjustment (INT'L)	Inspect; adjust tension after first 25 hours
XU	Engine Breather	Inspect; clean
	Battery	Check terminals; clean; test
XU	Front Gearcase Lubricant	Inspect / add lubricant if needed
XU	Transmission Lubricant (AGL)	Inspect / add lubricant if needed
XU	General Lubrication	Lubricate all fittings, pivots, cables, etc.
D	Throttle Pedal	Inspect; replace if it sticks
	Throttle Body Intake Ducts/Flange	Inspect ducts for proper sealing / air leaks
	Shift Cable / Linkage	Inspect; adjust as needed
D	Steering	Lubricate (if applicable)
XU	Front / Rear Suspension	Lubricate (if applicable)
D	Cooling System	Inspect coolant strength seasonally; pressure test system yearly
D	Drive Belt	Inspect; replace as needed
XU / D	Clutches (Drive and Driven)	Inspect; clean; replace worn parts
XU	Engine Oil Lines/ Fasteners	Inspect for leaks and loose fittings
XU / D	Shock Absorbers	Replace or rebuild (if applicable)

XU - Perform these procedures more often for vehicles subjected to severe use.

D - Have an authorized Polaris dealer or other qualified person perform these services.

## MAINTENANCE

---

### **275 HOUR / 2750 MILE (4400 KM) SERVICE**

COMPONENT		REMARKS
XU /D	Brake Pads / Parking Brake Pads (INT'L)	Inspect pad wear
	Fuel System	Turn key on to pressurize fuel pump; check lines / fittings for leaks and abrasion
XU /D	Parking Brake Cable Adjustment (INT'L)	Inspect; adjust tension after first 25 hours
XU	Engine Breather	Inspect; clean
	Battery	Check terminals; clean; test
XU	Engine Oil & Filter Change	Change oil and filter, inspect used oil for contaminants
XU	Front Gearcase Lubricant	Inspect / add lubricant if needed
XU	Transmission Lubricant (AGL)	Inspect / add lubricant if needed

XU - Perform these procedures more often for vehicles subjected to severe use.

D - Have an authorized Polaris dealer or other qualified person perform these services.

**300 HOUR / 3000 MILE (4800 KM) SERVICE**

ITEM		REMARKS
XU / D	Brake Pads / Parking Brake Pads (INT'L)	Inspect pad wear
	Fuel System	Turn key on to pressurize fuel pump; check lines / fittings for leaks and abrasion
XU / D	Parking Brake Cable Adjustment (INT'L)	Inspect; adjust tension after first 25 hours
XU	Engine Breather	Inspect; clean
	Battery	Check terminals; clean; test
XU	General Lubrication	Lubricate all fittings, pivots, cables, etc.
D	Throttle Pedal	Inspect; replace if it sticks
	Throttle Body Intake Ducts/Flange	Inspect ducts for proper sealing / air leaks
	Shift Cable / Linkage	Inspect; adjust as needed
D	Steering	Lubricate (if applicable)
XU	Front / Rear Suspension	Lubricate (if applicable)
D	Cooling System	Inspect coolant strength seasonally; pressure test system yearly
D	Drive Belt	Inspect; replace as needed
XU / D	Clutches (Drive and Driven)	Inspect; clean; replace worn parts
XU	Engine Oil Lines/ Fasteners	Inspect for leaks and loose fittings
XU / D	Parking Brake Cable Adjustment (INT'L)	Inspect; adjust tension as needed
XU	Front Gearcase Lubricant	Change lubricant
XU	Transmission Lubricant (AGL)	Change lubricant
D	Fuel System	Check for leaks at fill cap, fuel line / rail, and fuel pump.
D	Spark Plug Inspection	Inspect; replace as needed; torque to specification
XU	Radiator	Inspect; clean external surfaces
XU	Cooling Hoses	Inspect for leaks; pressure test system
XU	Engine Mounts	Inspect, torque to specification

## MAINTENANCE

XU /D	BRAKE PADS / PARKING BRAKE PADS (INT'L)	INSPECT PAD WEAR
	Exhaust Silencer / Pipe	Inspect
XU	Wiring	Inspect for wear, routing, security; inspect connectors subjected to water, mud, etc.
D	Wheel Bearings	Inspect; replace as needed
	Cam Chain Tensioner	Inspect/clean; replace as needed

XU - Perform these procedures more often for vehicles subjected to severe use.

D - Have an authorized Polaris dealer or other qualified person perform these services.

**325 HOUR / 3250 MILE (5200 KM) SERVICE**

COMPONENT		REMARKS
XU / D	Brake Pads / Parking Brake Pads (INT'L)	Inspect pad wear
	Fuel System	Turn key on to pressurize fuel pump; check lines / fittings for leaks and abrasion
XU / D	Parking Brake Cable Adjustment (INT'L)	Inspect; adjust tension after first 25 hours
XU	Engine Breather	Inspect; clean
	Battery	Check terminals; clean; test
XU	Engine Oil & Filter Change	Change oil and filter, inspect used oil for contaminants
XU	Front Gearcase Lubricant	Inspect / add lubricant if needed
XU	Transmission Lubricant (AGL)	Inspect / add lubricant if needed

XU - Perform these procedures more often for vehicles subjected to severe use.

D - Have an authorized Polaris dealer or other qualified person perform these services.

## MAINTENANCE

### **350 HOUR / 3500 MILE (5600 KM) SERVICE**

ITEM		REMARKS
XU /D	Brake Pads / Parking Brake Pads (INT'L)	Inspect pad wear
	Fuel System	Turn key on to pressurize fuel pump; check lines / fittings for leaks and abrasion
XU /D	Parking Brake Cable Adjustment (INT'L)	Inspect; adjust tension after first 25 hours
XU	Engine Breather	Inspect; clean
	Battery	Check terminals; clean; test
XU	Front Gearcase Lubricant	Inspect / add lubricant if needed
XU	Transmission Lubricant (AGL)	Inspect / add lubricant if needed
XU	General Lubrication	Lubricate all fittings, pivots, cables, etc.
D	Throttle Pedal	Inspect; replace if it sticks
	Throttle Body Intake Ducts/Flange	Inspect ducts for proper sealing / air leaks
	Shift Cable / Linkage	Inspect; adjust as needed
D	Steering	Lubricate (if applicable)
XU	Front / Rear Suspension	Lubricate (if applicable)
D	Cooling System	Inspect coolant strength seasonally; pressure test system yearly
D	Drive Belt	Inspect; replace as needed
XU /D	Clutches (Drive and Driven)	Inspect; clean; replace worn parts
XU	Engine Oil Lines/ Fasteners	Inspect for leaks and loose fittings

XU - Perform these procedures more often for vehicles subjected to severe use.

D - Have an authorized Polaris dealer or other qualified person perform these services.

**375 HOUR / 3750 MILE (6000 KM) SERVICE**

COMPONENT		REMARKS
XU / D	Brake Pads / Parking Brake Pads (INT'L)	Inspect pad wear
	Fuel System	Turn key on to pressurize fuel pump; check lines / fittings for leaks and abrasion
XU / D	Parking Brake Cable Adjustment (INT'L)	Inspect; adjust tension after first 25 hours
XU	Engine Breather	Inspect; clean
	Battery	Check terminals; clean; test
XU	Engine Oil & Filter Change	Change oil and filter, inspect used oil for contaminants
XU	Front Gearcase Lubricant	Inspect / add lubricant if needed
XU	Transmission Lubricant (AGL)	Inspect / add lubricant if needed

XU - Perform these procedures more often for vehicles subjected to severe use.

D - Have an authorized Polaris dealer or other qualified person perform these services.

## MAINTENANCE

### **400 HOUR / 4000 MILE (6400 KM) SERVICE**

ITEM		REMARKS
XU /D	Brake Pads / Parking Brake Pads (INT'L)	Inspect pad wear
	Fuel System	Turn key on to pressurize fuel pump; check lines / fittings for leaks and abrasion
XU /D	Parking Brake Cable Adjustment (INT'L)	Inspect; adjust tension after first 25 hours
XU	Engine Breather	Inspect; clean
	Battery	Check terminals; clean; test
XU	General Lubrication	Lubricate all fittings, pivots, cables, etc.
D	Throttle Pedal	Inspect; replace if it sticks
	Throttle Body Intake Ducts/Flange	Inspect ducts for proper sealing / air leaks
	Shift Cable / Linkage	Inspect; adjust as needed
D	Steering	Lubricate (if applicable)
XU	Front / Rear Suspension	Lubricate (if applicable)
D	Cooling System	Inspect coolant strength seasonally; pressure test system yearly
D	Drive Belt	Inspect; replace as needed
XU /D	Clutches (Drive and Driven)	Inspect; clean; replace worn parts
XU	Engine Oil Lines/ Fasteners	Inspect for leaks and loose fittings
XU /D	Parking Brake Cable Adjustment (INT'L)	Inspect; adjust tension as needed
XU	Front Gearcase Lubricant	Change lubricant
XU	Transmission Lubricant (AGL)	Change lubricant
D	Fuel System	Check for leaks at fill cap, fuel line / rail, and fuel pump.
D	Spark Plug Inspection	Inspect; replace as needed; torque to specification
XU	Radiator	Inspect; clean external surfaces
XU	Cooling Hoses	Inspect for leaks; pressure test system
XU	Engine Mounts	Inspect, torque to specification



## MAINTENANCE

XU /D	BRAKE PADS / PARKING BRAKE PADS (INT'L)	INSPECT PAD WEAR
	Exhaust Silencer / Pipe	Inspect
XU	Wiring	Inspect for wear, routing, security; inspect connectors subjected to water, mud, etc.
D	Wheel Bearings	Inspect; replace as needed
D	Brake Fluid	Change every two years (DOT 4)
	Spark Arrestor	Clean daily if driven in mud / water; replace a damaged arrestor before operating
	Cam Chain Tensioner	Inspect/clean; replace as needed
D / E	Valve Clearance	Inspect; adjust as needed

XU - Perform these procedures more often for vehicles subjected to severe use.

D - Have an authorized Polaris dealer or other qualified person perform these services.

## MAINTENANCE

---

### **425 HOUR / 4250 MILE (6800 KM) SERVICE**

COMPONENT		REMARKS
XU /D	Brake Pads / Parking Brake Pads (INT'L)	Inspect pad wear
	Fuel System	Turn key on to pressurize fuel pump; check lines / fittings for leaks and abrasion
XU /D	Parking Brake Cable Adjustment (INT'L)	Inspect; adjust tension after first 25 hours
XU	Engine Breather	Inspect; clean
	Battery	Check terminals; clean; test
XU	Engine Oil & Filter Change	Change oil and filter, inspect used oil for contaminants
XU	Front Gearcase Lubricant	Inspect / add lubricant if needed
XU	Transmission Lubricant (AGL)	Inspect / add lubricant if needed

XU - Perform these procedures more often for vehicles subjected to severe use.

D - Have an authorized Polaris dealer or other qualified person perform these services.

**450 HOUR / 4500 MILE (7200 KM) SERVICE**

ITEM		REMARKS
XU / D	Brake Pads / Parking Brake Pads (INT'L)	Inspect pad wear
	Fuel System	Turn key on to pressurize fuel pump; check lines / fittings for leaks and abrasion
XU / D	Parking Brake Cable Adjustment (INT'L)	Inspect; adjust tension after first 25 hours
XU	Engine Breather	Inspect; clean
	Battery	Check terminals; clean; test
XU	Front Gearcase Lubricant	Inspect / add lubricant if needed
XU	Transmission Lubricant (AGL)	Inspect / add lubricant if needed
XU	General Lubrication	Lubricate all fittings, pivots, cables, etc.
D	Throttle Pedal	Inspect; replace if it sticks
	Throttle Body Intake Ducts/Flange	Inspect ducts for proper sealing / air leaks
	Shift Cable / Linkage	Inspect; adjust as needed
D	Steering	Lubricate (if applicable)
XU	Front / Rear Suspension	Lubricate (if applicable)
D	Cooling System	Inspect coolant strength seasonally; pressure test system yearly
D	Drive Belt	Inspect; replace as needed
XU / D	Clutches (Drive and Driven)	Inspect; clean; replace worn parts
XU	Engine Oil Lines/ Fasteners	Inspect for leaks and loose fittings

XU - Perform these procedures more often for vehicles subjected to severe use.

D - Have an authorized Polaris dealer or other qualified person perform these services.

## MAINTENANCE

---

### **475 HOUR / 4750 MILE (7600 KM) SERVICE**

COMPONENT		REMARKS
XU /D	Brake Pads / Parking Brake Pads (INT'L)	Inspect pad wear
	Fuel System	Turn key on to pressurize fuel pump; check lines / fittings for leaks and abrasion
XU /D	Parking Brake Cable Adjustment (INT'L)	Inspect; adjust tension after first 25 hours
XU	Engine Breather	Inspect; clean
	Battery	Check terminals; clean; test
XU	Engine Oil & Filter Change	Change oil and filter, inspect used oil for contaminants
XU	Front Gearcase Lubricant	Inspect / add lubricant if needed
XU	Transmission Lubricant (AGL)	Inspect / add lubricant if needed

XU - Perform these procedures more often for vehicles subjected to severe use.

D - Have an authorized Polaris dealer or other qualified person perform these services.

**500 HOUR / 5000 MILE (8000 KM) SERVICE**

ITEM		REMARKS
XU / D	Brake Pads / Parking Brake Pads (INT'L)	Inspect pad wear
	Fuel System	Turn key on to pressurize fuel pump; check lines / fittings for leaks and abrasion
XU / D	Parking Brake Cable Adjustment (INT'L)	Inspect; adjust tension after first 25 hours
XU	Engine Breather	Inspect; clean
	Battery	Check terminals; clean; test
XU	General Lubrication	Lubricate all fittings, pivots, cables, etc.
D	Throttle Pedal	Inspect; replace if it sticks
	Throttle Body Intake Ducts/Flange	Inspect ducts for proper sealing / air leaks
	Shift Cable / Linkage	Inspect; adjust as needed
D	Steering	Lubricate (if applicable)
XU	Front / Rear Suspension	Lubricate (if applicable)
D	Cooling System	Inspect coolant strength seasonally; pressure test system yearly
D	Drive Belt	Inspect; replace as needed
XU	Engine Oil Lines/ Fasteners	Inspect for leaks and loose fittings
XU / D	Parking Brake Cable Adjustment (INT'L)	Inspect; adjust tension as needed
XU	Front Gearcase Lubricant	Change lubricant
XU	Transmission Lubricant (AGL)	Change lubricant
D	Fuel System	Check for leaks at fill cap, fuel line / rail, and fuel pump.
D	Spark Plug Inspection	Inspect; replace as needed; torque to specification
XU	Radiator	Inspect; clean external surfaces
XU	Cooling Hoses	Inspect for leaks; pressure test system
XU	Engine Mounts	Inspect, torque to specification
	Exhaust Silencer / Pipe	Inspect

## MAINTENANCE

XU / D	BRAKE PADS / PARKING BRAKE PADS (INT'L)	INSPECT PAD WEAR
XU	Wiring	Inspect for wear, routing, security; inspect connectors subjected to water, mud, etc.
XU / D	Clutches (Drive and Driven)	Inspect; clean; replace worn parts
D	Wheel Bearings	Inspect; replace as needed
D	Brake Fluid	Change every two years (DOT 4)
	Spark Arrestor	Clean daily if driven in mud / water; replace a damaged arrestor before operating
	Cam Chain Tensioner	Inspect; replace as needed
D	Valve Clearance	Inspect; adjust as needed
D	Spark Plug Replacement	Replace; torque to specification
XU	Coolant	Replace coolant
D	Toe Adjustment	Inspect periodically; adjust when parts are replaced
	Cam Chain Tensioner	Inspect/clean; replace as needed

XU - Perform these procedures more often for vehicles subjected to severe use.

D - Have an authorized Polaris dealer or other qualified person perform these services.

When the vehicle goes beyond 500 hours / 5000 miles, return to the 25 hours / 250 mile chart and start the interval process over.

## LUBRICATION RECOMMENDATIONS

Check and lubricate all components at the intervals outlined in the Periodic Maintenance Chart section, or more often under severe use, such as wet or dusty conditions. Items not listed in the chart should be lubricated at the general lubrication interval.

ITEM	LUBE	METHOD
Engine Oil	PS-4 5W-50 4-Cycle Oil and PS-4 Extreme Duty 10W-50 4-Cycle Oil	See page 145.
Brake Fluid	DOT 4 Brake Fluid	Maintain level between fill lines. See page 173.
Transmission Oil (Main Gearcase)	AGL Gearcase Lubricant & Transmission Fluid	See page 148.
Front Gearcase Fluid (Demand Drive)	Demand Drive Fluid	See page 150.
Prop Shaft	Spline Grease	Grease the fitting until fresh grease is seen coming from the joint. Wipe away excess to prevent dirt/debris contamination.
Rear Stabilizer Bar Bushings	All Season Grease or grease conforming to NLGI No. 2	Remove engine access panel and grease 2 fittings (one on each side of vehicle).

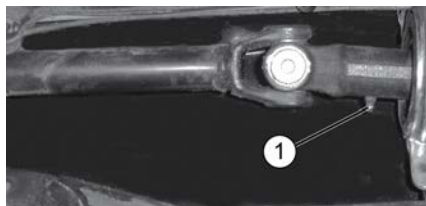

① Middle Prop Shaft Grease Fitting

## MAINTENANCE

---

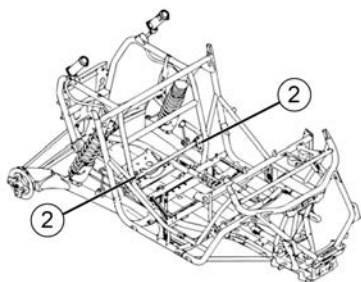

② Rear Stabilizer Bar Bushings (one on each side of vehicle)

③ (Four-Seat Only) Prop Shaft Grease Fittings

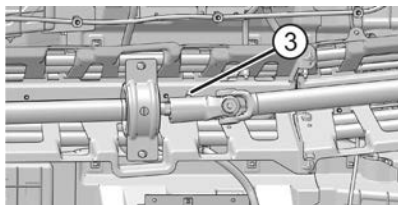
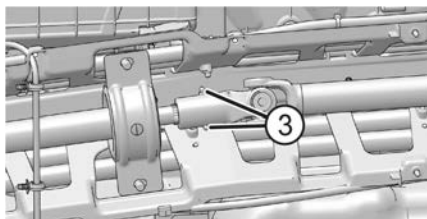



## ENGINE OIL

### OIL RECOMMENDATIONS

 **WARNING**

Vehicle operation with insufficient, deteriorated, or contaminated engine oil will cause accelerated wear and may result in engine seizure, accident, and injury. Always perform the maintenance procedures as outlined in the Periodic Maintenance Chart.

Ambient Temperature Range	Recommended Oil
-35° F to +100° F (-37° C to +38° C)	PS-4 5W-50 4-Cycle Oil
0° F to 120° F (-18° C to +49° C)	PS-4 Extreme Duty 10W-50 4-Cycle Oil

Oil may need to be changed more frequently if POLARIS oil is not used. Do not use automotive oil. Follow the manufacturer's recommendations for ambient temperature operation. Part numbers can be found in the POLARIS Products chapter.

**NOTICE**

Mixing brands or using a non-recommended oil may cause serious engine damage. Always use the recommended oil. Never substitute or mix oil brands.

Always check and change the oil at the intervals outlined in the Periodic Maintenance Chart. Always use the recommended engine oil.

## MAINTENANCE

---

### OIL CHECK

Always check the oil when the engine is cold and on a level surface. If the engine is hot when the oil is checked, the level will appear to be overfull.

Access the oil check dipstick ① through the right rear wheel well. Access the oil fill cap ② by removing the cargo box. See the Service Access Panels section for details.

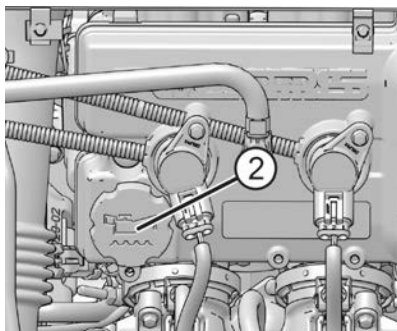
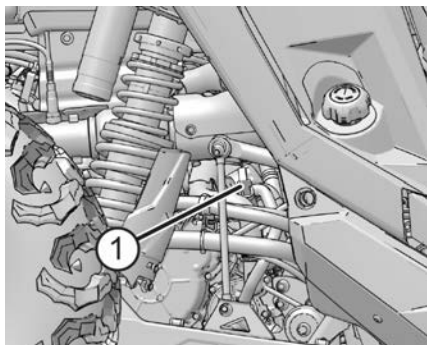

1. Position the vehicle on a level surface.
2. Place the transmission in PARK.
3. Start the engine. Allow the engine to idle for 30 seconds.
4. Stop the engine. Wait two (2) minutes to allow oil to drain back to the sump.
5. Remove the dipstick. Wipe it dry with a clean cloth.
6. Reinstall the dipstick completely. Remove the dipstick and check the oil level.
7. Remove the oil fill cap to add the recommended oil as needed. Maintain the oil level between the minimum and maximum marks on the dipstick. Do not overfill.
8. Reinstall the fill cap. Reinstall the dipstick.

## OIL AND FILTER CHANGE

### WARNING

Spilled oil left on engine components or in the engine area may pose a fire hazard. Use shop rags to clean any spilled oil. If needed, use a non-flammable solvent on the rag to aid the cleaning process. Do not use any device such as pressurized water or air as this may disperse the oil onto engine components and could pose a fire hazard.

Always change the oil and filter at the intervals outlined in the Periodic Maintenance Chart section.

1. Position the vehicle on a level surface. Place the transmission in PARK.
2. Allow engine to cool down before draining oil.
3. Place a drain pan under the engine crankcase and remove the drain plug .

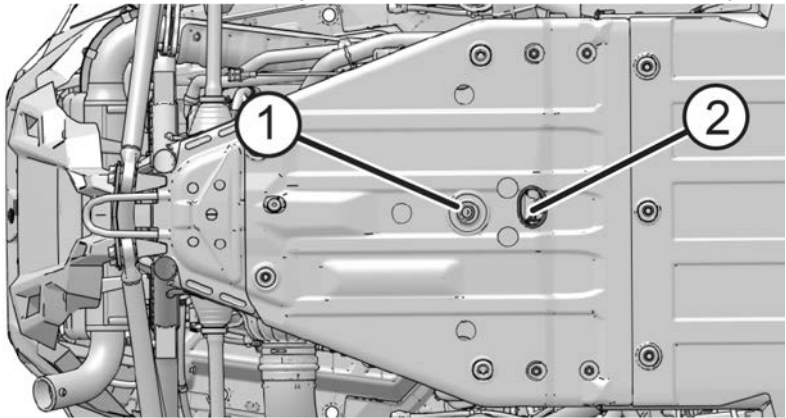

4. Access the oil filter through the access panel behind the seats. See the Service Access Panels section for details.

### NOTE

The engine should be off for at least 2 minutes prior to removing the oil filter.

5. Place drain pan under filter drain  to catch any spilled oil during removal. Using the Oil Filter Wrench, turn the oil filter counterclockwise to remove it. Tip the open end of the oil filter up to minimize oil spill.

## MAINTENANCE

---

6. Clean the filter sealing surface on the engine crankcase with a clean rag and ensure the original oil filter o-ring is not stuck to the crankcase.

### WARNING

Do not use a hose/pressure washer to clean up spilled oil on a vehicle. This may spread oil into surfaces that may get hot which may lead to a fire.

7. Lubricate the o-ring on the new oil filter with a film of clean engine oil. Check to make sure the o-ring is in good condition. Tighten to specification (Turn by hand until filter O-ring contacts sealing surface, then turn an additional 3/4 turn.)
8. Inspect the sealing washer on the drain plug for burrs or nicks. Replace the washer if it is damaged.
9. Reinstall the engine crankcase drain plug. Torque drain plug to specification [12 ft-lbs (16 Nm)].
10. Remove the cargo box. See the Service Access Panels section for details. Add engine oil through the oil fill cap ③ located on top of the engine valve cover.

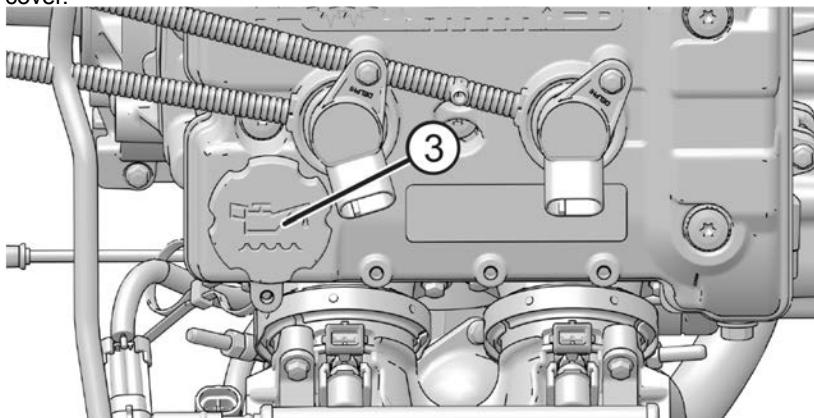

11. Fill the engine to the recommended specification.
12. Start engine and allow it to idle for 30 seconds.
13. Stop the engine and inspect for leaks. Wait at least 15 seconds before removing the oil dipstick.

14. Unlock the dipstick lever ④. Remove the dipstick and wipe it dry with a clean rag.

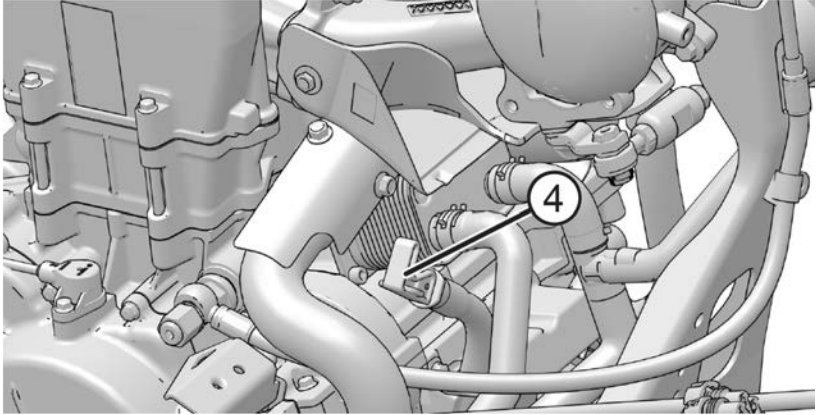

15. Reinstall the dipstick to fully seat it. Do not lock the dipstick.

### NOTE

Make certain the dipstick is inserted all the way down to ensure an accurate reading.

16. Remove the dipstick and check the oil level.

17. Add the recommended oil as necessary to bring the oil level within the SAFE range (between the holes) on the dipstick. Do NOT overfill.

### NOTE

A rising oil level between checks during cold weather operation can indicate contaminants such as gas or moisture collecting in the crankcase. If the oil level is over the upper mark, change the oil immediately.

18. When finished, reinstall dipstick and lock the lever.

19. Reinstall the cargo box.

20. Dispose of used oil, filter, and rags properly.

### TRANSMISSION (MAIN GEARCASE)

Always check and change the fluid at the intervals outlined in the Periodic Maintenance Chart section. Refer to the Gearcase Specifications Chart section for recommended lubricants, capacities and torque specifications.

#### FLUID CHECK

The fill plug ① is located on the rear of the gearcase. Maintain the fluid level at the bottom of the fill plug hole.

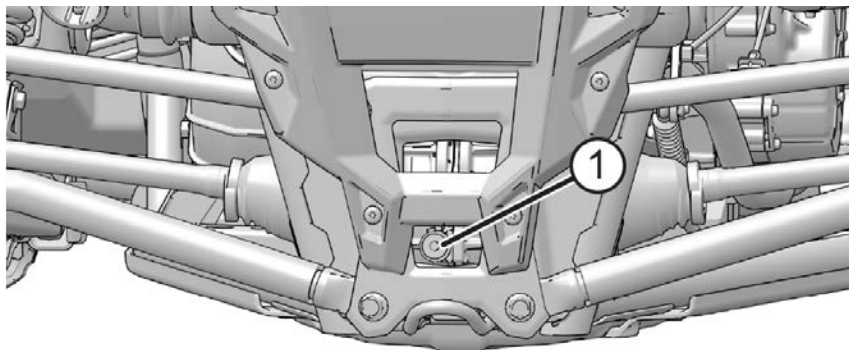

1. Position the vehicle on a level surface.
2. Remove the fill plug.
3. Check the fluid level.
4. Add the recommended fluid to the bottom of the fill plug hole. Do not overfill.
5. Reinstall the fill plug. Torque to specification.

## FLUID CHANGE

The drain plug ① is located on the bottom of the gearcase. Access the drain plug through the drain hole in the skid plate.

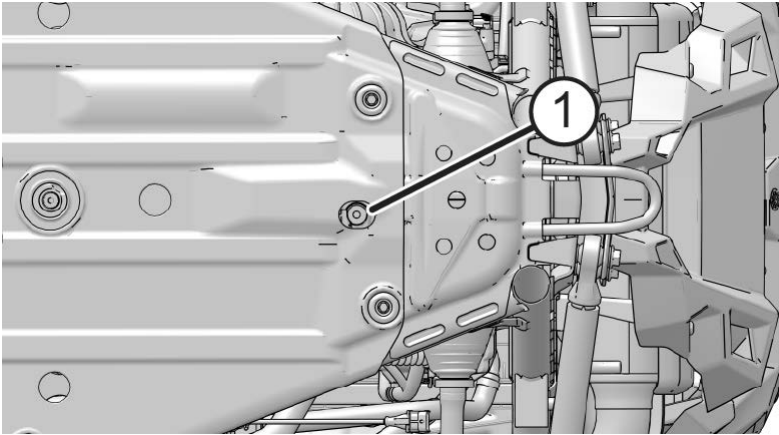

1. Remove the fill plug.
2. Place a drain pan under the drain plug.
3. Remove the drain plug. Allow the fluid to drain completely.
4. Clean the drain plug.
5. Reinstall the drain plug. Torque to specification (listed in the Gearcase Specification Chart of this manual).
6. Add the recommended fluid (listed in the Gearcase Specification Chart) to the bottom of the fill plug hole. Do not overfill.
7. Reinstall the fill plug. Torque to specification (listed in the Gearcase Specification Chart).
8. Check for leaks. Discard used fluid properly.

### DEMAND DRIVE UNIT (FRONT GEARCASE)

Always check and change the fluid at the intervals outlined in the Periodic Maintenance Chart section. Refer to the Gearcase Specifications Chart section for recommended lubricants, capacities and torque specifications.

Fill Plug Location

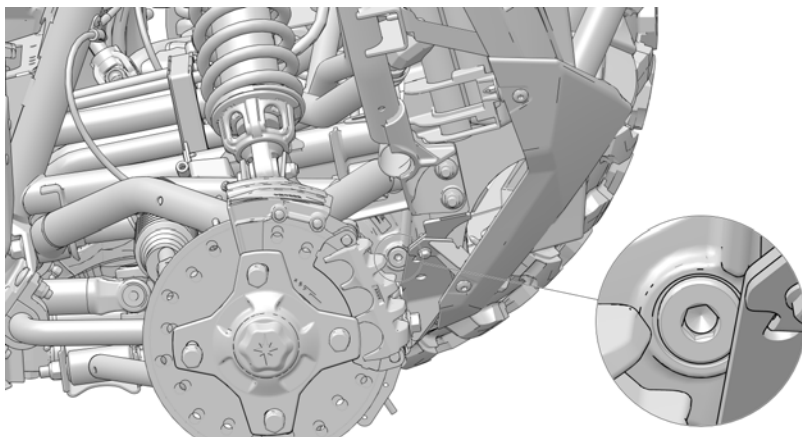

Drain Plug Location

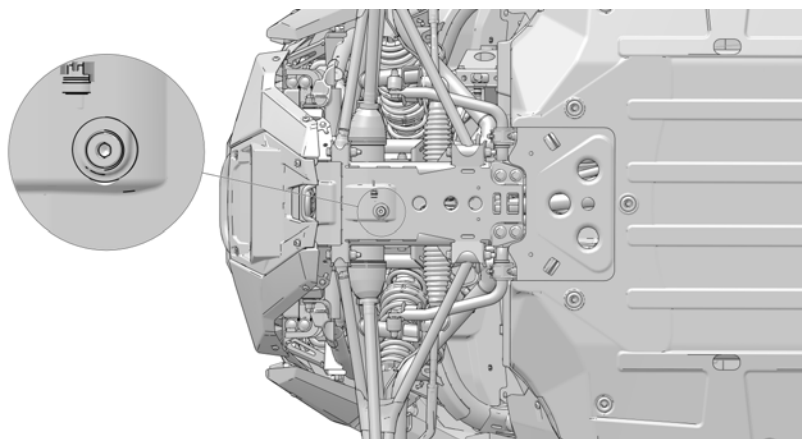



## DEMAND DRIVE FLUID CHECK

The fill plug ① is located on the bottom right side of the demand drive unit. Maintain recommended fluid volume (280 ml).

1. Position the vehicle on a level surface.
2. Remove the fill plug. Check the fluid level.
3. Add the recommended fluid to reach 280 ml capacity.
4. Reinstall the fill plug. Torque to specification.

## DEMAND DRIVE FLUID CHANGE

The demand drive drain plug ② is located on the bottom of the gearcase.

1. Remove the fill plug.
2. Place a drain pan under the drain plug.
3. Remove the drain plug. Allow the fluid to drain completely.
4. Clean the drain plug.
5. Reinstall the drain plug. Torque to specification.
6. Add the recommended fluid (280 ml).
7. Reinstall the fill plug. Torque to specification.
8. Check for leaks. Discard used fluid properly and clean any excess oil residue.

## MAINTENANCE

---

### GEARCASE SPECIFICATION CHART

Use of other fluids may result in improper operation of components. See the Polaris Products section for the part numbers.

<b>Gearcase</b>	<b>Lubricant</b>	<b>Capacity</b>	<b>Fill Plug Torque</b>	<b>Drain Plug Torque</b>
Transmission (Main Gearcase)	AGL Gearcase Lubricant & Transmission Fluid	61 oz. (1800 ml)	10-14 ft. lbs. (14-19 N·m)	10-14 ft. lbs. (14-19 N·m)
Demand Drive Unit (Front Gearcase)	Demand Drive Fluid	9.47 oz. (280 ml)	8-10 ft. lbs. (11-14 N·m)	8-10 ft. lbs. (11-14 N·m)

## SPARK PLUGS

### SPARK PLUG GAP / TORQUE

Electrode Gap	Spark Plug Torque
0.7-0.8 mm	7 ft. lbs. (10 Nm)

#### NOTICE

Using non-recommended spark plugs can result in serious engine damage. Always use POLARIS-recommended spark plugs or their equivalent. Refer to the Specifications section for details.

Spark plug condition is indicative of engine operation. The spark plug firing end condition should be read after the engine is warmed up and the vehicle is driven at higher speeds. Immediately check the spark plug for correct color.

#### CAUTION

A hot exhaust system and engine can cause burns. Wear protective gloves when removing a spark plug for inspection.

## SPARK PLUG REMOVAL AND REPLACEMENT

1. Remove the cargo box to access the spark plugs ①.

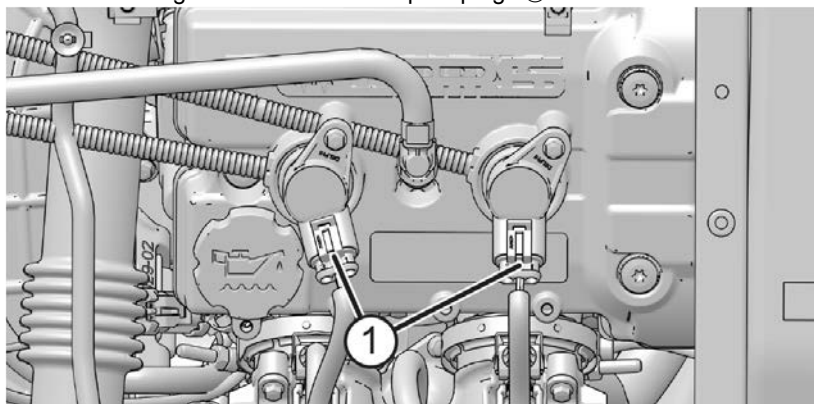

2. Clean the area around the spark plugs before removing the plugs. Unbolt the coils on the plugs.
3. Remove the coil assemblies.

## MAINTENANCE

---

4. Using the spark plug wrench provided in the tool kit, remove the plugs by rotating them counterclockwise.
5. Reverse the procedure for spark plug installation. Torque to specification.

### SPARK PLUG CONDITION

#### ***NORMAL PLUG***

The normal insulator tip is gray, tan or light brown. There will be few combustion deposits. The electrodes are not burned or eroded. This indicates the proper type and heat range for the engine and the service.

#### TIP

The tip should not be white. A white insulator tip indicates overheating, caused by use of an improper spark plug or incorrect throttle body adjustments.

#### ***WET FOULED PLUG***

The wet fouled insulator tip is black. A damp oil film covers the firing end. There may be a carbon layer over the entire nose. Generally, the electrodes are not worn. Fouling may be caused by excessive oil or by frequent short trips, especially in cold weather.

## FUSE / RELAY CENTER

**⚠ WARNING**

Do not arrange fuses improperly or use replacement fuses with improper amperage values. This could lead to electrical overload, which can result in severe injury or death.

If the engine stops or will not start, if the power steering stops working (if equipped), or if you experience other electrical failures, a fuse may need replacement. Locate and correct any short circuits that may have caused the blown fuse, then replace the fuse.

There are two fuse/relay centers accessible on the vehicle.

*For two-seat vehicles,* the primary fuse center ① is beneath the armrest and can be accessed by removing the bed of the armrest storage compartment.

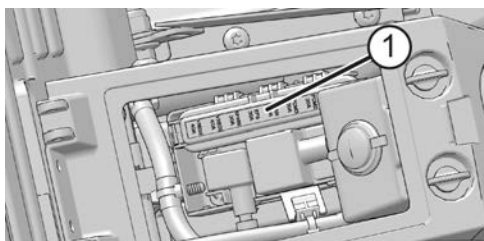

*For four-seat vehicles,* the primary fuse center ① is in the rear center console and can be accessed by removing the cover.

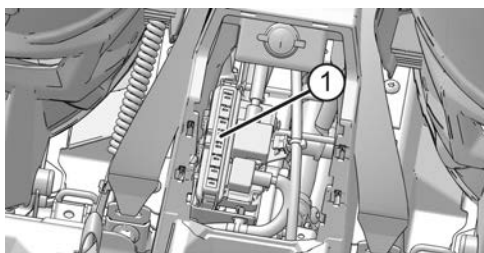

**PRIMARY FUSE CENTER**

LABEL	VALUE	FUNCTION
FAN	30A MCASE Fuse	Engine Cooling Fan
PDM 1	40A MCASE Fuse	Power to Secondary Fuse Center for Lights, Instrumentation, Audio Amp Fuse, and Accessory Relay
PDM 2	30A MCASE Fuse	Power to Secondary Fuse Center for Auxiliary Outlets, Chassis, SCM, and Shock Fuse

## MAINTENANCE

PRIMARY FUSE CENTER		
LABEL	VALUE	FUNCTION
PDM 3	30A MCASE Fuse	Power to Secondary Fuse Center for Fuel, LCAC, and EFI Fuse
EPS	30A MCASE Fuse	Electronic Power Steering
VREG 1	40A MCASE Fuse	Voltage Regulator (Left)
VREG 1	40A MCASE Fuse	Voltage Regulator (Right)
PULSE PWR	200A ZCASE Fuse	Battery Power to Polaris Pulse and 6AWG Cable

The secondary fuse center② is under the dash, near the operator's right knee area.

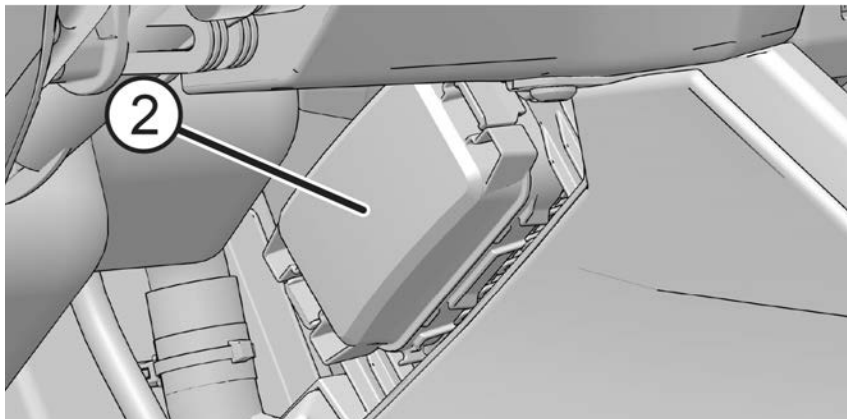

SECONDARY FUSE CENTER		
LABEL	VALUE	FUNCTION
LCAC	7.5A Fuse	Water Pump
FUEL	10A Fuse	Fuel Pump
TERM BLK	10A Fuse	Terminal Block Accessory

<b>SECONDARY FUSE CENTER</b>		
<b>LABEL</b>	<b>VALUE</b>	<b>FUNCTION</b>
INST ACCY	5A Fuse	Diagnostic Accessory, Interior LED Light, Display Accessory (optional)
PWR PT 1	10A Fuse	12V Socket (in front of gear selector)
EPS	30A Fuse	Power Steering
INST UNSW	7.5A Fuse	Display (optional), Gauge, Diagnostic
LIGHTS	7.5A Fuse	Headlights, Taillights, Accent Lights (optional), Brake Lights
CHASSIS	7.5A Fuse	AWD Switch Light, Oxygen Sensor Heater, EPS Wake-Up, Vehicle Speed Sensor, Seat Belt Switch, SCM Wake-Up (optional), SCM Mode Switch (optional), AWD Coil, Gauge, Waste Gate
EFI	10A Fuse	Accessory Relay Coil, ECM Wake-Up, Pump Relay Coil, Chassis Relay Coil, Start Relay Coil, EFI Relay Coil, Injectors, SCM Relay Coil (optional), Lights Relay Coil, Ignition Coil, Starter Solenoid Coil, Brake Relay Coil
COIL	7.5A Fuse	Coil on Plug
Additional Fuses (if equipped)		
SCM	5A Fuse	Shock Control Module
SHOCK	5A Fuse	Shock Power
AUD AMP	15A Fuse	Audio Amplifier

### COOLING SYSTEM

#### CAUTION

Escaping steam can cause burns. Never remove the pressure cap while the engine is warm or hot. Always allow the engine to cool before removing the pressure cap.

The engine coolant level is maintained by a remote pressurized tank system. The remote pressurized tank is connected to both radiators and provides a single pressure cap and fill point for the vehicle.

#### NOTE

The cooling system can cause audible liquid flowing noises as the vehicle cools down after operation. This is considered normal for the vehicle.

The pressure tank is designed to contain a volume of air above the coolant level. As coolant operating temperature increases the coolant level in the pressure tank will rise and push out air past the pressure cap. As the engine coolant temperature decreases the coolant level in the pressure tank will lower and draw air back into the tank through the pressure cap.

#### TIP

Some coolant level drop on new vehicles is normal as the system is purging itself of trapped air. Observe coolant levels and maintain cold coolant level as recommended by adding coolant to the pressure tank.

### RADIATOR COOLANT LEVEL / CHANGING COOLANT

The changing coolant procedure is required only if the cooling system has been drained for maintenance and/or repair. Ensure vehicle is parked on a level surface before servicing.

#### CAUTION

Escaping steam can cause burns. Never remove the pressure cap while the engine is warm or hot. Always allow the engine to cool before removing the pressure cap.



1. If only needing to check coolant level, there is a view① from driver's side rear fender. A flashlight may be needed. The coolant level can also be viewed by removing the cargo box.

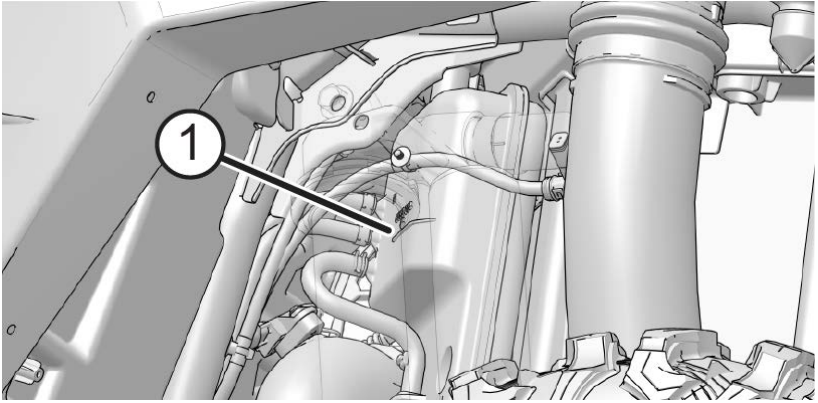

## TIP

Ensure engine has cooled off prior to checking.

2. To add coolant, begin by removing bottle access cover② in rear of vehicle.

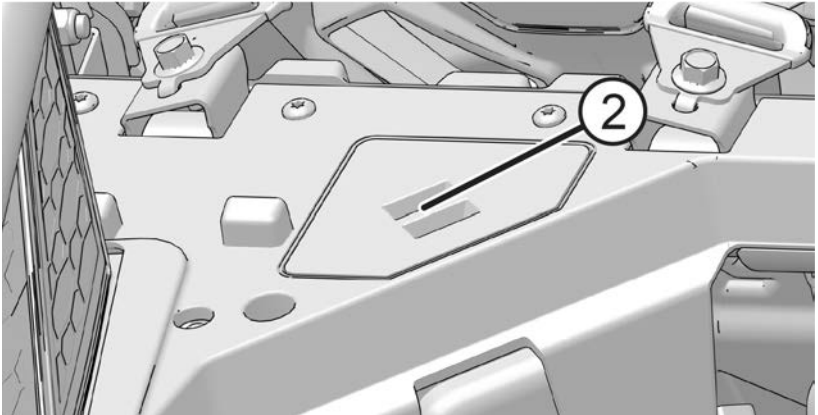

## MAINTENANCE

3. On four-seat models equipped with audio speakers, the access cover is blocked by the rear driver-side speaker. To remove, rotate the thumbscrew<sup>③</sup> and lift the speaker from the bracket.

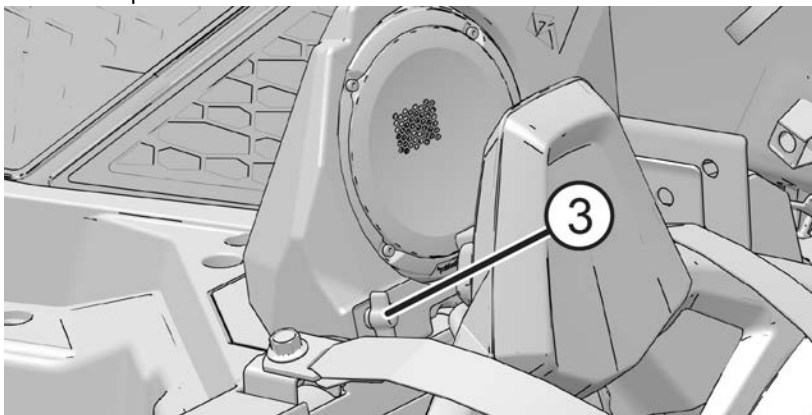

4. Slowly remove the radiator pressure cap<sup>④</sup>.

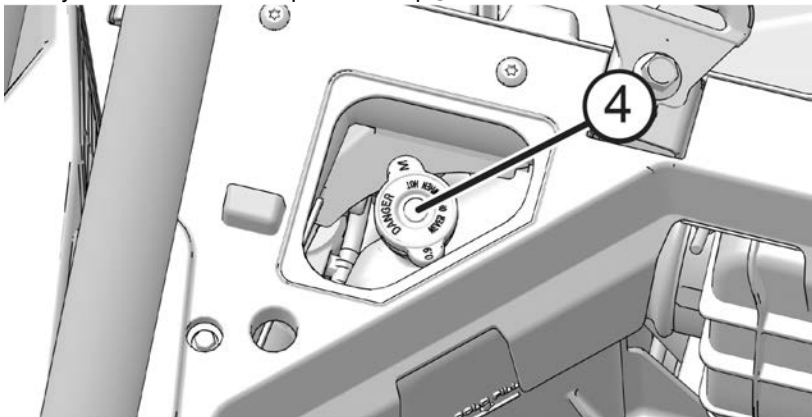

5. Remove the pressure cap and use a funnel to add coolant as needed. Maintain the coolant level within one inch (2.5 cm) of the cold fill mark on the side of the pressure tank (only when the fluid has cooled, if after operation).
6. Reinstall the pressure cap and the bottle access cover.

### TIP

Use of a non-standard pressure cap will not allow the recovery system to function properly. Your authorized dealer can provide the correct replacement part.

**TIP**

If coolant must be added often, or if the pressure tank runs completely dry, there may be a leak in the system. Your authorized dealer can inspect the cooling system.

**ADDING OR CHANGING COOLANT**

POLARIS recommends the use of POLARIS Antifreeze 50/50 Premix. This antifreeze is already premixed and ready to use. Do not dilute with water. See the Polaris Products section for the part numbers.

To ensure that the coolant maintains its ability to protect the engine, we recommend that the system be completely drained every five (5) years and fresh Antifreeze 50/50 Premix added.

Any time the cooling system has been drained for maintenance or repair, replace the coolant with fresh Antifreeze 50/50 Premix.

**RADIATORS AND COOLING FAN**

Always check and clean the screens and radiator fins at the intervals outlined in the Periodic Maintenance Chart section. Do not obstruct or deflect air flow through the radiators by installing unauthorized accessories in front of the radiators or behind the cooling fan. Interference with radiator air flow can lead to overheating and consequent engine damage.

**NOTICE**

Washing the vehicle with a high-pressure hose could damage radiator fins and impair a radiator's effectiveness. Using a high-pressure system is not recommended.

# POLARIS VARIABLE TRANSMISSION (PVT) SYSTEM

### WARNING

Failure to comply with the instructions in this warning can result in severe injury or death.

Do not modify any component of the PVT system. Doing so may reduce its strength so that a failure may occur at a high speed. The PVT system has been precision balanced. Any modification will cause the system to be out of balance, creating vibration and additional loads on components.

The PVT system rotates at high speeds, creating large amounts of force on clutch components. As the owner, you have the following responsibilities for your own safety and the safety of others:

- Always follow all recommended maintenance procedures. Always look for and remove debris inside and around the clutch and vent system when replacing the belt.
- See your dealer or other qualified service person as recommended in the owner's manual and on safety labels.
- This PVT system is intended for use on POLARIS products only. Do not install it in any other product.
- Always make sure the PVT housing is securely in place during operation.

Belt slip is responsible for creating excessive heat that destroys belts, wears clutch components and causes outer clutch covers to fail. Switch to low range while operating at slower speeds to extend the life of the PVT components (belt, cover, etc.).

## BELT REPLACEMENT / DEBRIS REMOVAL

If a belt fails, always clean any debris from the outlet duct and from the clutch and engine compartments when replacing the belt.

### WARNING

Failure to remove ALL debris when replacing the belt could result in vehicle damage, loss of control and severe injury or death.

1. Allow hot components to cool before performing this procedure.
2. Remove the engine access panel and thoroughly clean ALL debris from the engine compartment.

### NOTE

If the vehicle is on solid ground, removal of the left rear wheel or shock is not necessary for belt replacement. If the vehicle is on a lift, the shock must be removed in order to remove the clutch cover.

3. Loosen the clamp ① retaining the PVT inlet duct to the outer clutch cover.
4. Remove the fourteen (14) clutch cover screws ②.

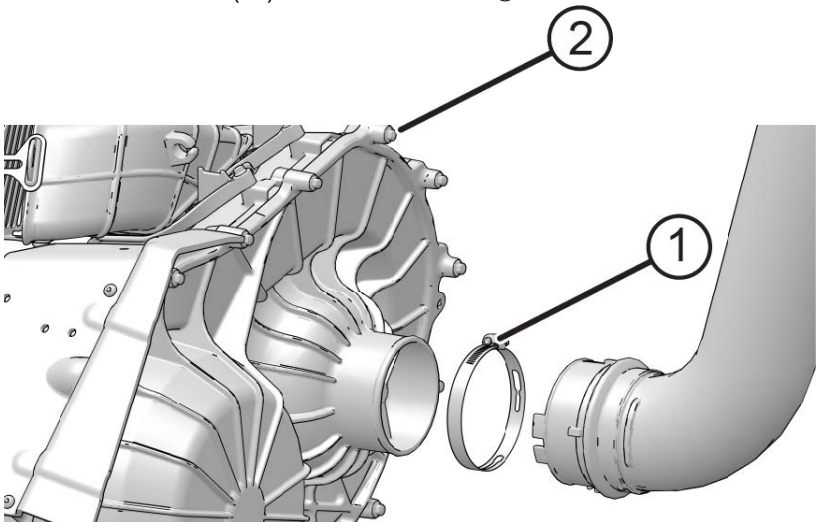

5. Maneuver the outer clutch cover outward to access the drive belt.
6. Mark the drive belt direction of rotation so that it can be installed in the same direction.

## MAINTENANCE

---

7. Insert the clutch spreader tool ③ into the driven clutch. The tool is provided in the tool kit.

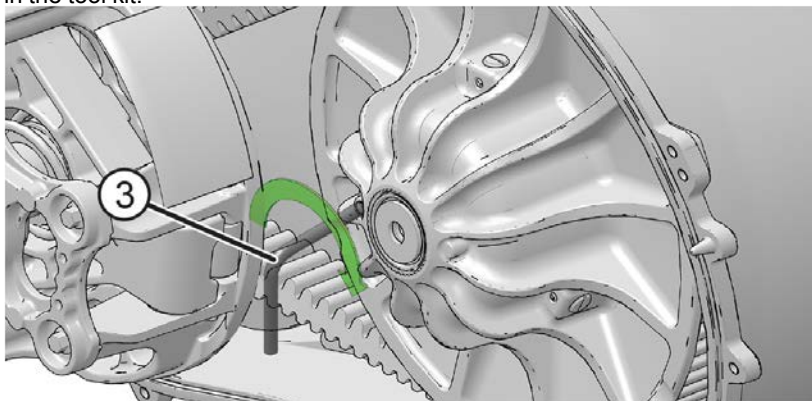

8. Turn the tool clockwise to open the sheaves on the driven clutch.
9. Walk the belt out of the driven and drive clutch. Remove the belt.
10. Remove **ALL** debris wrapped in and around the PVT system.
11. Remove **ALL** debris from the entire clutch air duct passage.
12. Check for signs of damage to seals on the transmission and engine. If any seals appear to be damaged, your vehicle requires prompt service. Your POLARIS dealer can assist.

### TIP

Belt slip is responsible for creating excessive heat that destroys belts, wears clutch components and causes outer clutch covers to fail. Switch to low range while operating at slower speeds to extend the life of the PVT components (belt, cover, etc.). Prolonged operation with heavy loads or at high speeds can shorten belt life.

## PVT DRYING

There may be some instances when water is accidentally ingested into the PVT system. Use the following instructions to dry it out before operating.

### NOTICE

When washing the vehicle, always avoid spraying water directly toward the PVT intake duct. See the Washing the Vehicle section for details.

1. Remove the clutch cover drain plug.
2. Allow the water to drain. Reinstall the drain plug.
3. Place the transmission in PARK. Apply the brakes.
4. Start the engine.
5. Apply varying throttle for 10-15 seconds to expel the moisture and air-dry the belt and clutches. Do not hold the throttle wide open for more than 10 seconds.
6. Allow the engine RPM to settle to idle speed. Apply the brakes. Shift the transmission to the lowest available range.
7. Test for belt slippage. If the belt slips, repeat the process.
8. Your vehicle requires service as soon as possible. Your POLARIS dealer or authorized person can assist.

### FILTER SYSTEMS

#### INTAKE PRE-FILTERS

The clutch air intake ① is located on the left side of the vehicle. The engine intake pre-filter ② is located on the right side of the vehicle.

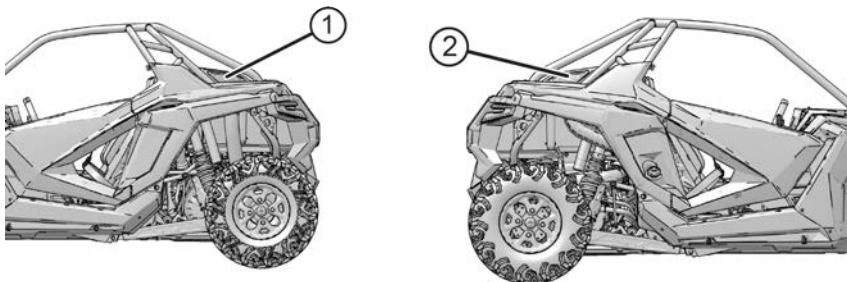

Inspect the engine pre-filter before each use of the vehicle to ensure adequate air flow. If necessary, remove the pre-filter and clean with soapy water. Dry with low pressure compressed air.

Periodically inspect the clutch (PVT) air intake for debris and clean as needed to ensure adequate air flow.

#### TIP

When washing the vehicle, always avoid spraying water directly toward the PVT intake. If water is sprayed into the PVT intake, follow the procedures in the PVT Drying section. See the Washing the Vehicle section for recommended washing procedures.



## AIR FILTER

### WARNING

Be sure to replace all vehicle components as before once finished servicing the air filter. Improper thermal protection creates a fire hazard and can lead to injury or death.

Always change the air filter at the intervals outlined in the Periodic Maintenance Chart.

1. Remove the close-off panel between the seats.
2. Clean all dirt and debris from the air box area.
3. Unlatch the five (5) air box cover clips  and carefully remove the air box cover.

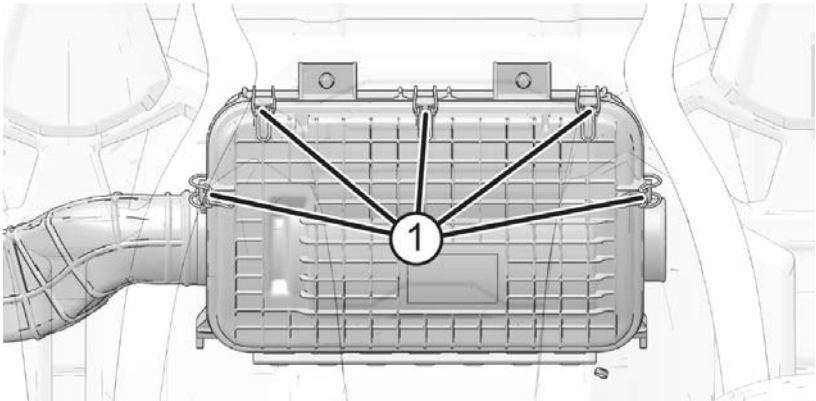

4. Inspect the air filter  and air box for dirt, debris or water.

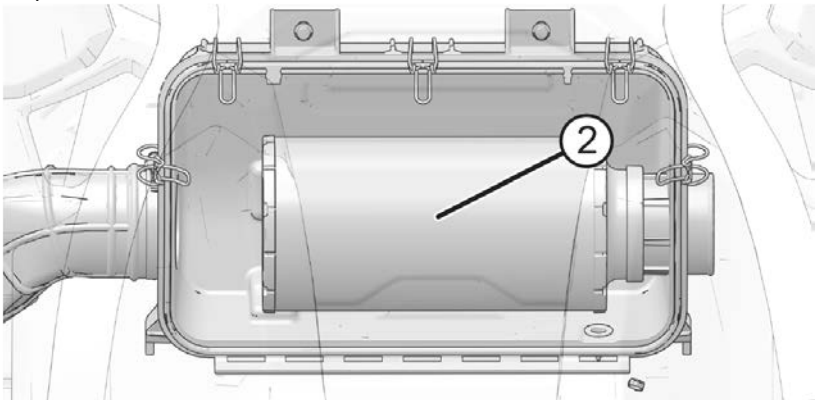

## MAINTENANCE

---

5. To remove the filter, slide the filter toward the passenger's side of the vehicle.
6. With the filter removed, clean the intake tube and air box thoroughly. Wipe well with a clean, dry cloth.

### NOTICE

Dirt or debris in the intake tube could result in severe engine damage. Always clean all dirt and debris from the intake tube before installing the filter.

7. Reinstall the air filter (if clean) or install a new air filter (if soiled). Do not attempt to clean the air filter.

### NOTICE

Use of a non-POLARIS-approved air filter may cause engine damage. Always use a POLARIS-approved replacement filter. Replacement filters are available at your POLARIS dealer.

8. Make sure that there are no gaps between the filter, the filter ring and the stop on the intake tube.
9. Reinstall the air box cover and ensure the alignment tabs are properly positioned.
10. Secure the five (5) cover clips.
11. Reinstall the close-off panel.

## SPARK ARRESTER

### WARNING

- Never operate the vehicle without the spark arrester.
- Remove any combustible materials from the area.

**Failure to heed the following warnings while servicing the spark arrester could result in serious injury or death.**

- Never run the engine in an enclosed area. Exhaust contains poisonous carbon monoxide gas that can cause loss of consciousness or death in a very short time.
- Do NOT perform service on the spark arrester while the system is HOT. Exhaust system temperatures can reach extreme temperatures. Allow components to cool sufficiently before proceeding.
- Do not stand behind or in front of the vehicle while purging the exhaust system.
- Never go under the vehicle while it is inclined.
- Wear eye protection and gloves while servicing.

Periodically clean the spark arrester to remove accumulated carbon. A plugged spark arrester will affect engine performance. Clean daily when driving in mud and water. Replace a cracked or damaged arrester before operating.

1. Remove the arrester retaining bolt ① and nut ②.
2. Remove the arrester from the end of the muffler ③.
3. Use a non-synthetic brush to clean the arrester screen ④. A synthetic brush may melt if components are warm. If necessary, blow debris from the screen with compressed air.

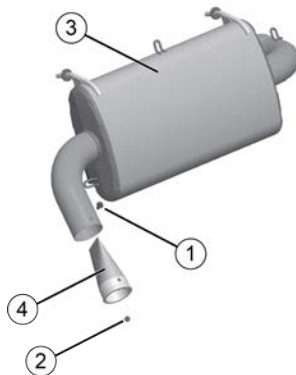

## MAINTENANCE

---

4. Inspect the screen for wear and damage. Replace a worn or damaged screen.
5. Reinstall the arrester. Torque bolt to 7-9 ft. lbs. (9-12 Nm).

---

## BRAKES

 **WARNING**

Operating the vehicle with a spongy brake pedal can result in loss of braking, which could cause an accident resulting in severe injury or death. Never operate the vehicle with a spongy-feeling brake pedal.

The front and rear brakes are hydraulic disc type brakes activated by the brake pedal.

 **CAUTION**

Brake discs can become extremely hot after operation. Allow the discs to cool before performing maintenance to prevent risk of burns.

Always check brake pedal travel and the brake fluid reservoir level before each use of the vehicle. When applied, the brake pedal should feel firm. Any sponginess would indicate a possible fluid leak or low brake fluid level, which must be corrected before riding. See the Brake Fluid section for further details.

If you discover any irregularities in brake system operation, including excessive pedal travel, contact your dealer for proper diagnosis and repairs.

### BRAKE INSPECTION

#### WARNING

Do not apply WD-40 or any petroleum product to brake discs. These types of products are flammable and may also reduce the friction between the brake pad and caliper.

1. Check the brake system for fluid leaks.
2. Check the brake pedal for excessive travel or a spongy feel.
3. Check the friction pads for wear, damage and looseness.
4. Check brake discs for signs of cracks, excessive corrosion, warping or other damage. Clean any grease using an approved brake cleaner or alcohol.
5. Inspect the brake disc spline and pad wear surface for excessive wear. Change pads when worn to 0.180" (4.6 mm) ①.

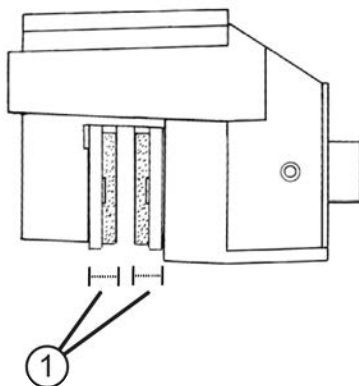

## BRAKE FLUID

### WARNING

After opening a bottle of brake fluid, always discard any unused portion. Never store or use a partial bottle. Brake fluid is hygroscopic, meaning it rapidly absorbs moisture from the air. The moisture causes the boiling temperature of the brake fluid to drop, which can lead to early brake fade and the possibility of accident or severe injury.

Inspect the level of the brake fluid before each operation. If the fluid level is low add DOT 4 brake fluid only. See the Polaris Products section for the part numbers.

Change the brake fluid every two years and any time the fluid becomes contaminated, the fluid level is below the minimum, or if the type and brand of the fluid in the reservoir are unknown. Access the brake fluid reservoir through the left front wheel well.

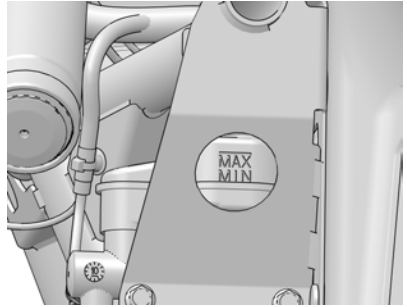

1. Position the vehicle on a level surface.
2. Place the transmission in PARK.
3. View the brake fluid level in the reservoir, located in the front driver-side wheel well. The level should be between the maximum and minimum level lines.
4. If the fluid level is lower than the lower level line, add brake fluid to the upper line.
5. Apply the brake forcefully for a few seconds and check for fluid leakage around the fittings.

## SUSPENSION SYSTEM

### SHOCK ADJUSTMENT RECOMMENDATIONS

 **WARNING**

Be advised that the shocks contain nitrogen at high pressure. Damaged shocks could cause injury if not replaced or addressed promptly by qualified personnel.

 **CAUTION**

Keep other individuals away from the vehicle when adjusting the shocks. Boarding the vehicle creates sudden shock compression, which can cause pinched fingers during maintenance.

#### SHOCK ADJUSTMENTS

##### RZR ProXP

Weight Condition <i>assuming each rider, wearing gear, is 215 lbs. (97.5 kg)</i>		Spring Preload Adjustment
Riders	<b>Cargo + Accessories</b>	<i>Shaded cells indicate factory settings</i>
Driver only	0	Remove 0.25 inch (6.4 mm) preload, front and rear
Driver + 1	0	Factory default preload
Driver + 1	100 lbs. (45 kg)	Add 0.25 inch (6.4 mm) preload, front and rear
Driver + 1	200 lbs. (91 kg)	Add 0.5 inch (12.7 mm) preload, front and rear
Driver + 1	300 lbs. (136 kg)	Add 0.75 inch (19.1 mm) preload, front and rear



<b>SHOCK ADJUSTMENTS</b>		
<b>RZR ProXP 4</b>		
<b>Weight Condition</b> <i>assuming each rider, wearing gear, is 215 lbs. (97.5 kg)</i>		<b>Spring Preload Adjustment</b>
<b>Riders</b>	<b>Cargo + Accessories</b>	<i>Shaded cells indicate factory settings</i>
Driver only	0	Remove 0.4 inch (10 mm) preload, front and rear
Driver + 2	40 lbs. (18 kg)	Factory default preload
Driver + 3	40 lbs. (18 kg)	Add 0.4 inch (10 mm) preload, front and rear

## MAINTENANCE

### FRONT / REAR SPRING PRELOAD ADJUSTMENT

1. Elevate the vehicle to allow the suspension to fully extend.
2. Turn the adjusting ring to the left to add preload. Turn the adjusting ring to the right to remove preload. If equipped, apply the locking ring when desired preload is adjusted.

#### WARNING

Uneven adjustment may cause poor handling of the vehicle, which could result in an accident. Always adjust both the left and right spring preloads equally or have your POLARIS dealer or qualified person perform the adjustments.

#### DYNAMIX SHOCKS

- ① Front Shock Preload Measurement
- ② Rear Shock Preload Measurement

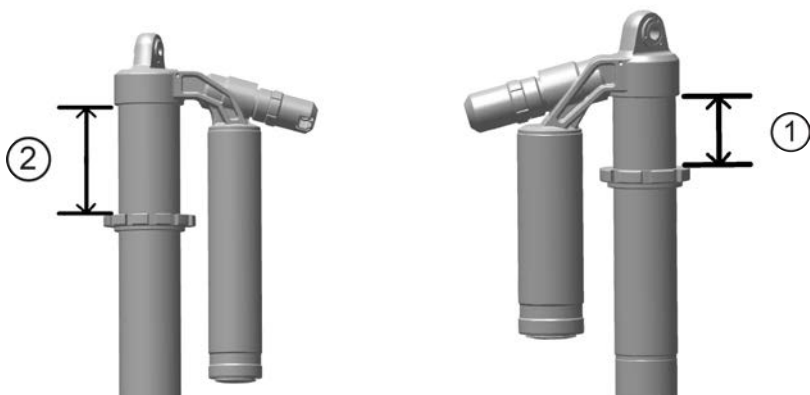

**FACTORY DEFAULT PRELOAD SETTINGS**

<b>FACTORY DEFAULT PRELOAD SETTINGS</b>		
<b>RZR ProXP</b>	<b>DYNAMIX</b>	
	Front	3.06 inches (7.8 cm)
	Rear	10.79 inches (27.4 cm)
	<b>NON-DYNAMIX</b>	
	Front	2.90 inches (7.4 cm)
	Rear	8.30 inches (21.1 cm)
<b>RZR ProXP 4</b>	<b>DYNAMIX</b>	
	Front	3.22 inches (8.2 cm)
	Rear	9.25 inches (23.5 cm)
	<b>NON-DYNAMIX</b>	
	Front	2.58 inches (6.6 cm)
	Rear	6.23 inches (15.8 cm)

## MAINTENANCE

---

### FRONT / REAR SHOCK COMPRESSION ADJUSTMENT

The compression damping clicker knob is located at the top of the shock reservoir.

1. Turn the clicker **clockwise** to **increase** compression damping.
2. Turn the clicker **counter-clockwise** to **decrease** compression damping.

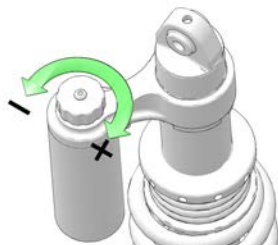

Location	Clicker Position
Front	8/16 clicks
Rear	8/16 clicks

## TIRES

### WARNING

Operating your vehicle with worn tires will increase the possibility of skidding, loss of control and an accident, which could result in serious injury or death. Always replace tires when the tread depth measures 3 mm (1/8") or less.

Improper tire inflation or the use of non-standard size or type of tires may adversely affect vehicle handling, which could result in vehicle damage or personal injury. Always maintain proper tire pressure. Always use POLARIS-approved size and type of tires for this vehicle when replacing tires.

### TIRE TREAD DEPTH

Always replace tires when tread depth is worn to 1/8" (3 mm) ① or less.

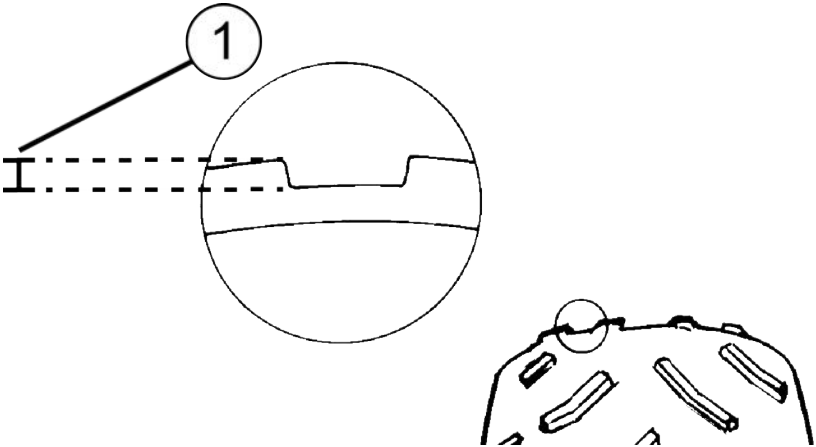

## MAINTENANCE

---

### TIRE ROTATION

Tire rotation is recommended for every 500-mile (805-km) interval. Perform tire rotation on the vehicle by the strategy as shown.

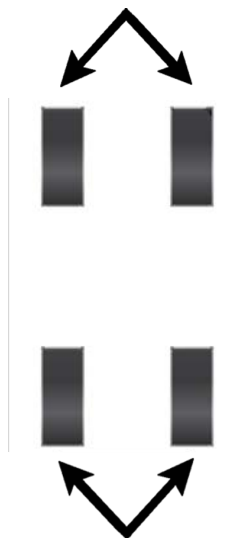

### AXLE AND WHEEL NUT TORQUE SPECIFICATIONS

Inspect the following items occasionally for tightness, and if they've been loosened for maintenance service. *Do not lubricate the stud or the lug nut.*

Lug Nut (Aluminum Wheels)	Front and Rear	120 ft-lbs (162.7 Nm)
Hub Retaining Nut	Front and Rear	180 ft-lbs. (244 Nm)

### WHEEL REMOVAL

1. Position the vehicle on a level surface.
2. Place the transmission in PARK.
3. Stop the engine.
4. Loosen the wheel nuts slightly.
5. Elevate the side of the vehicle by placing a suitable stand under the frame.
6. Remove the wheel lug nuts. Remove the wheel.

## WHEEL INSTALLATION

### WARNING

Improperly installed wheels can adversely affect tire wear and vehicle handling, which can result in serious injury or death. Always ensure that all nuts are torqued to specification. Do not service axle nuts that have a cotter pin installed. Your POLARIS dealer can assist.

1. Place the transmission in PARK.
2. Place the wheel in the correct position on the wheel hub. Be sure the valve stem ① is toward the outside and rotation arrows on the tire point toward forward rotation.
3. Attach the wheel nuts and finger tighten.
4. Carefully lower the vehicle to the ground.
5. Torque the wheel nuts to specification. See the Axle and Wheel Nut Torque Specifications section for details.



Right Rear Wheel  
(type varies by model)

### LIGHTS

Headlight and taillight lenses become dirty during normal operation. Clean all lights frequently to ensure a clear field of vision as well as visibility to other vehicles.

#### TIP

##### LED LAMPS

If an LED headlamp has moisture or fogging inside, disconnect the wiring harness from the headlamp(s) for a few days to allow the moisture to clear out.

#### TIP

##### HALOGEN LAMPS

When servicing a halogen lamp, don't touch the lamp with bare fingers. Oil from your skin leaves a residue, causing a hot spot that will shorten the life of the lamp.

### TAILLIGHT / BRAKE LIGHT REPLACEMENT

The taillight assembly is not serviceable. If the taillight or brake light fails to operate properly, replace the entire taillight assembly.

### HEADLIGHT REPLACEMENT

If a headlight becomes damaged or inoperable, the entire headlight assembly must be replaced. Do not operate this vehicle at night or in low light conditions until the headlight is replaced. Always make sure lights are adjusted properly for best visibility.



## HEADLIGHT BEAM ADJUSTMENT

The headlight beam can be adjusted slightly upward or downward and to the left or right.

1. Position the vehicle on a level surface. The headlight should be approximately 25 ft. (7.6 m) from a wall.

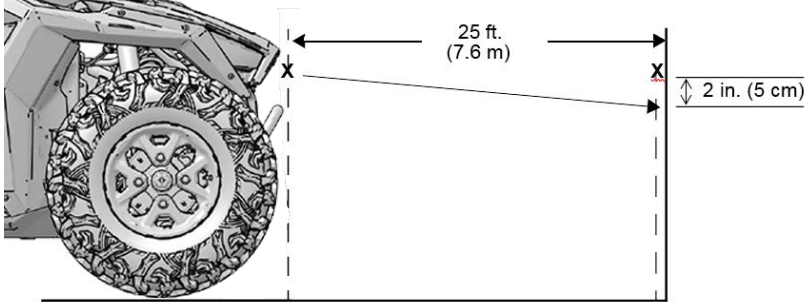

2. Place the transmission in PARK.
3. Measure the distance from the floor to the center of the headlight and make a mark on the wall at the same height.
4. Apply the brakes. Start the engine. Turn the headlights to high beam.
5. Include the weight of a rider on the seat while performing this step. Observe the headlight aim. As a starting point, the most intense part of the headlight beam should be 2 inches (5 cm) below the mark on the wall. Adjust to operator preference.
6. Tighten or loosen the two (2) headlight screws ① to adjust the beam upward or downward or to the left or right.

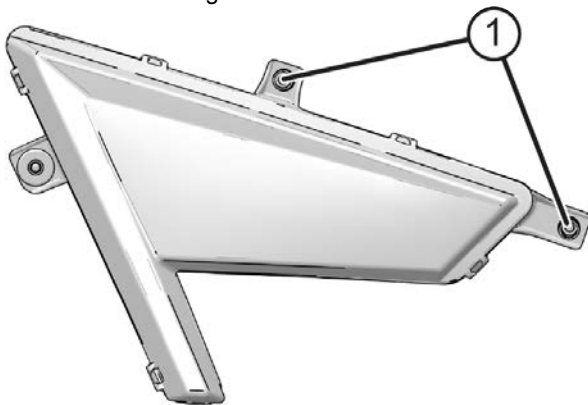

### VEHICLE IMMERSION

#### NOTICE

If your vehicle becomes immersed, major engine damage can result if the machine is not thoroughly inspected. Take the vehicle in for service before starting the engine. Your POLARIS dealer can provide this service.

If it's impossible to take your vehicle to a dealer before starting it, follow the steps outlined below.

1. Move the vehicle to dry land.
2. Check the air box. See the Air Filter section for details. If water is present, dry the air box and replace the filter with a new filter.
3. Remove the fuse/relay center cover. See the Fuse/Relay Center section for details. Allow any moisture to dry, then reinstall the cover.
4. Dry the spark plug wells with a clean cloth, then remove the spark plugs.
5. Turn the engine over several times.
6. Dry the spark plugs and reinstall them, or install new plugs.
7. Attempt to start the engine. If necessary, repeat the drying procedure.
8. Take the vehicle in for service as soon as possible, whether you succeed in starting it or not. Your POLARIS dealer can provide the required service.
9. If water has been ingested into the PVT follow the steps in the POLARIS Variable Transmission (PVT) System section for drying procedures.

### STEERING WHEEL INSPECTION

Check the steering wheel for specified freeplay and smooth operation at the intervals outlined in the Periodic Maintenance Chart.

1. Position the vehicle on level ground.
2. Lightly turn the steering wheel left and right.
3. There should be 0.8-1.0" (20-25 mm) of freeplay.
4. If there is excessive freeplay or strange noises, or if the steering feels rough or "catchy," have the steering system inspected by an authorized POLARIS dealer or other qualified personnel.

---

## BATTERY

### WARNING

Improperly connecting or disconnecting battery cables can result in an explosion and cause serious injury or death. When removing the battery, always disconnect the negative (black) cable first. When reinstalling the battery, always connect the negative (black) cable last.

Your vehicle has a low-maintenance battery. Always keep battery terminals and connections free of corrosion. If cleaning is necessary, remove the corrosion with a stiff wire brush. Wash with a solution of one tablespoon baking soda and one cup water. Rinse well with tap water and dry off with clean shop towels. Coat the terminals with dielectric grease or petroleum jelly.

### NOTE

If more amperage is required for high electrical loads, an additional battery can be added.

## BATTERY REMOVAL

1. Ensure the key switch is set to OFF position before removing the battery.
2. Remove the driver's seat. See the Seats section for details.
3. Disconnect the black (negative) battery cable first.
4. Disconnect the red (positive) battery cable last.
5. Remove the battery hold-down strap.
6. Lift the battery out of the vehicle.

## BATTERY INSTALLATION

Using a new battery that has not been fully charged can damage the battery and result in a shorter life. It can also hinder vehicle performance. Follow the instructions in the Battery Charging section before installing the battery.

1. Ensure that the battery is fully charged.
2. Place the battery in the battery holder.
3. Coat the terminals with dielectric grease or petroleum jelly.
4. Secure the battery hold-down strap.
5. Connect and tighten the red (positive) cable first.
6. Connect and tighten the black (negative) cable last.

## MAINTENANCE

---

7. Verify that cables are properly routed.
8. Reinstall the seat.

## BATTERY MAINTENANCE AND CHARGING

### WARNING

An overheated battery may explode, causing severe injury or death. Always watch charging times carefully. Stop charging if the battery becomes very warm to the touch. Allow it to cool before resuming charging.

The sealed battery is already filled with electrolyte and has been sealed and *fully charged* at the factory. *Never* pry the sealing strip off or add any other fluid to this battery.

The single most important thing about maintaining a sealed battery is to keep it fully charged. Check the battery voltage with a voltmeter or multimeter. A fully charged battery will register 12.8 V or higher. If the voltage falls below 12.5V, charge it immediately, or the battery runs the risk of sulfation and reduced battery life.

If you do not drive the vehicle for more than TWO WEEKS, Polaris recommends using a BatteryMINDER® 2012 AGM - 2 AMP charger (PN 2830438), which can be ordered through your dealer. During charging, place the charger outside of the vehicle and protect it from moisture.

### NOTICE

For added convenience Polaris offers the BatteryMINDER® Accessory Vehicle Power Plug (PN 2830518) which allows easy connection to the vehicle's battery through the 12V auxiliary outlet. The auxiliary outlet<sup>①</sup> is located center storage compartment. Use a smartphone to view the power plug accessory via the QR code below. Do not use the 12V auxiliary outlet located in the center armrest compartment - that outlet cannot be used to connect to the battery.

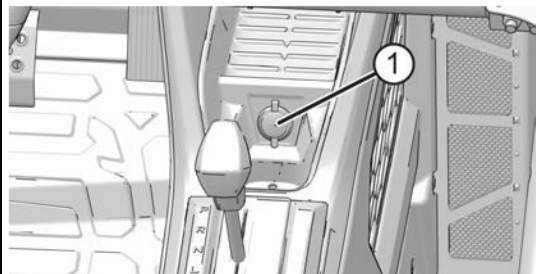

If you plan to store the vehicle for ONE MONTH or longer, remove the battery from the vehicle, then store the battery in a cool and dry location. Continue to maintain the battery with the BatteryMINDER® 2012 AGM - 2 AMP charger.

When using an automatic charger other than a BatteryMINDER 2012-AGM - 2 AMP charger, refer to the charger manufacturer's instructions for recharging.

If using a **constant current charger** (instead of BatteryMINDER® 2012 AGM - 2 AMP charger), use the guidelines below. Always verify battery condition before and 1-2 hours after the end of charging.

State of Charge	Voltage (DC)	Action	Charge Time*
100%	12.8-13.0 volts	None, check monthly	None required
75%-100%	12.6-12.8 volts	May need slight charge, if no charge given, check in 2 weeks	3-6 hours
50%-75%	12.3-12.6 volts	Needs charge	5-11 hours
25%-50%	12.0-12.3 volts	Needs charge	At least 13 hours
0%-25%	12.0 volts or less	Needs charge	At least 20 hours
* Using AGM specific charger at standard amps specified on top of battery			

# CLEANING AND STORAGE

## WASHING THE VEHICLE

Keeping your POLARIS vehicle clean will not only improve its appearance but it can also extend the life of various components.

### NOTE

All sealed storage compartments in the vehicle are element-resistant but not water-proof. Remove items from storage compartments before cleaning to avoid water damage.

### NOTICE

Water in the PVT system could cause the drive belt to become wet and slip in the clutches. Always avoid spraying water directly toward any intake pre-filters<sup>①</sup>. If water is sprayed into the pre-filters, perform the drying procedures described in the PVT Drying section.

High water pressure may damage radiator fins and impair a radiator's effectiveness. High pressure may also damage other vehicle components.

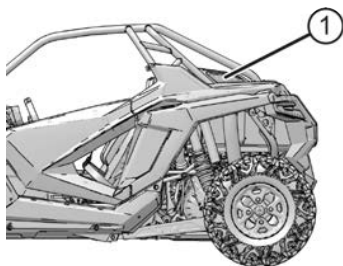

Certain products, including insect repellents and chemicals, will damage plastic surfaces. Do not allow these types of products to contact the vehicle.

The best and safest way to clean your POLARIS vehicle is with a garden hose and a pail of mild soap and water.

1. Use a professional-type washing cloth, cleaning the upper body first and the lower parts last.
2. Rinse with clean water frequently.
3. Dry surfaces with a chamois to prevent water spots.

If a high pressure water system is used for cleaning (not recommended), exercise extreme caution. The water may damage components and could remove paint and labels. Avoid directing the water stream at the following items:

- Wheel bearings
- Radiators
- Transmission seals
- Brakes
- Cab and body panels
- Labels and decals
- Electrical components and wiring
- Air intake components

If warning and safety labels are damaged, contact your POLARIS dealer for free replacement.

Grease all zerk fittings immediately after washing. Allow the engine to run for a while to evaporate any water that may have entered the engine or exhaust system.

### **WASHING TIPS**

- Avoid the use of harsh cleaners, which can scratch the finish.
- Do not use a power washer to clean the vehicle.
- Do not use medium to heavy duty compounds on the finish.
- Always use clean cloths and pads for cleaning and polishing. Old or reused cloths and pads may contain dirt particles that will scratch the finish.

### **POLISHING THE VEHICLE**

POLARIS recommends the use of common household aerosol furniture polish for polishing the finish on your POLARIS vehicle. Follow the instructions on the container.

### **POLISHING TIPS**

- Avoid the use of automotive products, some of which can scratch the finish of your vehicle.
- Always use clean cloths and pads for cleaning and polishing. Old or reused cloths and pads may contain dirt particles that will scratch the finish.

### STORAGE TIPS

#### NOTICE

Starting the engine during the storage period will disturb the protective film created by fogging and damage could occur. Never start the engine during the storage period.

#### **CLEAN THE EXTERIOR**

Make any necessary repairs and clean the vehicle as recommended. See the Washing the Vehicle section for details.

#### **STABILIZE THE FUEL**

1. Fill the fuel tank.
2. Add POLARIS Carbon Clean Fuel Treatment or POLARIS Fuel Stabilizer or equivalent fuel treatments or stabilizers. Follow the instructions on the container for the recommended amount. Carbon Clean removes water from fuel systems, stabilizes fuel and removes carbon deposits from pistons, rings, valves and exhaust systems.
3. Allow the engine to run for 15-20 minutes to allow the stabilizer to disperse through the entire fuel delivery system.

#### **OIL AND FILTER**

Change the oil and filter. See the Oil and Filter Change section for details.

#### **AIR FILTER / AIR BOX**

Replace the air filter. See the Air Filter section for details. Clean the air box.

#### **FLUID LEVELS**

Inspect the fluid levels. Add or change fluids as recommended in the Periodic Maintenance Chart section.

- Demand drive fluid (front gearcase)
- Rear gearcase fluid (if equipped)
- Transmission fluid
- Brake fluid (change every two years and any time the fluid looks dark or contaminated)
- Coolant (test strength/fill)

#### **INSPECT AND LUBRICATE**

Inspect all cables and lubricate all areas of the vehicle as recommended in the Periodic Maintenance Chart section.



### **FOG THE ENGINE**

1. Treat the fuel system with POLARIS Carbon Clean or other equivalent fuel treatment. Follow the instructions on the container. Start the engine. Allow it to idle for several minutes so the Carbon Clean reaches the injectors. Stop the engine.
2. Remove the spark plugs and add 2-3 tablespoons of engine oil. To access the plug holes, use a section of clear 1/4" hose and a small plastic squeeze bottle filled with the pre-measured amount of oil. *Do this carefully! If you miss the plug holes, oil will drain from the spark plug cavities into the hole at the front of the cylinder head, and appear to be an oil leak.*
3. Reinstall the spark plugs. Torque to specification. See the Spark Plug Gap / Torque section for details.
4. Apply dielectric grease to the inside of each spark plug cap. *Do not reinstall the caps onto the plugs at this step.*
5. Turn the engine over several times. Oil will be forced in and around the piston rings and ring lands, coating the cylinder with a protective film of fresh oil.
6. If POLARIS fuel system additive is not used, fuel tank, fuel lines, and injectors should be completely drained of gasoline.
7. Reinstall the spark plug caps to the spark plugs.

### **BATTERY MAINTENANCE**

See Battery section for storage and charging procedures.

### **FUSE BOX**

Remove the fuse box cover during storage.

### **STORAGE AREA / COVERS**

Be sure the storage area is well ventilated. Cover the vehicle with a genuine POLARIS cover. Do not use plastic or coated materials. They do not allow enough ventilation to prevent condensation, and may promote corrosion and oxidation.

### **REMOVAL FROM STORAGE**

1. Charge the battery if necessary.
2. Make sure the spark plug is tight. Reinstall the fuse box cover if it was removed for storage.
3. Fill the fuel tank with fuel.

## MAINTENANCE

---

4. Check all the points listed in the Daily Pre-Ride Inspection section. Tightness of the bolts, nuts and other fasteners should be checked by an authorized POLARIS dealer or other qualified service facility.
5. Lubricate at the intervals outlined in the Periodic Maintenance Chart section.

 **WARNING**

Engine exhaust contains poisonous carbon monoxide and can cause loss of consciousness or death. Never run an engine in an enclosed area.

## TRANSPORTING THE VEHICLE

### WARNING

Cargo and other loose vehicle parts may fly off while transporting this vehicle. Secure or remove all cargo, and inspect the unit for loose parts prior to transport.

If transporting the vehicle in a non-enclosed trailer, then the vehicle must FACE FORWARD, or roof must be removed.

Failure to comply may allow airflow, vibration, or other factors to separate the roof from the vehicle and cause an accident, resulting in serious personal injury or death.

### NOTE

For functional descriptions detailing how to operate the DYNAMIX suspension system on certain vehicle models, consult the Polaris *RideCommand* manual.

Follow these procedures when transporting the vehicle.

### NOTICE

After a ride, allow the engine to idle for 30 seconds before stopping the engine. This will allow the turbo system to cool down.

1. Place the transmission in PARK.
2. Stop the engine. Turn the key back on to the accessory or ON position without starting the engine. Slowly release the brake pedal and make sure the transmission is in PARK before exiting the vehicle, verifying that the PARK position is shown on the display.
3. Prior to securing the vehicle, the key switch must remain in the ON position, the suspension mode switch must be in the COMFORT setting, and the demo mode timeout must not be active while securing the vehicle. Shock damping settings can be verified on the Suspension visualization screen.
4. Secure the vehicle.

### WARNING

Vehicles equipped with DYNAMIX active suspension must be powered on, set to COMFORT mode, and properly functioning in order to ensure the shocks are operating at their minimum compression damping setting prior to securing the vehicle for transport. Failure to ensure the shocks are in their minimum compression damping setting prior to securing the vehicle can potentially lead to a reduction of intended strap tension while trailering.

## MAINTENANCE

---

5. After the vehicle has been secured, verify the gauge indicates PARK, and turn the vehicle power off. Verify also that the suspension compression damping values are still soft after securing the vehicle. If after securing the suspension demo mode has timed out or the suspension has moved to a FIRM setting as indicated on the Suspension control screen, cycle the key switch, place the mode switch in COMFORT mode, and re-tighten the straps per step number 3.
6. Remove the key to prevent loss during transporting. Secure the fuel cap and seats. Ensure that the seats are attached correctly and are not loose.

### WARNING

Cargo and other loose vehicle parts may fly off while transporting this vehicle. Secure or remove all cargo, and inspect the unit for loose parts prior to transport.

7. Always tie the frame of the POLARIS vehicle to the transporting unit securely with suitable straps or rope. Do not attach tie straps to the front control arm bolt pockets.

#### ① Rear Tie-Down (both sides)

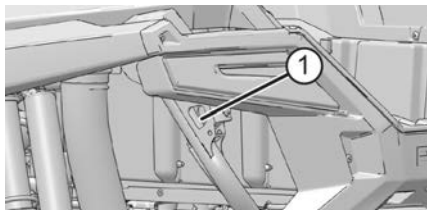

#### ② Front Tow Loop Tie-Down

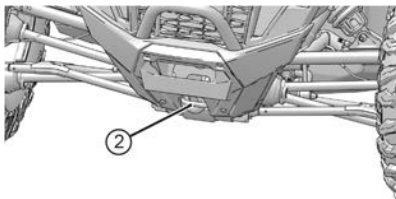

## SPECIFICATIONS

## RZR PROXP

Gross Vehicle Weight*	Base: 2582 lbs. (1171.2 kg) LE: 2628 lbs. (1192.0 kg)
Dry Weight*	Base: 1745 lbs. (791.5 kg) LE: 1790 lbs. (811.9 kg)
*Dry weight is also listed on the Certificate of Origin for your vehicle in the Shipping Weight field. The dry weight is estimated based on the manufactured weight of the vehicle minus any serviceable fluids and may also exclude the weight of factory installed accessories not essential to the vehicle's basic operation as outlined in the ANSI/ROHVA 1-2016 standard.	
Test GVW - Rollover Protection System (ROPS)	2850 lbs. (1292.7) per OSHA 1928.53
Rear Cargo Box Capacity	300 lbs. (136 kg)
Maximum Weight Capacity (Payload)	740 lbs. (336 kg) (including riders, cargo and accessories)
Fuel Capacity	12.0 gal. (45.4 L)
Engine Oil Capacity	2.75 qts. (2.6 L)
Coolant Capacity	11.9 qts. (11.3 L)
Demand Drive Fluid Capacity	9.5 oz. (280 ml)
Transmission Oil Capacity	61 oz. (1800 ml)
Overall Length/Width/Height	126.1 / 64.0 / 71.7 in. (320.4 / 162.6 / 182.1 cm)
Wheelbase	96 in. (243.8 cm)
Ground Clearance	14 in. (35.6 cm)
Engine	4-Stroke DOHC Twin Cylinder
Displacement	925 cc
Bore x Stroke	93mm x 68mm
Alternator Output	900W @ 3000 RPM

## SPECIFICATIONS

Compression Ratio	9.0:1
Starting System	Electric
Fuel System	Electronic fuel injection
Ignition System	ECU
Spark Plug / Gap	NGK MR9F / 0.7-0.8 mm
Front Suspension	Independent double a-arm with 17 in. (43.2 cm) travel
Rear Suspension	Independent trailing arms with 20 in. (50.8 cm) travel
Lubrication System	Wet Sump
Driving System Type	Automatic POLARIS Variable Transmission
Shift Type	Dual Range P/R/N/L/H
Tire Size - Front	30x10 R14
Tire Size - Rear	30x10 R14
Tire Pressure	Front: 10 psi (69 kPa) Rear: 20 psi (138 kPa)
Brakes, Front/Rear	Foot Activated, 4-wheel hydraulic disc
Headlights	2 dual beam LED cluster
Taillights	2 LED cluster
Brake Lights	2 LED cluster
Instrument Cluster	LCD
Auxiliary DC Outlet	12V

## RZR PROXP 4

Gross Vehicle Weight*	Base: 2932 lbs. (1330.0 kg) LE: 2989 lbs. (1355.8 kg)
Dry Weight*	Base: 1999 lbs. (906.7 kg) LE: 2055 lbs. (932.1 kg)
*Dry weight is also listed on the Certificate of Origin for your vehicle in the Shipping Weight field. The dry weight is estimated based on the manufactured weight of the vehicle minus any serviceable fluids and may also exclude the weight of factory installed accessories not essential to the vehicle's basic operation as outlined in the ANSI/ROHVA 1-2016 standard.	
Test GVW - Rollover Protection System (ROPS)	3300 lbs. (1497) per OSHA 1928.53
Rear Cargo Box Capacity	300 lbs. (136 kg)
Maximum Weight Capacity (Payload)	900 lbs. (408 kg) (including riders, cargo and accessories)
Fuel Capacity	13.0 gal. (49.2 L)
Engine Oil Capacity	2.75 qts. (2.6 L)
Coolant Capacity	11.9 qts. (11.3 L)
Demand Drive Fluid Capacity	9.5 oz. (280 ml)
Transmission Oil Capacity	61 oz. (1800 ml)
Overall Length/Width/Height	155.1 / 64.0 / 74.5 in. (394.0 / 162.6 / 189.2 cm)
Wheelbase	125 in. (318 cm)
Ground Clearance	14 in. (35.6 cm)
Engine	4-Stroke DOHC Twin Cylinder
Displacement	925 cc
Bore x Stroke	93mm x 68mm
Alternator Output	900W @ 3000 RPM
Compression Ratio	9.0:1

## SPECIFICATIONS

Starting System	Electric
Fuel System	Electronic fuel injection
Ignition System	ECU
Spark Plug / Gap	NGK MR9F / 0.7-0.8 mm
Front Suspension	Independent double a-arm with 17 in. (43.2 cm) travel
Rear Suspension	Independent trailing arms with 20 in. (50.8 cm) travel
Lubrication System	Wet Sump
Driving System Type	Automatic POLARIS Variable Transmission
Shift Type	Dual Range P/R/N/L/H
Tire Size - Front	30x10 R14
Tire Size - Rear	30x10 R14
Tire Pressure	Front: 16 psi (110 kPa) Rear: 20 psi (138 kPa)
Brakes, Front/Rear	Foot Activated, 4-wheel hydraulic disc
Headlights	2 dual beam LED cluster
Taillights	2 LED cluster
Brake Lights	2 LED cluster
Instrument Cluster	LCD
Auxiliary DC Outlet	12V



---

**OUTPUT GEAR RATIOS**

<b>Rear</b>	
High Gear	12.51:1
Low Gear	20.36:1
Reverse	26.33:1
<b>Front (including front drive)</b>	
High Gear	13.17:1
Low Gear	21.41:1
Reverse	27.71:1
Drive Ratio - Front	3.17:1

**CLUTCHING**

Please see your POLARIS dealer for clutching specifications



# POLARIS PRODUCTS

## LUBRICANTS / SERVICE PRODUCTS

PART NUMBER	DESCRIPTION
<b>Engine Lubricant</b>	
2870791	Fogging Oil (12 oz./355 ml Aerosol)
2876244	PS-4 Full Synthetic 5W-50 4-Cycle Oil (qt./95 l)
2876245	PS-4 Full Synthetic 5W-50 4-Cycle Oil (gal./3.8 l)
2878920	PS-4 Extreme Duty Synthetic 10W-50 4-Cycle Oil (qt./95 l)
2878919	PS-4 Extreme Duty Synthetic 10W-50 4-Cycle Oil (gal./3.8 l)
<b>Gearcase / Transmission Lubricants</b>	
2878068	AGL Full Synthetic Gearcase Lubricant & Transmission Fluid (qt./95 l)
2878069	AGL Full Synthetic Gearcase Lubricant & Transmission Fluid (gal./3.8 l)
2877922	Demand Drive Fluid (qt./95 l)
2877923	Demand Drive Fluid (gal./3.8 l)
2870465	Pump for Gallon (3.8 l) Jug
<b>Coolant</b>	
2880514	Antifreeze 50/50 Premix (qt./95 l)
2880513	Antifreeze 50/50 Premix (gal./3.8 l)
<b>Grease / Specialized Lubricants</b>	
2871312	Grease Gun Kit, All Season Grease
2871322	All Season Grease (3 oz./89 ml cartridge)
2871423	All Season Grease (14 oz./414 ml cartridge)
2876160	ATV Angle Drive Fluid (qt./95 l)

## POLARIS PRODUCTS

<b>PART NUMBER</b>	<b>DESCRIPTION</b>
2872276	ATV Angle Drive Fluid (2.5 gal./9.5 l)
2871460	Premium Starter Grease
2871515	U-Joint Grease (3 oz./89 ml cartridge)
2871551	U-Joint Grease (14 oz./414 ml cartridge)
2871329	Dielectric Grease (Nyogel™)
<b>Additives / Miscellaneous</b>	
2871326	Carbon Clean
2870652	Fuel Stabilizer
2872189	DOT 4 Brake Fluid
2871956	Loctite™ 565 Thread Sealant
2859044	POLARIS Battery Tender™ Charger

## TROUBLESHOOTING

### DRIVE BELT WEAR / BURN

POSSIBLE CAUSE	SOLUTION
Driving onto a pickup or tall trailer in high range	Use low range during loading.
Starting out going up a steep incline	Use low range. See warnings on page 89.
Driving at low RPM or ground speed (3-7 MPH/ 5-11 km/h)	Drive at a higher speed or use low range more frequently. See the Gear Selector section for details.
Insufficient warm-up at low ambient temperatures	Warm the engine at least 5 minutes. With the transmission in neutral, advance the throttle to about 1/8 throttle in short bursts, 5 to 7 times. The belt will become more flexible and prevent belt burning.
Slow/easy clutch engagement	Use the throttle quickly and effectively.
Hauling heavy cargo/pushing at low RPM/low ground speed	Use low range only.
Utility use/plowing	Use low range only.
Stuck in mud or snow	Shift the transmission to low range and carefully use fast, aggressive throttle application to engage clutch. <b>WARNING!</b> Excessive throttle may cause loss of control and vehicle rollover.
Climbing over large objects from a stopped position	Shift the transmission to low range and carefully use fast, brief, aggressive throttle application to engage clutch. <b>WARNING!</b> Excessive throttle may cause loss of control and vehicle rollover.

## TROUBLESHOOTING

POSSIBLE CAUSE	SOLUTION
Belt slippage from water or snow ingestion into the PVT system	Dry out the PVT (see page 165). Prevent water from entering the PVT outlet duct (see page 162). Inspect clutch seals for damage if repeated leaking occurs.
Clutch malfunction	Your POLARIS dealer can assist.
Poor engine performance	Check for fouled plugs or foreign material in gas tank or fuel lines. Your POLARIS dealer can assist.
Slippage from failure to warm up belt	Always warm up the belt by operating below 30 MPH (48 km/h) for one mile (1.5 km) and for 5 miles (8 km) or more when temperature is below freezing.
Wrong or missing belt	Install the recommended belt.
Improper break-in	Always break in a new belt and/or clutch. See page 79.
Failed belt	Remove the belt and clean away any debris from the clutch box, clutch duct and engine compartment. Install a new belt. <b>WARNING!</b> Failure to remove ALL debris when replacing the belt could result in vehicle damage and severe injury or death. See the Belt Replacement / Debris Removal section for details.

**ENGINE DOESN'T TURN OVER**

<b>POSSIBLE CAUSE</b>	<b>SOLUTION</b>
Low battery voltage	Recharge the battery to 12.8 VDC
Loose battery connections	Check all connections and tighten
Loose solenoid connections	Check all connections and tighten
Loose electronic control box connections	Inspect, clean, reinstall connectors; blow on EFI fuse to remove impurities
Mechanical failure	Your POLARIS dealer or other qualified person can assist.

**ENGINE TURNS OVER, FAILS TO START**

<b>POSSIBLE CAUSE</b>	<b>SOLUTION</b>
Out of fuel	Refuel
Clogged fuel filter	Your POLARIS dealer or other qualified person can assist.
Water is present in fuel	Drain the fuel system and refuel
Old or non-recommended fuel	Replace with fresh recommended fuel
Fouled or defective spark plugs	Inspect plugs and replace if necessary
No spark to spark plug	Inspect plugs and replace if necessary
Water or fuel in crankcase	Your POLARIS dealer or other qualified person can assist.
Low battery voltage	Recharge the battery to 12.8 VDC
Loose ignition connections	Check all connections and tighten
Mechanical failure	Your POLARIS dealer or other qualified person can assist.

## TROUBLESHOOTING

---

### ENGINE BACKFIRES

POSSIBLE CAUSE	SOLUTION
Out of fuel	Refuel
Weak spark from spark plug	Inspect, clean and/or replace spark plugs
Incorrect spark plug gap or heat range	Set gap to specs or replace plugs
Old or non-recommended fuel	Replace with fresh recommended fuel
Incorrectly installed spark plug wires	Your POLARIS dealer or other qualified person can assist.
Incorrect ignition timing	Your POLARIS dealer or other qualified person can assist.
Loose ignition connections	Check all connections and tighten
Water present in fuel	Replace with fresh recommended fuel
Exhaust leak	Check all connections
Mechanical failure	Your POLARIS dealer or other qualified person can assist.

### ENGINE PINGS OR KNOCKS

POSSIBLE CAUSE	SOLUTION
Poor quality or low octane fuel	Replace with recommended fuel
Incorrect ignition timing	Your POLARIS dealer or other qualified person can assist.
Incorrect spark plug gap or heat range	Set gap to specs or replace plugs



## ENGINE RUNS IRREGULARLY, STALLS OR MISFIRES

POSSIBLE CAUSE	SOLUTION
Loose, missing or kinked boost reference lines	Replace boost reference lines
Loose or missing intake system sensor connections	Inspect connections, tighten or replace as needed
Fouled or defective spark plugs	Inspect, clean and/or replace spark plugs
Worn or defective spark plug wires	Your POLARIS dealer can assist.
Incorrect spark plug gap or heat range	Set gap to specs or replace plugs
Loose ignition connections	Check all connections and tighten
Water present in fuel	Replace with new fuel
Low battery voltage	Recharge battery to 12.8 VDC
Kinked or plugged fuel tank vent line or filter	Inspect and replace
Incorrect fuel	Replace with recommended fuel
Clogged air filter	Inspect and replace
Clogged intake pre-filter	Inspect and clean (with soapy water) or replace
Other mechanical failure	Your POLARIS dealer can assist.
Possible Lean Fuel Cause	Solution
Low or contaminated fuel	Add or change fuel, clean the fuel system
Low octane fuel	Replace with recommended fuel
Clogged fuel filter	Your POLARIS dealer can assist.

## TROUBLESHOOTING

Low fuel pressure	Your POLARIS dealer can assist.
Loose, missing, torn or kinked boost reference line from manifold to fuel pressure regulator or blow-off valve	Replace boost reference line

## ENGINE STOPS OR LOSES POWER

POSSIBLE CAUSE	SOLUTION
Out of fuel	Refuel
Kinked or plugged fuel tank vent line or filter	Inspect and replace
Water is present in fuel	Replace with new fuel
Fouled or defective spark plugs	Inspect, clean and/or replace spark plug
Worn or defective spark plug wires	Your POLARIS dealer can assist.
Incorrect spark plug gap or heat range	Set gap to specs or replace plug
Loose ignition connections	Check all connections and tighten
Low battery voltage	Recharge the battery to 12.8 VDC
Incorrect fuel	Replace with fresh recommended fuel
Clogged air filter	Inspect and replace
Clogged intake pre-filter	Inspect and clean (with soapy water) or replace
Other mechanical failure	Your POLARIS dealer can assist.
Overheated engine	Clean radiator screen and core, clean engine exterior, check coolant level. Your POLARIS dealer can assist.
Loose, missing, torn or kinked boost reference line from manifold to fuel pressure regulator or blow-off valve	Replace boost reference line
Loose, missing, torn or kinked boost reference line from turbo compressor to boost control valve	Replace boost reference line

## TROUBLESHOOTING

<b>POSSIBLE CAUSE</b>	<b>SOLUTION</b>
Loose intake system connections	Inspect connections, tighten or replace as needed
Worn or defective wastegate actuation system	Your POLARIS dealer can assist.
Overheated intake air system	Inspect intercooler water lines for leaks or kinks, repair or replace as needed



## WARRANTY

### LIMITED WARRANTY

POLARIS Industries Inc., 2100 Highway 55, Medina, MN 55340 (POLARIS) gives a SIX MONTH LIMITED WARRANTY on all components of your POLARIS vehicle against defects in material or workmanship. POLARIS further warrants that the spark arrester in this product will meet the efficiency requirements of USFS standard 5100-1C for at least 1000 hours when subjected to normal use and when maintenance and installation are in accordance with POLARIS recommendations.

This warranty covers parts and labor charges for repair or replacement of defective parts and begins on the date of purchase by the original retail purchaser. This warranty is transferable to another owner during the warranty period through a POLARIS dealer, but any such transfer will not extend the original term of the warranty. The duration of this warranty may vary by international region based upon local laws and regulations.

## REGISTRATION

At the time of sale, the Warranty Registration Form must be completed by your dealer and submitted to POLARIS within ten days of purchase. Upon receipt of this registration, POLARIS will record the registration for warranty. No verification of registration will be sent to the purchaser as the copy of the Warranty Registration Form will be your proof of warranty coverage. If you have not signed the original registration and received the customer copy, please contact your dealer immediately. **NO WARRANTY COVERAGE WILL BE ALLOWED UNLESS YOUR VEHICLE IS REGISTERED WITH POLARIS.** Initial dealer preparation and set-up of your vehicle is very important in ensuring trouble-free operation. Purchasing a machine in the crate or without proper dealer set-up will void your warranty coverage.

### WARRANTY COVERAGE AND EXCLUSIONS

#### LIMITATIONS OF WARRANTIES AND REMEDIES

This POLARIS limited warranty excludes any failures that are not caused by a defect in material or workmanship. THIS WARRANTY DOES NOT COVER CLAIMS OF DEFECTIVE DESIGN. This warranty also does not cover acts of God, accidental damage, normal wear and tear, abuse or improper handling. This warranty also does not cover any vehicle, component, or part that has been altered structurally, modified, neglected, improperly maintained or used for racing, competition or purposes other than for which it was designed.

This warranty excludes damages or failures resulting from improper lubrication; improper engine timing; improper fuel; surface imperfections caused by external stress, heat, cold or contamination; operator error or abuse; improper component alignment, tension, adjustment or altitude compensation; snow, water, dirt or other foreign substance ingestion/contamination; improper maintenance; modified components; use of aftermarket or unapproved components, accessories, or attachments; unauthorized repairs; or repairs made after the warranty period expires or by an unauthorized repair center.

This warranty excludes damages or failures caused by abuse, accident, fire, or any other cause other than a defect in materials or workmanship and provides no coverage for consumable components, general wear items, or any parts exposed to friction surfaces, stresses, environmental conditions and/or contamination for which they were not designed or not intended, including but not limited to the following items:

- Wheels and tires
- Suspension components
- Brake components
- Seat components
- Clutches and components
- Steering components
- Batteries
- Light bulbs/Sealed beam lamps
- Filters
- Lubricants
- Bushings
- Finished and unfinished surfaces
- Carburetor/Throttle body components
- Engine components
- Drive belts
- Hydraulic components and fluids
- Circuit breakers/Fuses
- Electronic components
- Spark plugs
- Sealants
- Coolants
- Bearings

## LUBRICANTS AND FLUIDS

1. Mixing oil brands or using non-recommended oil may cause engine damage. We recommend the use of POLARIS engine oil.
2. Damage or failure resulting from the use of non-recommended lubricants or fluids is not covered by this warranty.

This warranty provides no coverage for personal loss or expense, including mileage, transportation costs, hotels, meals, shipping or handling fees, product pick-up or delivery, replacement rentals, loss of product use, loss of profits, or loss of vacation or personal time.

THE EXCLUSIVE REMEDY FOR BREACH OF THIS WARRANTY SHALL BE, AT POLARIS' OPTION, REPAIR OR REPLACEMENT OF ANY DEFECTIVE MATERIALS, COMPONENTS, OR PRODUCTS. THE REMEDIES SET FORTH IN THIS WARRANTY ARE THE ONLY REMEDIES AVAILABLE TO ANY PERSON FOR BREACH OF THIS WARRANTY. POLARIS SHALL HAVE NO LIABILITY TO ANY PERSON FOR INCIDENTAL, CONSEQUENTIAL OR SPECIAL DAMAGES OF ANY DESCRIPTION, WHETHER ARISING OUT OF EXPRESS OR IMPLIED WARRANTY OR ANY OTHER CONTRACT, NEGLIGENCE, OR OTHER TORT OR OTHERWISE. THIS EXCLUSION OF CONSEQUENTIAL, INCIDENTAL, AND SPECIAL DAMAGES IS INDEPENDENT FROM AND SHALL SURVIVE ANY FINDING THAT THE EXCLUSIVE REMEDY FAILED OF ITS ESSENTIAL PURPOSE.

THE IMPLIED WARRANTY OF FITNESS FOR A PARTICULAR PURPOSE IS EXCLUDED FROM THIS LIMITED WARRANTY. ALL OTHER IMPLIED WARRANTIES (INCLUDING BUT NOT LIMITED TO THE IMPLIED WARRANTY OF MERCHANTABILITY) ARE LIMITED IN DURATION TO THE ABOVE SIX MONTH WARRANTY PERIOD. POLARIS DISCLAIMS ALL EXPRESS WARRANTIES NOT STATED IN THIS WARRANTY. SOME STATES DO NOT PERMIT THE EXCLUSION OR LIMITATION OF INCIDENTAL OR CONSEQUENTIAL DAMAGES OR ALLOW LIMITATIONS ON THE DURATION OF IMPLIED WARRANTIES, SO THE ABOVE LIMITATIONS MAY NOT APPLY TO YOU IF INCONSISTENT WITH CONTROLLING STATE LAW.

### HOW TO OBTAIN WARRANTY SERVICE

If your vehicle requires warranty service, you must take it to a POLARIS Servicing Dealer. When requesting warranty service you must present your copy of the Warranty Registration Form to the dealer. (THE COST OF TRANSPORTATION TO AND FROM THE DEALER IS YOUR RESPONSIBILITY.) POLARIS suggests that you use your original selling dealer; however, you may use any POLARIS Servicing Dealer to perform warranty service.

***In the Country where your product was purchased:***

Warranty or Service Bulletin repairs must be done by an authorized POLARIS dealer. If you move or are traveling within the country where your product was purchased, Warranty and Service Bulletin repairs may be requested from any authorized POLARIS dealer that sells the same line as your product.

***Outside the Country where your product was purchased:***

If you are traveling temporarily outside the country where your product was purchased, you should take your product to an authorized POLARIS dealer. You must show the dealer photo identification from the country of the selling dealer's authorized location as proof of residence. Upon residence verification, the servicing dealer will be authorized to perform the warranty repair.

***If you move:***

If you move to another country, be sure to contact POLARIS Customer Assistance and the customs department of the destination country before you move. Product importation rules vary considerably from country to country. You may be required to present documentation of your move to POLARIS in order to continue your warranty coverage. You may also be required to obtain documentation from POLARIS in order to register your product in your new country. You should warranty register your product at a local POLARIS dealer in your new country immediately after you move to continue your warranty coverage and to ensure that you receive information and notices regarding your vehicle.

***If you purchase from a private party:***

If you purchase a POLARIS product from a private party, to be kept and used outside of the country in which the product was originally purchased, all warranty coverage will be denied. You must nonetheless register your product under your name and address with a local POLARIS dealer in your country to ensure that you receive safety information and notices regarding your product.



## NOTICE

If your product is registered outside of the country where it was purchased and you have not followed the procedure set above, your product will no longer be eligible for warranty or service bulletin coverage of any kind, other than safety bulletins. Products registered to government officials or military personnel on assignment outside of the country where the product was purchased will continue to be covered by the Limited Warranty.

Please work with your dealer to resolve any warranty issues. Dealership contacts can be found via this website, if needed:

**[www.polaris.com/en-us/contact](http://www.polaris.com/en-us/contact)**

Should your dealer require any additional assistance, they will contact the appropriate person at POLARIS.

This warranty gives you specific legal rights, and you may also have other rights which vary from state to state or in different countries. If any of the above terms are void because of federal, state, local law, all other warranty terms will remain in effect.

***For questions call POLARIS Customer Assistance:***

United States & Canada: 1-800-POLARIS (1-800-765-2747)

French: 1-800-268-6334

## WARRANTY

---

### **U.S.A. EPA EMISSIONS LIMITED WARRANTY**

This emissions limited warranty is in addition to the POLARIS standard limited warranty for your vehicle. POLARIS Industries Inc. warrants that at the time it is first purchased, this emissions-certified vehicle is designed, built and equipped so it conforms with applicable U.S. Environmental Protection Agency emission regulations. POLARIS warrants that the vehicle is free from defects in materials and workmanship that would cause it to fail to meet these regulations.

The warranty period for off road vehicles 100cc or greater emissions-certified vehicles starts on the date of purchase by original retail purchaser and continues for a period of 500 hours of engine operation, 5000 kilometers (3100 miles) of vehicle travel, or 30 calendar months from the date of purchase, whichever comes first. The warranty period for ATVs less than 100cc emissions-certified vehicles starts on the date of purchase by original retail purchaser and continues for a period of 250 hours of engine operation, 2500 kilometers (1550 miles) of vehicle travel, or 30 calendar months from the date of purchase, whichever comes first. This EPA emissions warranty period is extended for at least as long as the standard factory warranty that Polaris provides on the vehicle as a whole. The EPA emissions warranty period does not further extend if you purchase additional warranty coverage in the form of a service contract or other paid warranty extension, but emission-related parts may be covered subject to the terms of any such paid service contract or paid warranty extension.

This emissions limited warranty covers components whose failure increases the vehicle's regulated emissions, and it covers components of systems whose only purpose is to control emissions. Repairing or replacing other components not covered by this warranty is the responsibility of the vehicle owner. This emissions limited warranty does not cover components whose failure does not increase the vehicle's regulated emissions.

For exhaust emissions, emission-related components include any engine parts related to the following systems:

- Air-induction system
- Fuel System
- Ignition system
- Exhaust gas recirculation systems

The following parts are also considered emission-related components for exhaust emissions:

- After treatment devices
- Crankcase ventilation valves
- Sensors
- Electronic control units

The following parts are considered emission-related components for evaporative emissions:

- Fuel Tank
- Fuel Cap
- Fuel Line
- Fuel Line Fittings
- Clamps\*
- Pressure Relief Valves\*
- Control Valves\*
- Control Solenoids\*
- Electronic Controls
- Vacuum Control Diaphragms\*
- Control Cables\*
- Control Linkages\*
- Purge Valves
- Vapor Hoses
- Liquid/Vapor Separator
- Carbon Canister
- Canister Mounting Brackets
- Carburetor Purge Port Connector

\*As related to the evaporative emission control system.

Emission-related components also include any other part whose only purpose is to reduce emissions or whose failure will increase emissions without significantly degrading engine/equipment performance. The exclusive remedy for breach of this limited warranty shall be, at the exclusive option of POLARIS, repair or replacement of any defective materials, components or products. THE REMEDIES SET FORTH IN THIS LIMITED WARRANTY ARE THE ONLY REMEDIES AVAILABLE TO ANY PERSON FOR BREACH OF THIS WARRANTY. POLARIS SHALL HAVE NO LIABILITY TO ANY PERSON FOR INCIDENTAL, CONSEQUENTIAL OR SPECIAL DAMAGES OF ANY DESCRIPTION, WHETHER ARISING OUT OF EXPRESS OR IMPLIED WARRANTY OR ANY OTHER CONTRACT, NEGLIGENCE OR OTHER TORT OR OTHERWISE. THIS EXCLUSION OF CONSEQUENTIAL, INCIDENTAL, AND SPECIAL DAMAGES IS INDEPENDENT FROM AND SHALL SURVIVE ANY FINDING THAT THE EXCLUSIVE REMEDY FAILED OF ITS ESSENTIAL PURPOSE.

ALL IMPLIED WARRANTIES (INCLUDING BUT NOT LIMITED TO ANY IMPLIED WARRANTIES OF MERCHANTABILITY AND FITNESS FOR A PARTICULAR PURPOSE) ARE LIMITED IN DURATION TO THE WARRANTY PERIOD DESCRIBED HEREIN. POLARIS DISCLAIMS ALL EXPRESS WARRANTIES NOT STATED IN THIS WARRANTY. Some states do not allow limitations on how long an implied warranty lasts, so the above limitation may not apply if it is inconsistent with the controlling state law.

This limited warranty excludes failures not caused by a defect in material or workmanship. This limited warranty does not cover damage due to accidents, abuse or improper handling, maintenance or use. This limited warranty also does not cover any engine that has been structurally altered, or when the vehicle has been used in racing competition. This limited warranty also does not cover physical damage, corrosion or defects caused by fire, explosions or other similar causes beyond the control of POLARIS.

## WARRANTY

---

Owners are responsible for performing the scheduled maintenance identified in the owner's manual. POLARIS may deny warranty claims for failures that have been caused by the owner's or operator's improper maintenance or use, by accidents for which POLARIS has no responsibility, or by acts of God.

Any qualified repair shop or person may maintain, replace, or repair the emission control devices or systems on your vehicle. An authorized POLARIS dealer can perform any service that may be necessary for your vehicle. POLARIS also recommends POLARIS parts, however equivalent parts may be used for such service. It is a potential violation of the Clean Air Act if a part supplied by an aftermarket parts manufacturer reduces the effectiveness of the vehicle's emission controls. Tampering with emission controls is prohibited by federal law.

## **CALIFORNIA RESIDENTS**

Certain POLARIS Off-Road Vehicles are available in 49-state and 50-state versions. Only the 50-state models are certified for sale in California. The 50-state models available for sale in California are identified by the letter "B" in the ninth position of the model number (e.g., R16RTE87B). The POLARIS 50-state models are designed and built with features such as a reduced cargo box capacity. Any modifications to these features may be a violation of the applicable California regulations and may void this limited emissions warranty offered by the manufacturer.

The California evaporative emissions control system limited warranty statement below applies to your Off Highway Recreational Vehicle in California if the vehicle is equipped with an evaporative emission control system and is labeled with a Vehicle Evaporative Emissions Control Information label indicating that the vehicle conforms to California evaporative emissions regulations applicable to new off-road sport vehicles, all-terrain vehicles, or off-road utility vehicles. These vehicles are referred to as "OHRV-EVAP" below.

### **CALIFORNIA EMISSION CONTROL WARRANTY STATEMENT YOUR WARRANTY RIGHTS AND OBLIGATIONS**

The California Air Resources Board and Polaris Industries Inc. is pleased to explain the emission control system warranty on your model year 2018 and newer Off Highway Recreational Vehicle. In California, new off-highway recreational vehicles must be designed, built and equipped to meet the State's stringent anti-smog standards. Polaris must warrant the emission control system on your OHRV-EVAP for the periods of time listed below provided there has been no abuse, neglect or improper maintenance of your OHRV-EVAP.

Your emission control system may include parts such as the carburetor or fuel injection system, fuel tank, fuel hoses, carbon canister, engine computer and Evaporative Emissions Control System parts listed in the U.S.A. EPA Emissions Limited Warranty. Also included may be hoses, belts, connectors and other emission-related assemblies. Where a warrantable condition exists, Polaris will repair your OHRV-EVAP at no cost to you including diagnosis, parts and labor.

#### **MANUFACTURER'S WARRANTY COVERAGE:**

For model year 2018 and newer OHRV-EVAP models.

For 30 months, or 2500 miles, or 250 hours, whichever comes first, except for evaporative components over the OHRV high-priced warranty value, which is covered for 60 months, or 5000 miles, or 500 hours, whichever comes first.

If any emission-related part on your OHRV-EVAP is defective, the part will be repaired or replaced by Polaris.

## WARRANTY

---

### OWNER'S WARRANTY RESPONSIBILITIES:

As the OHRV-EVAP owner, you are responsible for the performance of the required maintenance listed in your owner's manual. Polaris recommends that you retain all receipts covering maintenance on your OHRV-EVAP, but Polaris cannot deny warranty solely for the lack of receipts or for your failure to ensure the performance of a scheduled maintenance.

As an owner you are responsible for presenting your OHRV-EVAP to a Polaris dealer as soon as a problem exists. The warranty repairs should be completed in a reasonable amount of time, not to exceed 30 days.

As an OHRV-EVAP owner, you should also be aware that Polaris may deny you warranty coverage if your OHRV-EVAP or a part has failed due to abuse, neglect, improper maintenance or unapproved modifications.

### ADD-ON OR MODIFIED PARTS

An add-on or modified part must be compliant with applicable CARB emission control standards. A violation of this requirement is punishable by civil and/or criminal punishment.

If you have any questions regarding your warranty rights and responsibilities, you should contact Polaris Customer Assistance at 1-800-POLARIS (1-800-765-2747) or the California Air Resources Board at 9528 Telstar Avenue, El Monte, CA 91731.

United States & Canada: 1-800-POLARIS (1-800-765-2747)

French: 1-800-268-6334

## MAINTENANCE LOG

### MAINTENANCE LOG

Use the following chart to record periodic maintenance.

DATE	MILES (KM) OR HOURS	TECHNICIAN	SERVICE PERFORMED / COMMENTS

## SAFETY SYMBOLS AND SIGNAL WORDS

---

- Improper service or maintenance of this PVT system can result in vehicle damage, SEVERE INJURY or DEATH.
- Always look for and remove debris inside and around the clutch and vent system when replacing the belt.
- Read owner's manual or see authorized dealer.

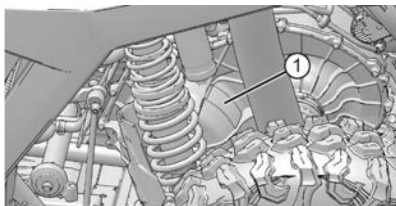

① Belt Debris Warning



---

3-Point Seat Belt .....	44
6-Point Seat Belt .....	44

## A

Adding or Changing Coolant .....	161
Air Box Caution .....	15
Air Filter.....	167
All Wheel Drive (AWD) Switch .....	34
All Wheel Drive (AWD) System .....	50
Audio Controls (if equipped).....	37
Auxiliary Outlets .....	34
Axle and Wheel Nut Torque Specifications.....	180

## B

Battery .....	185
Battery Installation .....	185
Battery Maintenance and Charging .....	186
Battery Removal.....	185
Belt Debris Warning .....	14, 222
Belt Replacement / Debris Removal .....	163
Brake and Throttle Pedals .....	49
Brake Fluid.....	173
Brake Inspection .....	172
Brakes .....	171
Braking .....	85

## C

Cab Doors .....	22, 46
California Residents .....	219
Carrying Multiple Passengers (2-Seat) .....	22
Carrying Multiple Passengers (4-Seat) .....	22
Check Engine Indicator .....	60
Component Locations.....	31
Coolant Adding or Changing .....	161
Cooling System.....	158

Crankcase Emission Control System .....	113
Crossing Hillsides .....	25

## D

Demand Drive Fluid Change .....	151
Demand Drive Fluid Check .....	151
Demand Drive Unit (Front Gearcase) .....	150
Descending Hills Improperly .....	25
Diagnostic Display Code Definitions .....	61
Display Units, Standard/Metric .....	58
Drive Belt Wear / Burn .....	203
Drive Responsibly Warning .....	13
Driving Downhill .....	91
Driving in Reverse .....	94
Driving on a Sidehill (Sidehilling) ...	90
Driving on Slippery Surfaces .....	88
Driving Over Obstacles .....	93
Driving Through Water.....	92
Driving Uphill .....	89
Driving With Passengers .....	87

## E

Electromagnetic Interference .....	113
Electronic Power Steering (EPS)...	35
Engaging AWD .....	50
Engine Backfires .....	206
Engine Doesn't Turn Over .....	205
Engine Pings or Knocks .....	206
Engine Runs Irregularly, Stalls or Misfires .....	207
Engine Stops or Loses Power ...	208
Engine Turns Over, Fails to Start.....	205
Equipment Modifications .....	29
Error Codes, Engine.....	60
Exhaust Emission Control System .....	113
Exposure to Exhaust .....	28

---

**F**

Factory Default Preload Settings .....	177
Failure to Inspect Before Operating .....	21
Fluid Change .....	149
Fluid Check .....	148
Front / Rear Shock Compression Adjustment .....	178
Front / Rear Spring Preload Adjustment .....	176
Fuel / Load / Passenger / Tire Pressure Alerts .....	19
Fuel Level .....	43
Fuel Recommendations .....	42
Fuel Transport Warning .....	13
Fuse / Relay Center .....	155

**G**

Gear Selector .....	48
Gearcase Specification Chart .....	152
General Alert .....	17

**H**

Hauling Cargo .....	96
Headlight Beam Adjustment .....	183
Headlight Replacement .....	182
Headlight Switch .....	34
Hot Exhaust Systems .....	28
How To Obtain Warranty Service .....	214

**I**

Ignition Switch .....	33
Improper Cargo Loading .....	28
Improper Hill Climbing .....	25
Improper Tire Maintenance .....	26
Indicator Lamps .....	52
Instrument Cluster .....	51
Intake Alert .....	18
Intake Pre-Filters .....	166

**J**

Jumps and Stunts .....	24
------------------------	----

**K**

Know Your Riding Area / Tread Lightly .....	85
---	----

**L**

Lights .....	182
Limited Warranty .....	211
Load / Passenger / Tire Pressure Warning .....	16
Lubrication Recommendations ..	141

**M**

Maintenance Chart Tables .....	116
Maintenance Log .....	221
Metric Display .....	58
Mode Button .....	52

**N**

New Operator Driving Procedures .....	85
Noise Emission Control System ..	113
Notice .....	215

**O**

Oil and Filter Change .....	145
Oil Check .....	144
Oil Recommendations .....	143
Operating on Pavement .....	23
with a Load on the Vehicle .....	23
Operating a Damaged Vehicle .....	28
Operating at Excessive Speeds ..	24
Operating Improperly in Reverse ..	26
Operating in Cold Weather .....	27
Operating in Unfamiliar Terrain ..	26

Operating on Frozen Bodies of Water .....	27
Operating on Public Roads .....	24
Operating Over Obstacles .....	27
Operating Through Water .....	27
Operation on Public Lands in the U.S.A.....	113
Operator Restrictions/ Age Restrictions .....	20
Output Gear Ratios .....	199
Owner's Manual Alert .....	17

## P

Parking on an Incline .....	95
Parking the Vehicle .....	85
Passenger Hand Hold .....	42
Passengers in the Cargo Box .....	23
Periodic Maintenance Chart .....	115
Polaris Products .....	201
POLARIS Variable Transmission (PVT) System .....	162
Polishing the Vehicle .....	189
Pre-Ride Inspection .....	81
Programmable Service Interval .....	59
Proper Use Warning .....	12
Protective Apparel .....	21
PVT Drying .....	165

## R

Radiator Coolant Level / Changing Coolant .....	158
Radiators and Cooling Fan .....	161
Rear Cargo Box .....	46
Rear Seat Removal.....	39
Refueling .....	29
Registration.....	211
Rider Information Center .....	54
Riders Warning .....	13
Rollover Protective Structure (ROPS).....	47

## S

Safe Operation Practices .....	83
Safe Riding Gear.....	10
Safety Labels and Locations .....	12
Safety Symbols.....	4
Safety Training.....	9
Safety Warnings.....	20
Safety, Winch Maintenance.....	111
Seat Adjustments .....	40
Seat Belt Inspection .....	44
Seat Belt Warning.....	14
Seat Belts .....	21, 43
Seat Removal.....	38
Seats .....	38
Service Access Panels .....	45
Shock Adjustment Recommendations .....	174
Shock Loading the Winch .....	110
Signal Words.....	4
Skidding or Sliding .....	26
Spark Arrester .....	169
Spark Plug Condition.....	154
Spark Plug Gap / Torque .....	153
Spark Plug Removal and Replacement .....	153
Specifications .....	195
Specifications (4-Seat).....	197
Stalling While Climbing a Hill.....	25
Standard Steering Wheel (if equipped).....	32
Starting the Engine .....	84
Steering Wheel Inspection.....	184
Stopping the Engine.....	84
Storage Tips.....	190
Suspension Controls (if equipped).....	35
Switches Mode Button.....	52

## T

Tachometer .....	52
Taillight / Brake Light Replacement .....	182
Tire Rotation.....	180
Tires .....	179

---

Towing .....	98
Towing a RZR .....	99
Trail Etiquette .....	86
Transmission (Main Gearcase) ...	148
Transporting the Vehicle.....	193
Turning Improperly.....	24

## U

U.S.A. EPA Emissions Limited	
Warranty .....	216
Unauthorized Use of the Vehicle ...	29
Using Alcohol or Drugs .....	21

## V

Vehicle Break-in Period.....	79
Vehicle Identification Numbers .....	8
Vehicle Immersion .....	184

## W

Warning Symbols .....	4
Warranty Coverage and	
Exclusions.....	212
Washing the Vehicle.....	188
Wheel Installation .....	181
Wheel Removal.....	180
Winch Cable Care .....	109
Winch Maintenance and	
Service Safety .....	111
Winch Operation .....	104
Winch Safety Precautions .....	101
Winch Shock Loading.....	110





**FOR YOUR NEAREST POLARIS DEALER,  
CALL 1-800-POLARIS (765-2747)  
OR VISIT [WWW.POLARIS.COM](http://WWW.POLARIS.COM)**

**POLARIS INDUSTRIES INC.  
2100 HIGHWAY 55  
MEDINA, MN 55340**

**PART NO. 9929980 REV 01  
PRINTED IN USA**

