

## Engine Oil Level

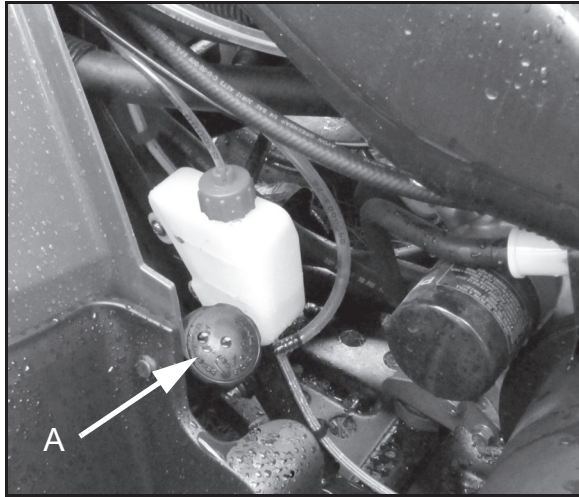

The oil tank is located on the left side of the vehicle. To check the oil level:

1. Set machine on a level surface.
2. Clean the area around the dip stick.
3. Start and run engine for 20-30 seconds. This will return oil to its true level in the oil tank.
4. Stop engine, remove dipstick (A) and wipe dry with a clean cloth.
5. Reinstall dipstick, screw the dipstick into place.

**NOTE:** The dipstick must be screwed completely in to ensure accurate measurement.

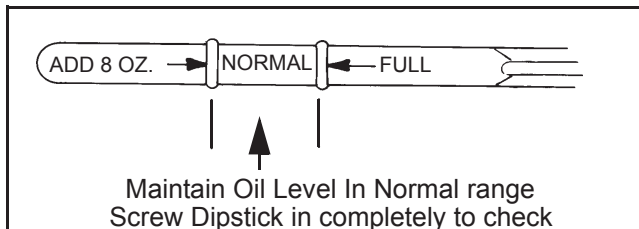

6. Remove dipstick and check to see that the oil level is in the normal range. The oil should be between the top line and the bottom line on the dipstick. Add oil as indicated by the level on the dipstick. Do not overfill.

**NOTE:** Rising oil level between checks in cool weather driving, can indicate moisture collecting in the oil reservoir. If the oil level is over the full mark, change the oil.

## Oil and Filter Change

**Oil Filter Torque:**  
Turn by hand until filter gasket contacts sealing surface, then turn an additional 1/2 turn

**Oil Filter Wrench:**  
(PV-43527)

**Oil Tank Screen Fitting Torque:**  
25 ft-lb (34Nm)

**Recommended Engine Oil:**

**Polaris PS 4 PLUS  
Synthetic, 2W-50**



**Personal injury can occur when handling used oil. Hot oil can cause burns or skin damage.**

**NOTICE:** Care must be taken to ensure that the fluids are contained. Be prepared to collect the fluid with suitable containers before opening any compartment or disassembly of any component containing fluids.

1. Place vehicle on a level surface.
2. Clean area around drain plug (A) at bottom of oil tank.
3. Run engine two to three minutes until the engine is warm.
4. After two or three minutes stop the engine.
5. Place a drain pan beneath oil tank and remove the drain plug (A). **CAUTION:** Oil may be hot. Do not allow hot oil to come into contact with skin as serious burns may result.

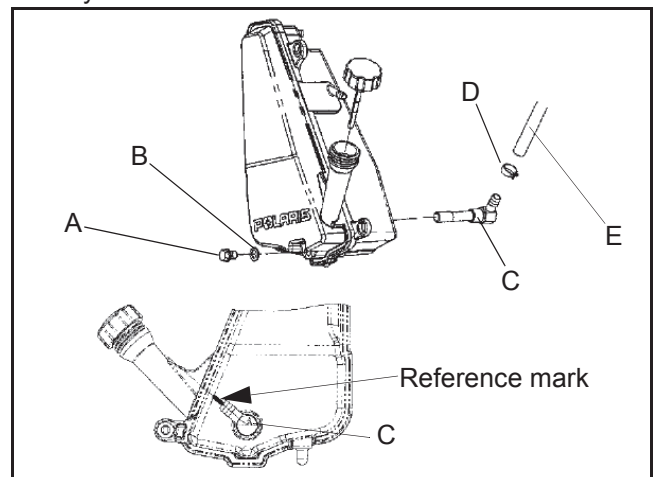

6. Allow oil to drain completely.
7. Replace sealing washer (B) on drain plug (A).

**NOTE: The sealing surfaces on the drain plug and the oil tank should be clean and free of burrs, nicks or scratches.**

8. Reinstall the drain plug (A) and torque it to specification.

 = T
<b>Oil Tank Drain Plug Torque:</b> <b>14 ft. lbs. (19 Nm)</b>
<b>Crankcase Drain Plug Torque:</b> <b>14 ft. lbs. (19 Nm)</b>

9. Loosen clamp (D).
10. Remove oil hose (E) from screen fitting (C) on bottom of oil tank.
11. Remove screen fitting (C) and clean the screen.
12. Apply Loctite™ thread sealant 505 or an equivalent pipe thread sealant or PTFE sealant tape to clean, oil free threads of fitting (C).
13. Install screen fitting (C) and rotate a minimum of 2 1/2 turns (clockwise) into the tank threads. Then rotate the screen fitting clockwise until the nipple of the screen fitting aligns with the reference marking on the tank.

 <b>CAUTION</b>
Maximum torque for the screen fitting is 25 ft-lb (34Nm), do not over tighten.

**NOTE: Maximum torque for the screen fitting is 25 ft-lb (34Nm), do not over tighten.**

14. Install oil hose (E) on fitting (C) and re-install clamp (D).

15. Place shop towels beneath oil filter. Use Oil Filter Wrench (PV-43527), turn filter counterclockwise to remove.

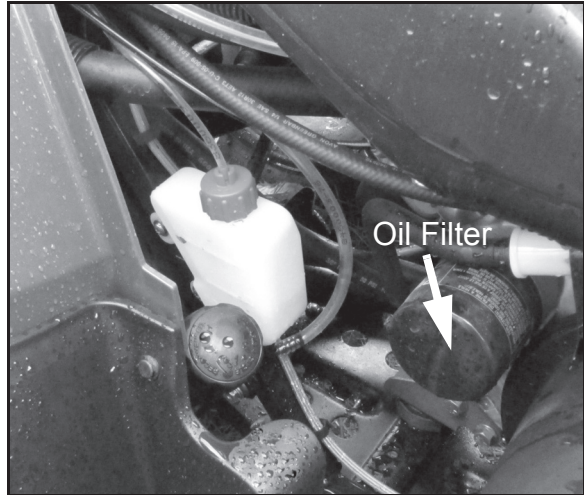

16. Using a clean dry cloth, clean filter sealing surface on the crankcase.
17. Lubricate the o-ring on new filter with a thin film of engine oil. Check to make sure the O-ring is in good condition.
18. Install the new filter and turn it by hand until the filter gasket contacts the sealing surface, then turn an additional 1/2 of a turn.
19. Approximately 1 cup of engine oil will remain in the crankcase. To drain, remove drain plug found on lower right side of crankcase.

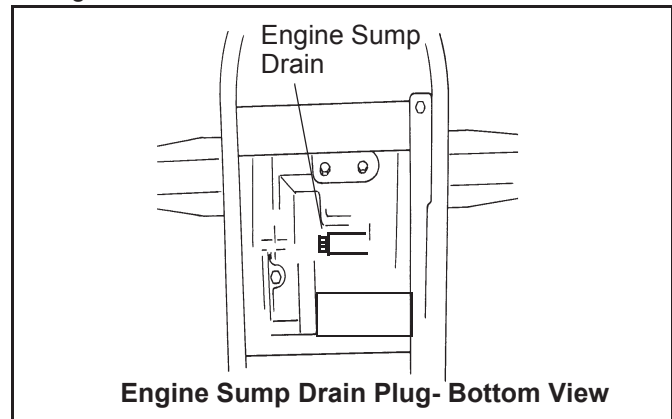

**NOTE: The sealing surfaces on the drain plug and crankcase should be clean and free of burrs, nicks or scratches.**

20. Reinstall drain plug and torque to specification.
21. Remove dipstick and fill tank with 2 quarts (1.9 L) of Polaris Premium 4 Synthetic Oil.
22. Place gear selector in Park and set parking brake.

**NOTE: Clamp or pinch off the vent line 2" from the oil tank as shown in the Oil Pump Priming Procedure.**

23. Re-check the oil level on the dipstick and add oil as necessary to bring the level to the upper mark on the dipstick.
24. Dispose of used filter and oil properly.

### Oil Pump Priming Procedure

**NOTE: This priming procedure must be performed whenever the oil hose connection between the oil tank and pump inlet has been disconnected.**

1. Clamp or pinch off vent line (A) approximately 2" from oil tank to avoid the end of oil tank vent fitting, and the vent line's pressure relief slit

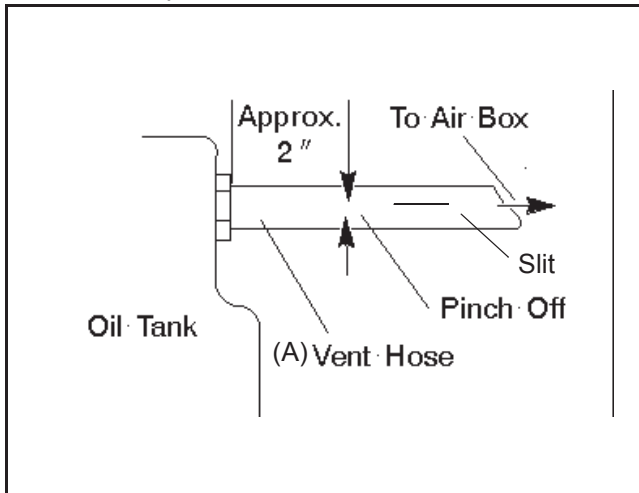

2. Run engine at IDLE for 10-15 seconds.
3. Remove the vent line clamp. The oil pump will now be properly primed and ready for field operation. **Note:** *If the system is primed properly you should hear some air release. If you do not, the system has not primed. Repeat the process if necessary.*

