

Engine Oil and Filter Change

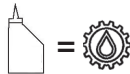

Recommended Engine Oil:

PS-4 PLUS 2W-50 Synthetic
4-Cycle Engine Oil
(PN 2876244) (Quart)

1. Place vehicle on a level surface and allow the engine to run for two to three minutes until warm. Stop engine.
2. Clean the area around drain plug at the bottom of oil tank.

WARNING

Personal injury can occur when handling used oil. Hot oil can cause burns or skin damage.

3. Place a drain pan beneath oil tank and remove drain plug.

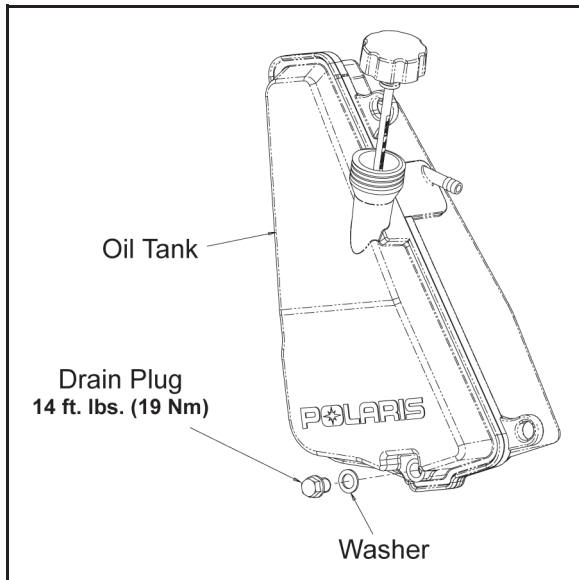

4. Allow oil to drain completely.
5. Replace sealing washer on the drain plug.

NOTE: The sealing surfaces on drain plug and oil tank should be clean and free of burrs, nicks or scratches.

6. Reinstall the drain plug and torque to **14 ft. lbs. (19 Nm)**.



Oil Tank Drain Plug: 14 ft. lbs. (19 Nm)

7. Loosen the clamp at the screen fitting.

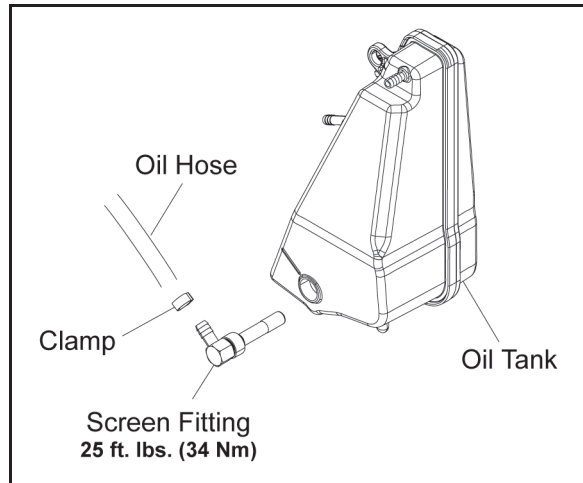

8. Remove the oil hose from the screen fitting at the bottom of the oil tank.
9. Remove screen fitting and clean the screen thoroughly.
10. Apply Loctite™ 565 Thread Sealant (PN 2871956) to the clean and oil free threads of the fitting.

11. Install screen fitting and rotate a minimum of 2 1/2 turns (clockwise) into the tank threads. Then rotate the screen fitting clockwise until the nipple of the screen fitting aligns with the marking on the tank.

NOTE: Do not overtighten screen fitting, damage to fitting / tank can occur.

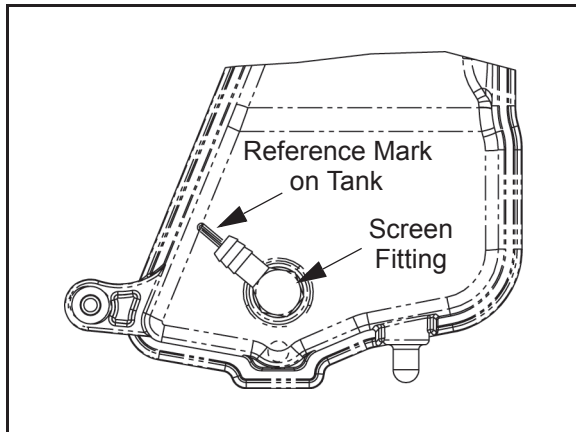

Oil Tank Screen Fitting:
25 ft. lbs. (34 Nm); See step 11

12. Install the oil hose on the screen fitting and install the clamp.
13. Place shop towels beneath oil filter. Using an Oil Filter Wrench (PV-43527), turn filter counterclockwise to remove.

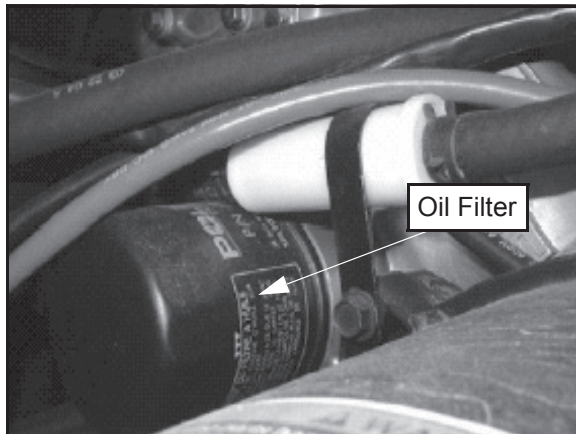

Oil Filter Wrench: PV-43527

14. Using a clean, dry cloth, clean filter sealing surface on crankcase.

15. Check to make sure the O-ring on the new oil filter is in good condition. Lubricate O-ring on new filter with a film of clean engine oil.

16. Install new oil filter and turn by hand until filter gasket contacts the sealing surface, then turn and additional 1/2 - 3/4 turn.



Oil Filter Torque:

Turn by hand until filter gasket contacts sealing surface, then turn an additional 1/2 - 3/4 turn.

17. Remove dipstick and fill oil tank with 2 quarts (1.9 l) of Polaris PS-4 PLUS 2W-50 Synthetic 4-Cycle Engine Oil (PN 2876244).
18. Place gear selector in neutral and set parking brake.
19. Prime oil pump using the "**Oil Pump Priming Procedure**". Stop the engine and inspect for leaks.
20. Re-check the oil level on the dipstick and add oil as necessary to bring the level to the upper mark on the dipstick.
21. Dispose of used oil and oil filter properly.

Oil Pump Priming Procedure

NOTE: This priming procedure must be performed whenever the oil hose connection between the oil tank and pump inlet has been disconnected.

1. Clamp or pinch off vent hose approximately 2" from oil tank to avoid the end of oil tank vent fitting, and before the vent line's pressure relief slit

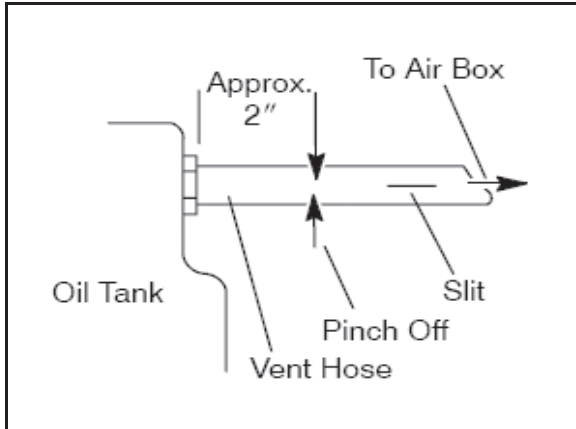

2. Run engine for 10-20 seconds.
3. Remove the clamp from the vent hose. The oil pump will now be properly primed and ready for field operation.

NOTE: If the system is primed properly you should hear some air release. If you do not, the system has not primed. Repeat the process if necessary.

