

ROPS SIDE MIRROR KIT



P/N 2889099

MISSING OR DAMAGED PARTS

Before beginning assembly, inspect the kit and its component(s) to be sure all parts and tools are accounted for and not damaged. If missing parts or parts are damaged, please contact your Selling Dealer for assistance.

If your accessory was purchased online, please contact POLARIS® customer service at **1-800-POLARIS** (US & Canada only).

APPLICATION

Verify accessory fitment at www.polaris.com.

KIT CONTENTS

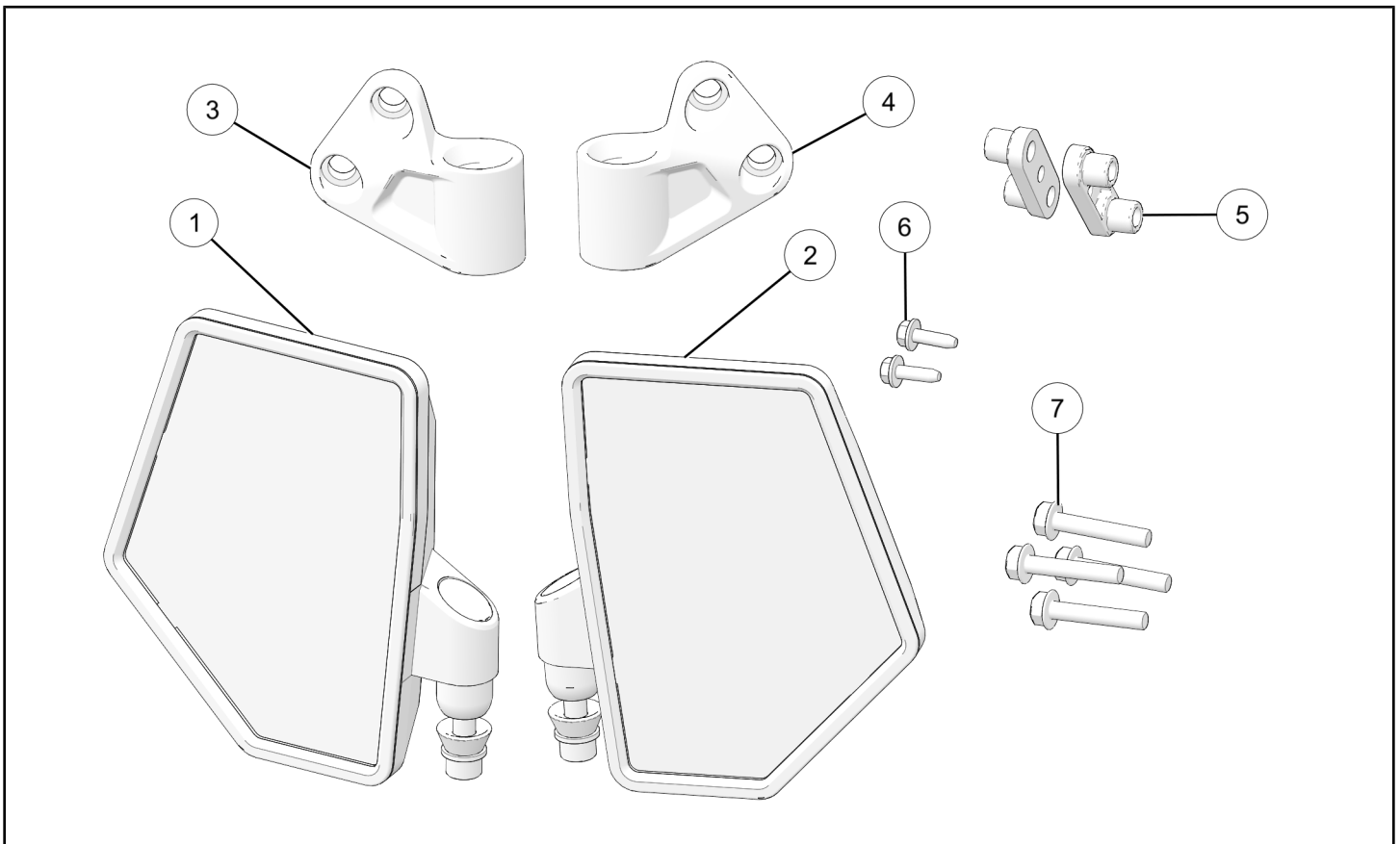

REF	QTY	PART DESCRIPTION	P/N AVAILABLE SEPARATELY	AVAILABLE SERVICE KIT
1	1	Assembly, Mirror, Left	2638917	2211698
2	1	Assembly, Mirror, Right	2638918	2211699
3	1	Mount, Mirror, Left	5459743	2209800
4	1	Mount, Mirror, Right	5459744	2209801
5	2	Bracket	5639426	2209800 (QTY 1) 2209801 (QTY 1)

REF	QTY	PART DESCRIPTION	P/N AVAILABLE SEPARATELY	AVAILABLE SERVICE KIT
6	2	Screw, M6 x 1.0 x 20 mm	7518529	2209800 (QTY 1) 2209801 (QTY 1)
7	4	Screw, Hex Flanged, M8 x 1.25 x 45 mm	7521332-45	2209800 (QTY 2) 2209801 (QTY 2)

TOOLS REQUIRED

- Safety Glasses
- Drill
- Drill Bit:
 - 5/8 Bit Size in (15.8 Bit Size mm)
- Pliers, Push Pin Rivet
- Screwdriver, Slotted
- Socket Set, Hex Bit, Metric
- Socket Set, Metric
- Torque Wrench

IMPORTANT

Your ROPS Side Mirror Kit is exclusively designed for your vehicle. Please read the installation instructions thoroughly before beginning. Installation is easier if the vehicle is clean and free of debris. For your safety, and to ensure a satisfactory installation, perform all installation steps correctly in the sequence shown.

INSTALLATION INSTRUCTIONS

VEHICLE PREPARATION

GENERAL

1. Park vehicle on a flat surface.
2. Shift vehicle into PARK.
3. Turn key to OFF position and remove key.

ACCESSORY INSTALLATION

1. Remove and keep two push-pin rivets and remove and keep A-pillar cover.

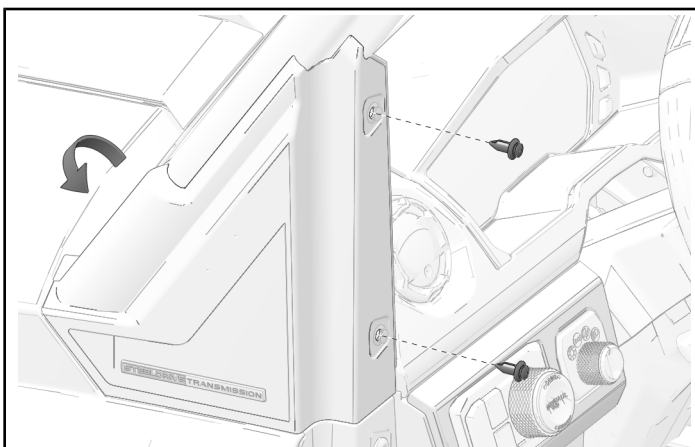
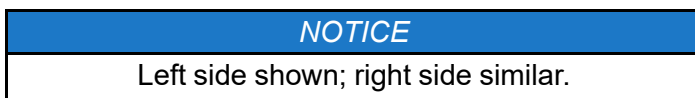

2. Locate dimples on A-pillar cover.

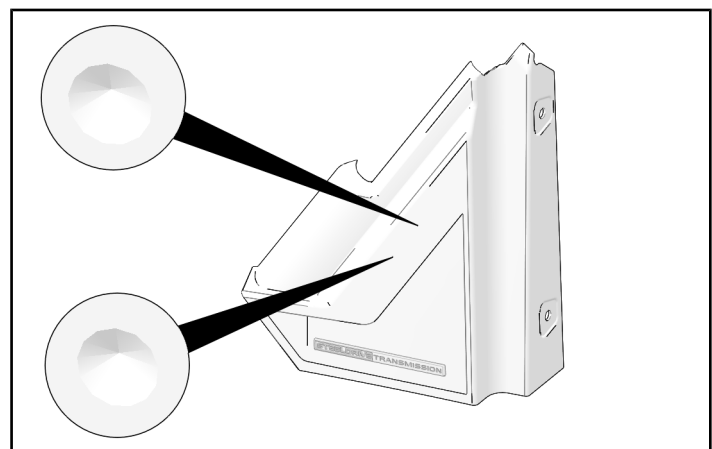
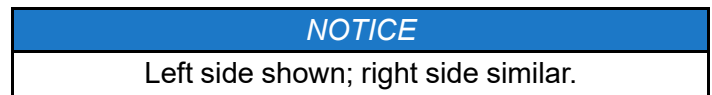

3. Drill one hole at each dimple.

NOTICE

Left side shown; right side similar.

MEASUREMENT

5/8 inch (15.8 mm) Drill Bit

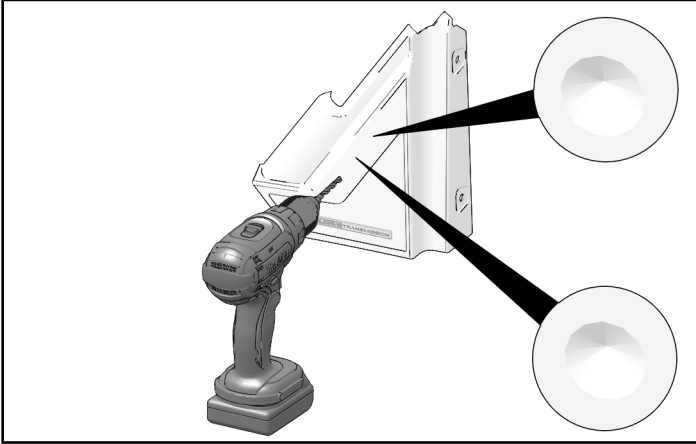

4. Loosely install two screws ⑦ into bracket ⑤ to align it properly.

NOTICE

Left side shown; right side similar.

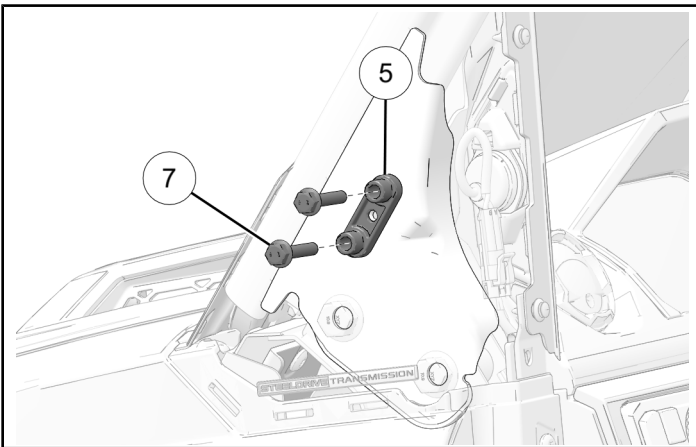

5. Install bracket ⑤ to vehicle frame using one screw ⑥.

NOTICE

Left side shown; right side similar.

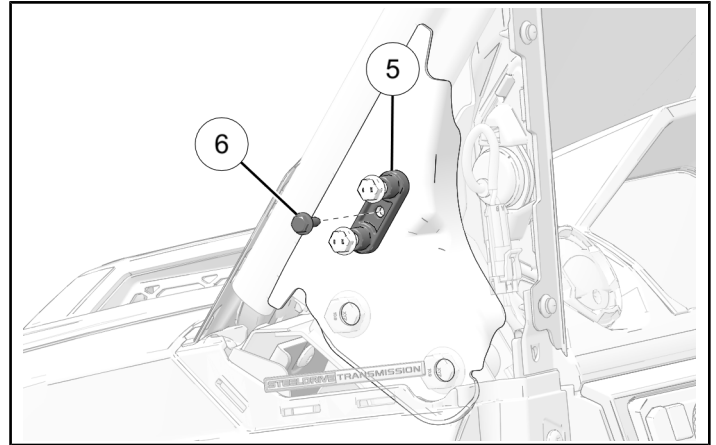

6. Torque screw ⑥ to specification.

TORQUE

Screw ⑥:
9 ft-lbs (12 N·m)

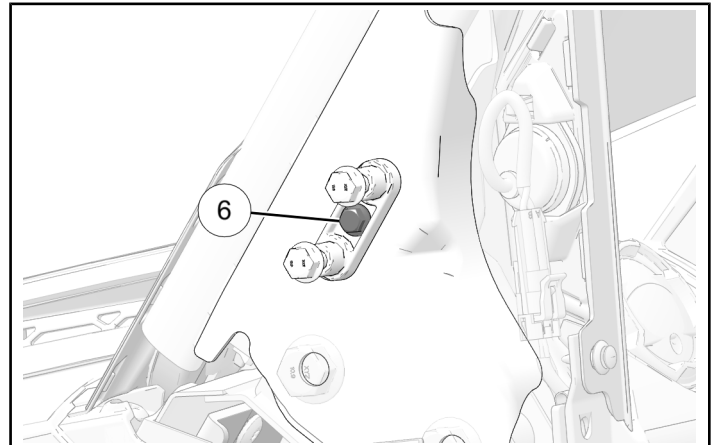

7. Remove and keep two screws ⑦ from bracket assembly.

NOTICE

Left side shown; right side similar.

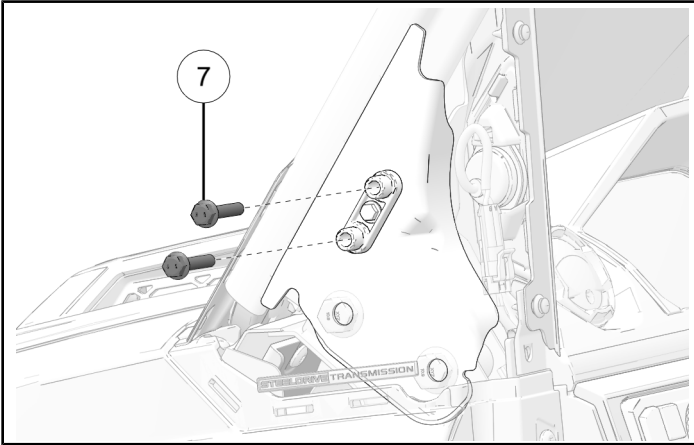

8. Install A-pillar cover using two kept push-pin rivets, make sure A-pillar cover tabs engage body plastic.

NOTICE

Left side shown; right side similar.

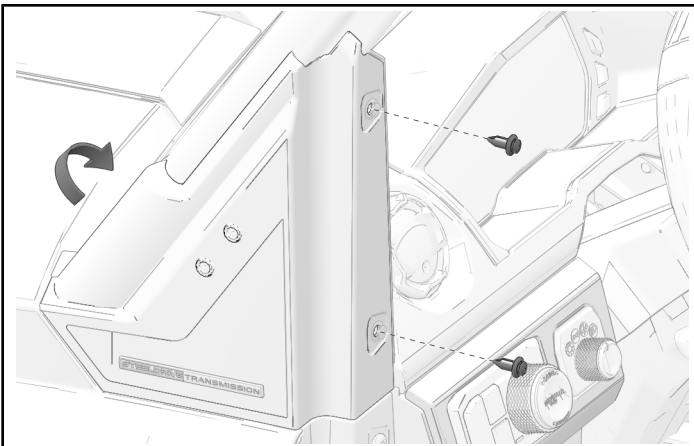

9. Install mirror assembly ① to bracket using two screws ⑦.

NOTICE

Left side shown; right side similar.

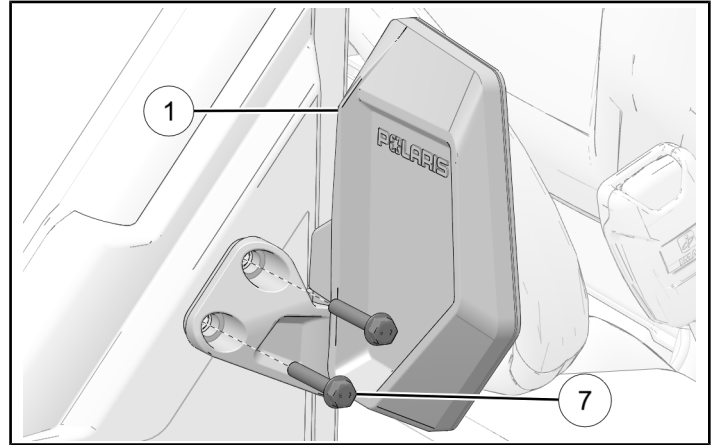

10. Torque screws ⑦ to specification.

TORQUE

Screws ⑦:
18 ft-lbs (25 N·m)

