

RZR PRO XP/TURBO R RIDE COMMAND + PLUG-IN MOUNT KIT



P/N 2889796

BEFORE YOU BEGIN

Read these instructions and check to be sure all parts and tools are accounted for. Please retain these installation instructions for future reference and parts ordering information.

APPLICATION

Verify accessory fitment at www.polaris.com.

REQUIRED SOLD SEPARATELY

Only parts for installation of the RZR Pro XP/Turbo R RIDE COMMAND+ Plug-In Mount Kit are included. For complete installation, the following additional kit is required (sold separately):

- RIDE COMMAND+ Plug-In 500k, P/N 2890039
- Polaris® application is required (available in Android and Apple app stores. Search “Polaris®”).

KIT CONTENTS

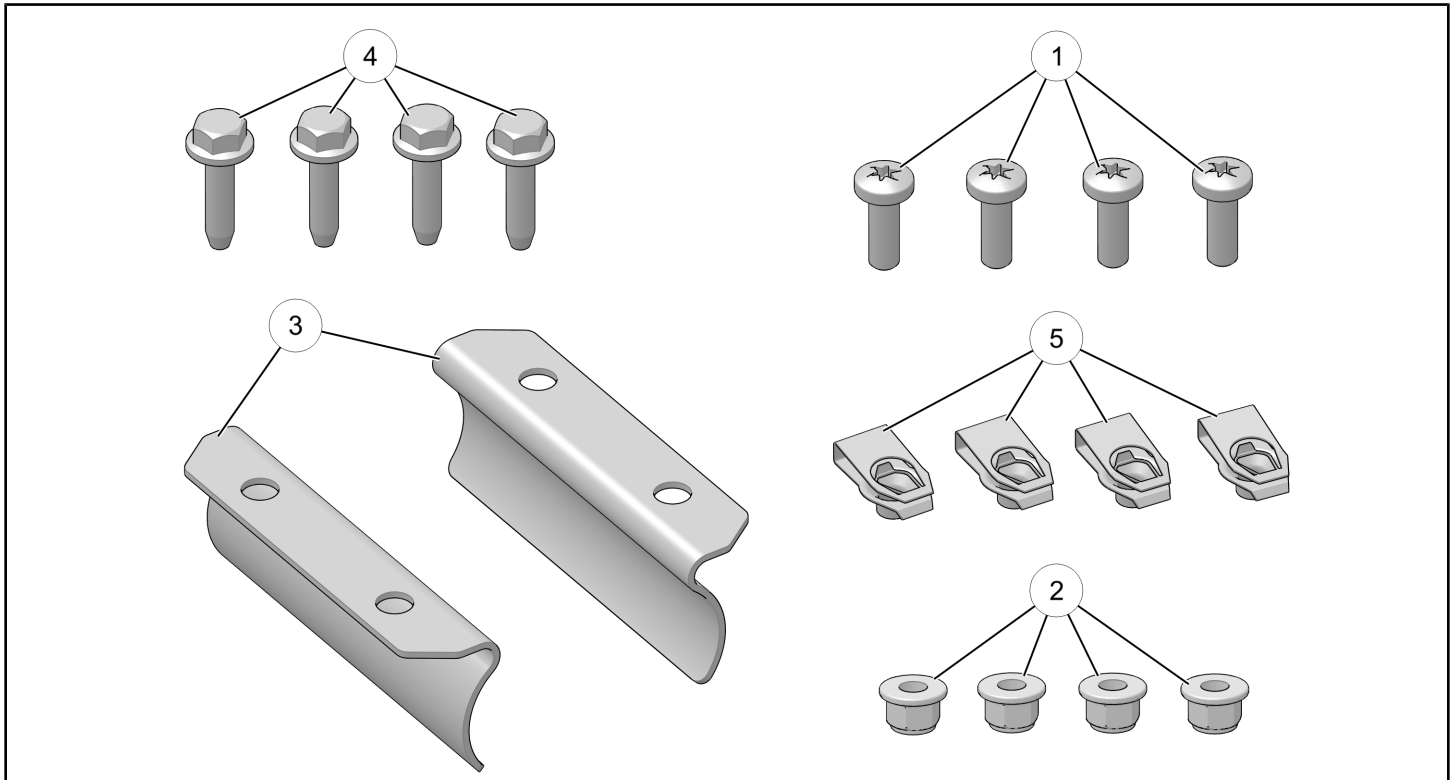

REF	QTY	PART DESCRIPTION	P/N AVAILABLE SEPARATELY
1	4	Screw-Torx® Drive Pan Head #14 X .75 in	7519731
2	4	Nut-Flange M6 mm	7547274
3	2	Bracket (Not Used)	n/a

REF	QTY	PART DESCRIPTION	P/N AVAILABLE SEPARATELY
4	4	Screw-Hex Flange Head, M6 X 1.0 X 25 mm (Not Used)	7519342
5	4	U-Clip, M6 X 1.0 mm (Not Used)	7547366

TOOLS REQUIRED

- Safety Glasses
- Socket Set, Metric
- Pliers, Push Pin Rivet
- Socket Set, Torx® Bit
- Torque Wrench

IMPORTANT

Your RZR Pro XP/Turbo R RIDE COMMAND+ Plug-In Mount Kit is exclusively designed for your vehicle. Please read the installation instructions thoroughly before beginning. Installation is easier if the vehicle is clean and free of debris. For your safety, and to ensure a satisfactory installation, perform all installation steps correctly in the sequence shown.

INSTALLATION INSTRUCTIONS

VEHICLE PREPARATION

GENERAL

1. Park vehicle on a flat surface.
2. Shift vehicle into PARK.
3. Turn key to OFF position and remove key.

CENTER HOOD PANEL REMOVAL

1. Remove and keep two hood fasteners. Move hood towards rear of vehicle to remove.

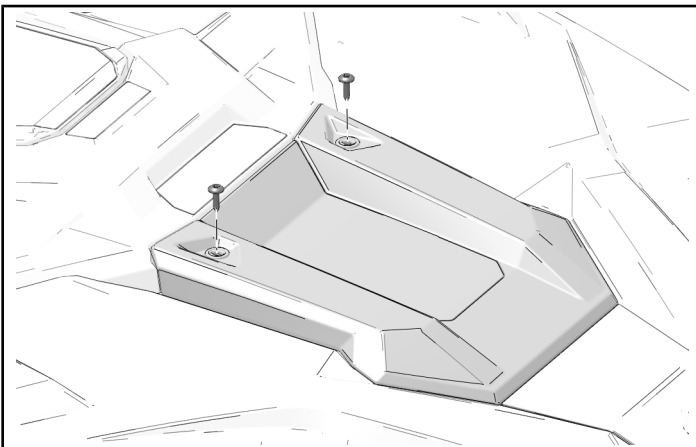

LEFT HOOD DISASSEMBLY

1. Remove and keep one fastener to remove front hood panel.

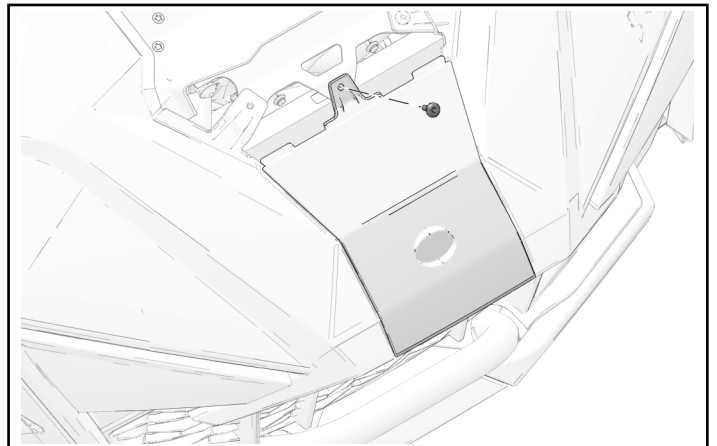

2. Remove and keep three front fender fasteners.

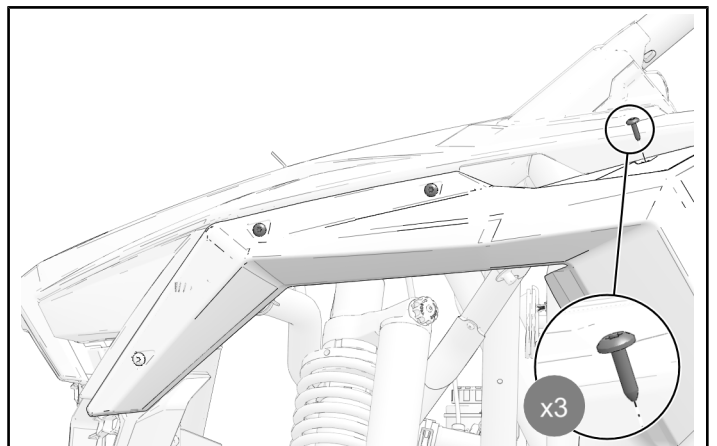

3. Remove and keep three hood fasteners.

TIP

Note fastener installation locations. Fastener configuration may change depending on model and year.

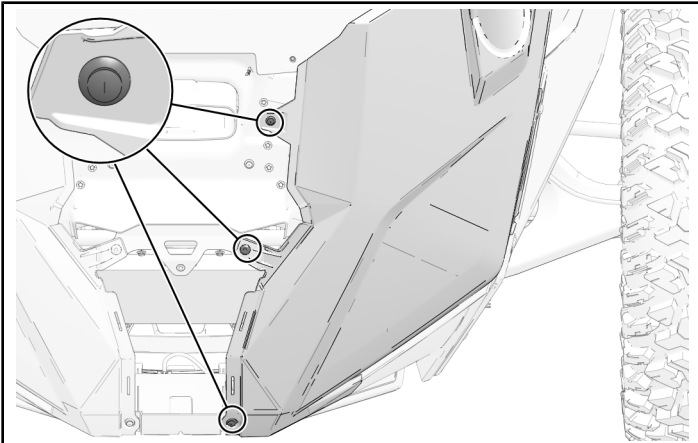

ACCESSORY INSTALLATION

INSTALL RIDE COMMAND+ PLUG-IN

1. Find four pre-drilled holes in hood liner.

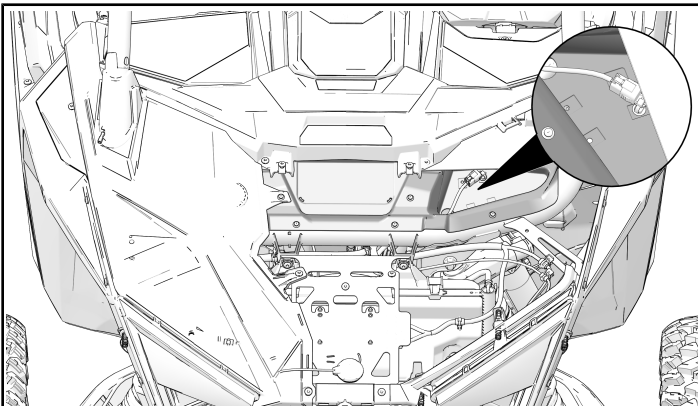

2. Disconnect connector from plug cap. Remove plug cap from vehicle.

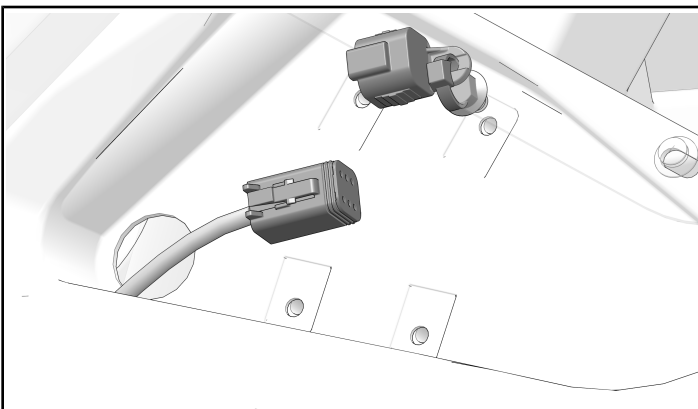

3. Install RIDE COMMAND+ Plug-In and four screws ① into the pre-drilled holes.

NOTICE

RIDE COMMAND+ Plug-In may need to be installed 180° from orientation shown if chassis harness connector does not reach RIDE COMMAND+ Plug-In connector.

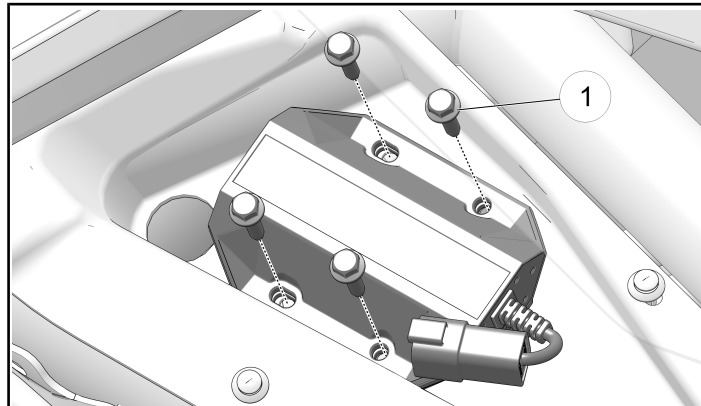

4. Install four screws ① with four nuts ②. Torque nuts to specification.

TORQUE

Nut ②:
35 in-lbs (4 N·m)

NOTICE

Vehicle partially hidden for clarity.

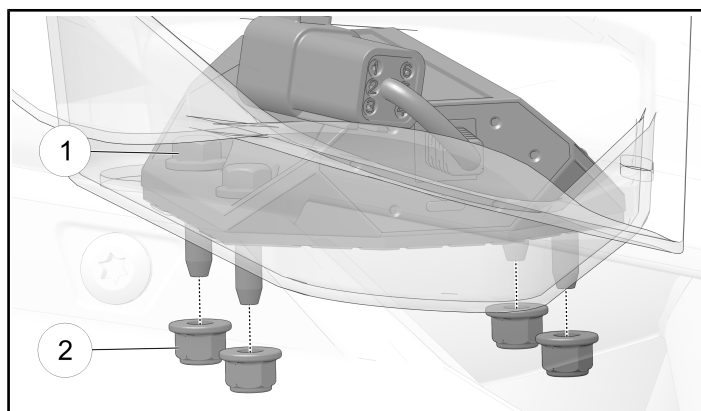

5. Pull main wire harness 6 pin female connector (A) through hole in hood liner.

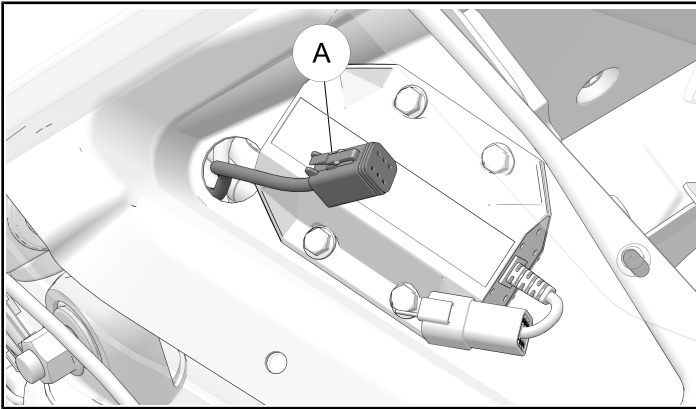

6. Connect main wire harness connector (A) to RIDE COMMAND+ Plug-In connector.

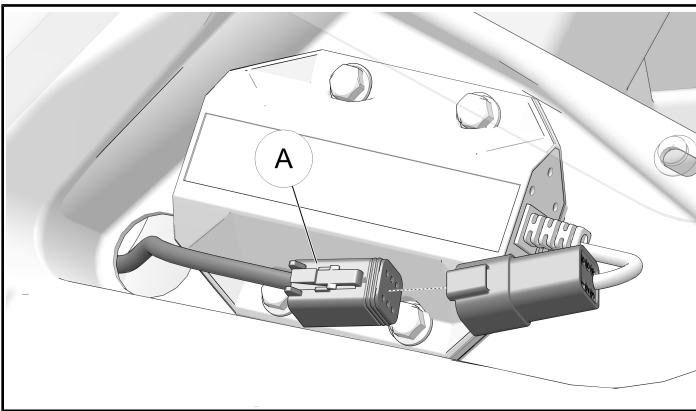

VEHICLE REASSEMBLY

LEFT HOOD PANEL ASSEMBLY

1. Install push-pin rivets where originally located and threaded fastener(s) where originally located.

TORQUE

Hood Fasteners:
88 in-lbs (10 N·m)

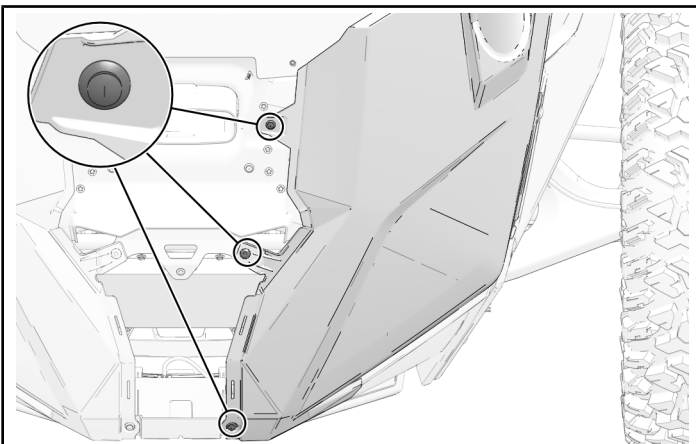

2. Install three retained front fender fasteners. Torque fender fasteners to specification.

TORQUE

Fender Fasteners:
88 in-lbs (10 N·m)

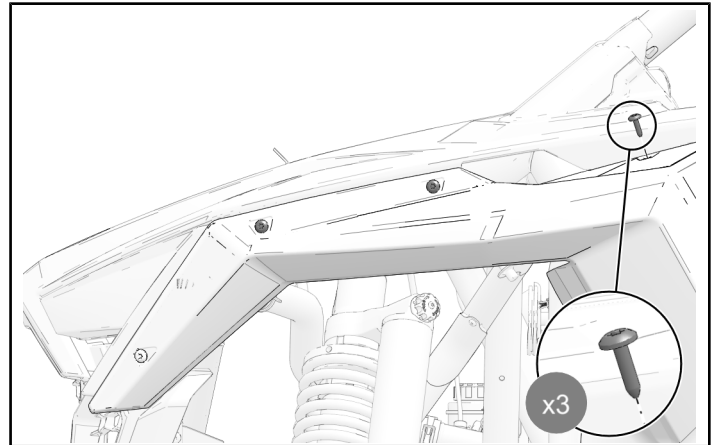

3. Install front hood panel with one retained fastener.

TORQUE

Hood Fasteners:
88 in-lbs (10 N·m)

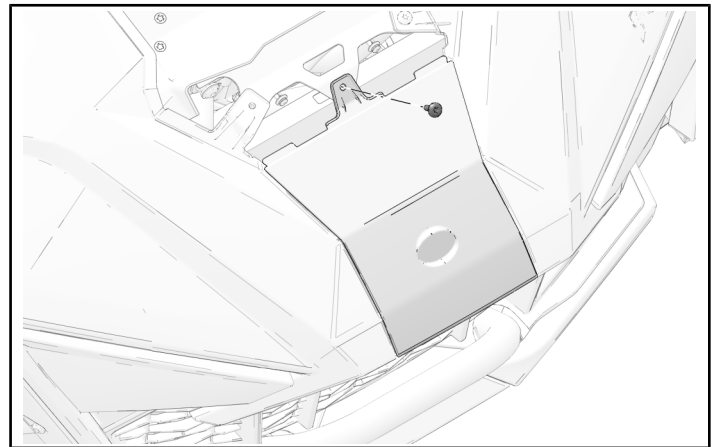

CENTER HOOD PANEL INSTALLATION

1. Move panel forward until tabs slide into front hood panel and install with two hood fasteners.

TORQUE

Hood Fasteners:
88 in-lbs (10 N·m)

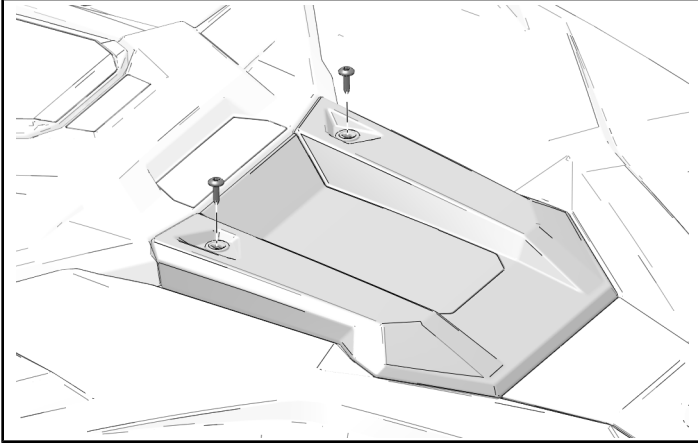

OPERATION

POLARIS® APP

Download the Polaris® App for the Apple or Android device that will be used with RIDE COMMAND+ Plug-In device. Follow the setup procedure in the app.

