

MOLLE PANEL KIT



P/N 2889478

MISSING OR DAMAGED PARTS

Before beginning assembly, inspect the kit and its component(s) to be sure all parts and tools are accounted for and not damaged. If missing parts or parts are damaged, please contact your Selling Dealer for assistance.

If your accessory was purchased online, please contact POLARIS® customer service at **1-800-POLARIS** (US & Canada only).

APPLICATION

Verify accessory fitment at www.polaris.com.

IMPORTANT

This MOLLE Panel Kit cannot be used with the Rhino Overbed Rack Kit (Part #2889453)

KIT CONTENTS

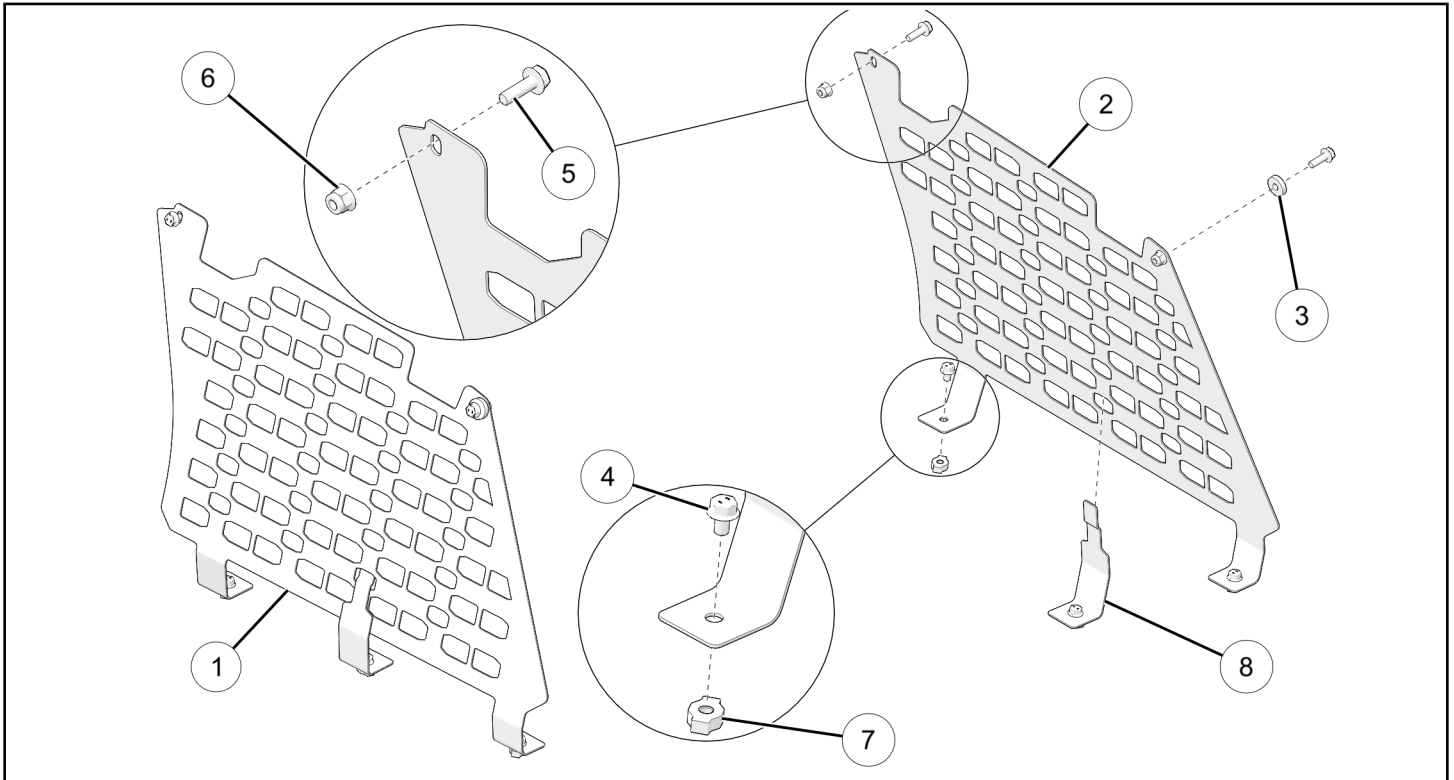

REF	QTY	PART DESCRIPTION	P/N AVAILABLE SEPARATELY	AVAILABLE SERVICE KIT
1	1	Molle Panel – Rear, Left	n/a	n/a
2	1	Molle Panel – Rear, Right	n/a	n/a
3	2	Spacer, 8.5 x 25 x 6 mm	n/a	2209292
4	6	Screw – Hex Flange Head, M8 x 1.25 x 12 mm	7521332-12	2209292
5	4	Screw – Hex Flange Head, M8 x 1.25 x 25 mm	7521332-25	2209292

REF	QTY	PART DESCRIPTION	P/N AVAILABLE SEPARATELY	AVAILABLE SERVICE KIT
6	4	Nut – Hex Flange, M8 x 1.25 mm	7548028	2209292
7	6	Nut – T, M8 x 1.25 mm	n/a	2209292
8	2	Leg – Molle Panel	5465482	n/a

TOOLS REQUIRED

- Safety Glasses
- Socket Set, Metric
- Torque Wrench
- Wrench Set, Metric

IMPORTANT

Your MOLLE Panel Kit is exclusively designed for your vehicle. Please read the installation instructions thoroughly before beginning. Installation is easier if the vehicle is clean and free of debris. For your safety, and to ensure a satisfactory installation, perform all installation steps correctly in the sequence shown.

INSTALLATION INSTRUCTIONS

VEHICLE PREPARATION

GENERAL

1. Park vehicle on a flat surface.
2. Shift vehicle into PARK.
3. Turn key to OFF position and remove key.

LOCK & RIDE® WINDOW REMOVAL (IF EQUIPPED)

NOTICE

Left side shown; right side similar.

1. Turn handles at inside top of window a quarter-turn.

NOTICE

Turn handles so that they point toward rear of vehicle.

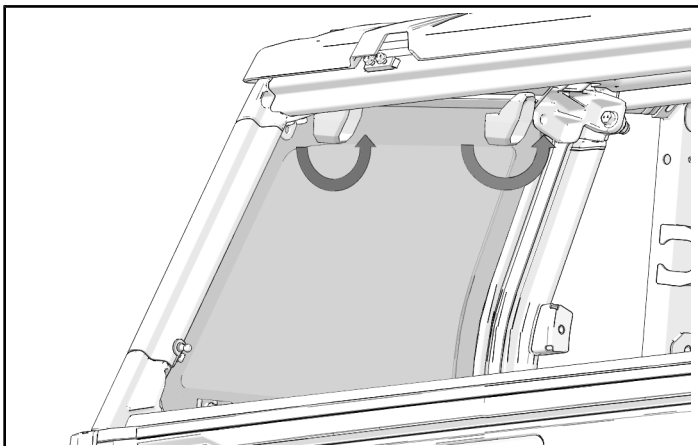

2. Tilt top of window outward.

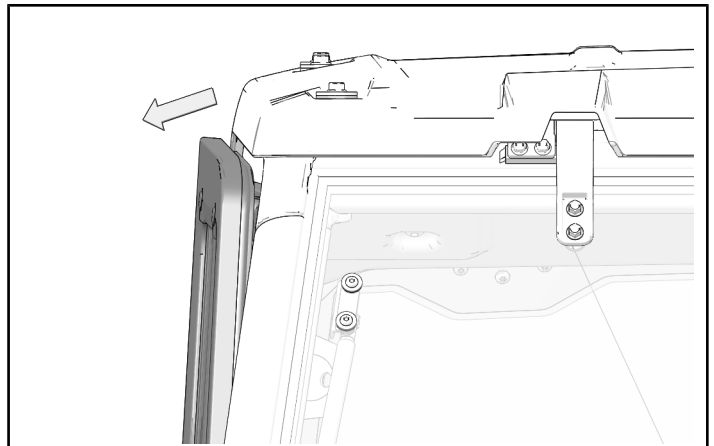

3. Lift window up to remove.

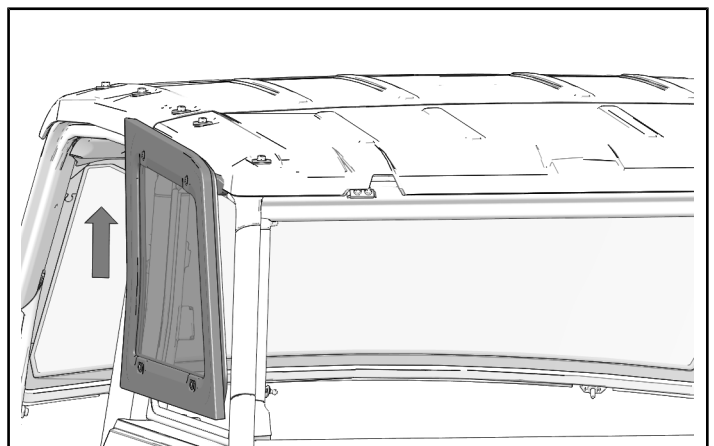

ACCESSORY INSTALLATION

NOTICE

Left side shown; right side similar.

1. Set MOLLE panel on top of rail and align with top mounting holes. Select positions on rail where lower fasteners will be located. Place T-nuts ⑦ in rail at these locations.

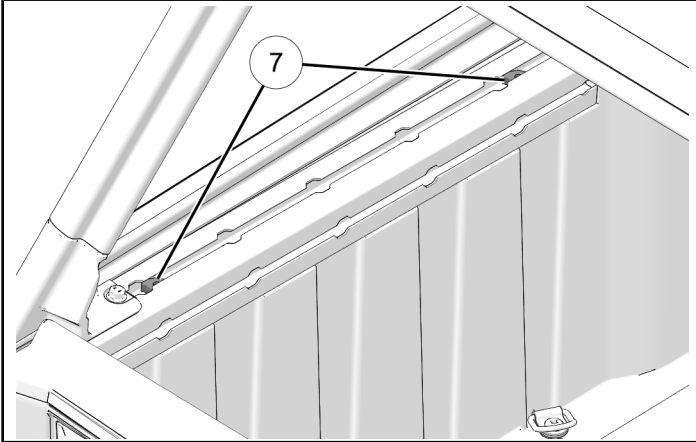

2. Loosely install MOLLE panel ① to rail. Use two screws ④ to install panel. Align top holes in MOLLE panel to holes in enclosure.

Do not torque fasteners at this time.

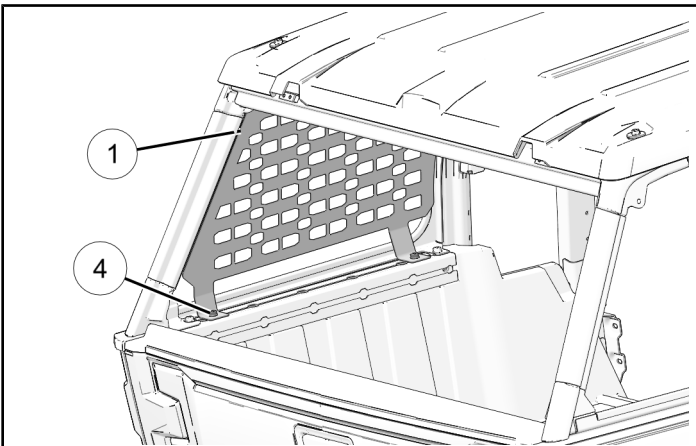

3. Install upper mounting hardware. Use screw ⑤ and nut ⑥ in hole closest to front of vehicle. Use screw ⑤, nut ⑥, and spacer ③ in hole closest to rear of vehicle. Position spacer between MOLLE panel and enclosure, as shown. Torque screws to specification.

TORQUE

Screws ⑤:
24 ft-lbs (32 N·m)

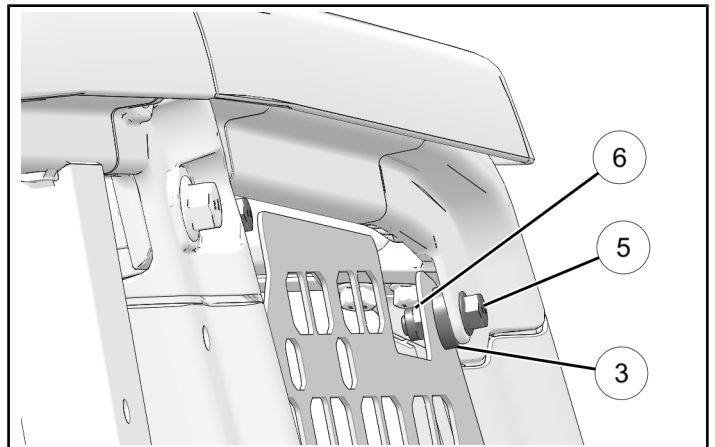
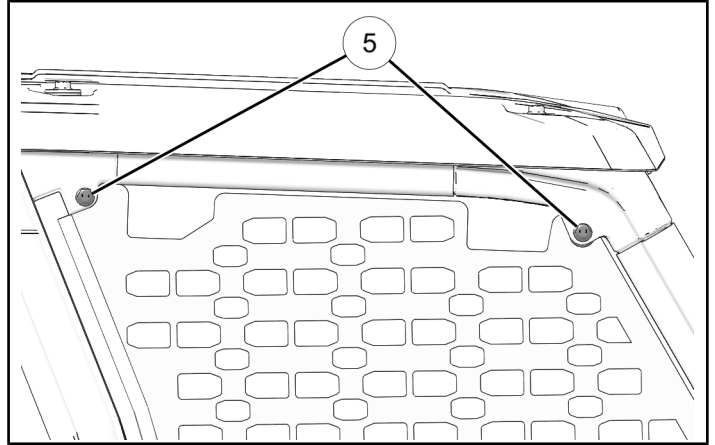

4. Insert t-nut ⑦ in rail.

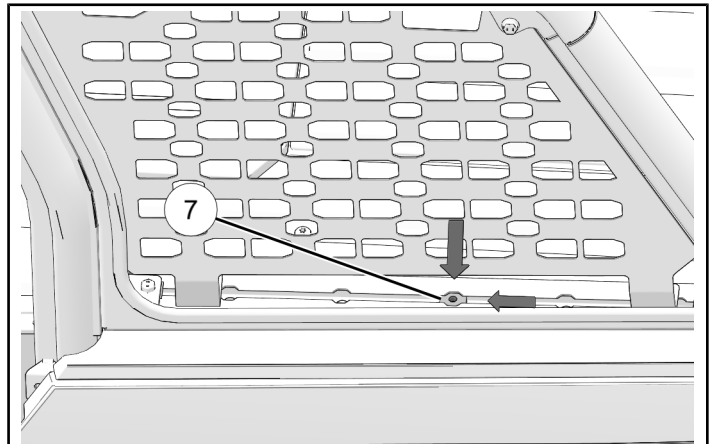

5. Push top half of leg ⑧ through hole in MOLLE panel, as shown.

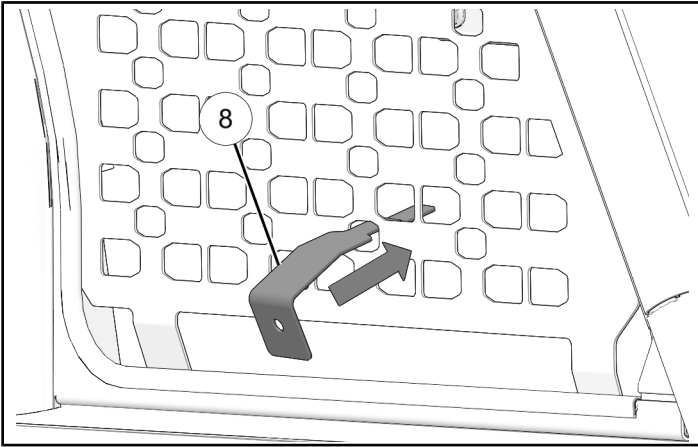

6. Push bottom of leg ⑧ toward rail, and lower leg until it rests on rail.

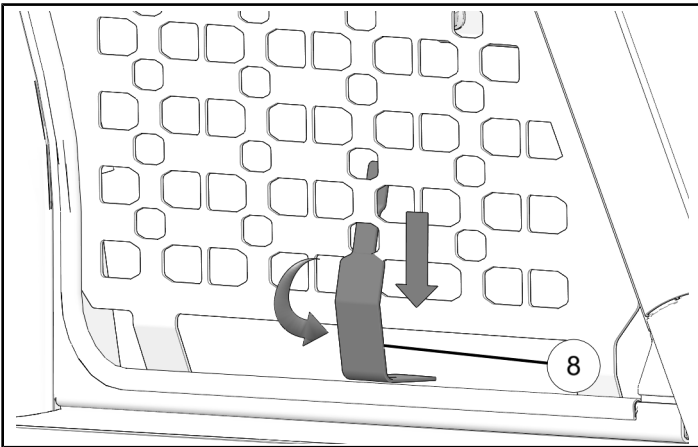

7. Install screw ④ for leg. Tighten lower screws ④ to specification.

TORQUE

Screws ④:
24 ft-lbs (32 N·m)

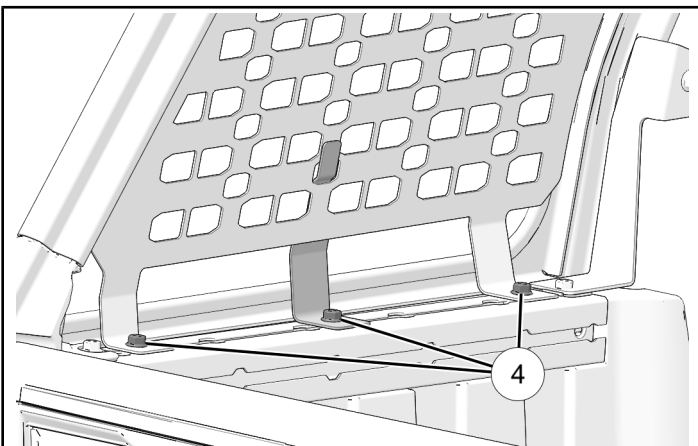

8. Repeat steps for right side MOLLE panel.
9. Re-install Lock & Ride® windows if desired.

VEHICLE REASSEMBLY

LOCK AND RIDE® WINDOW INSTALLATION

NOTICE

Left side shown; right side similar.

1. Lower window into position. Lower mounting brackets on window install over bottom of window frame.

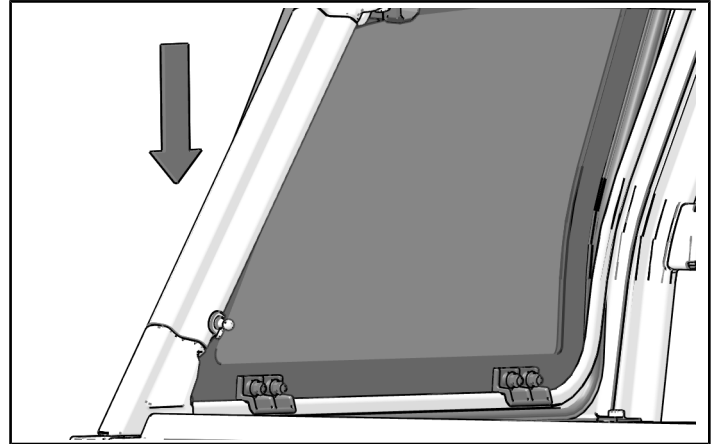

2. Tilt top of window into window frame.

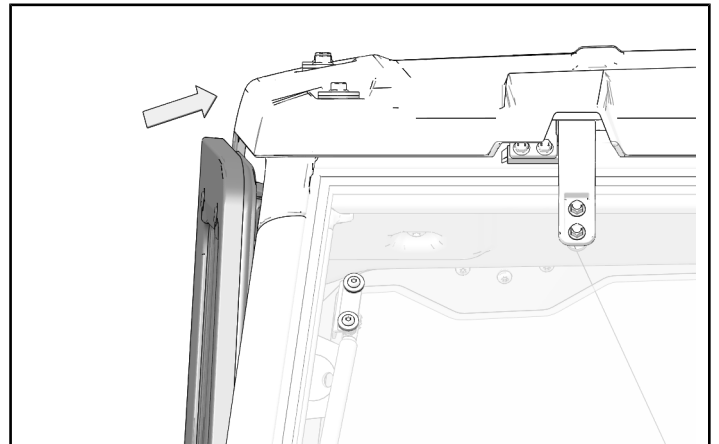

3. Turn handles upward to lock window into place.

