

FENDER FLARE KIT



P/N 2889133

BEFORE YOU BEGIN

Read these instructions and check to be sure all parts and tools are accounted for. Please retain these installation instructions for future reference and parts ordering information.

APPLICATION

Verify accessory fitment at www.polaris.com.

KIT CONTENTS

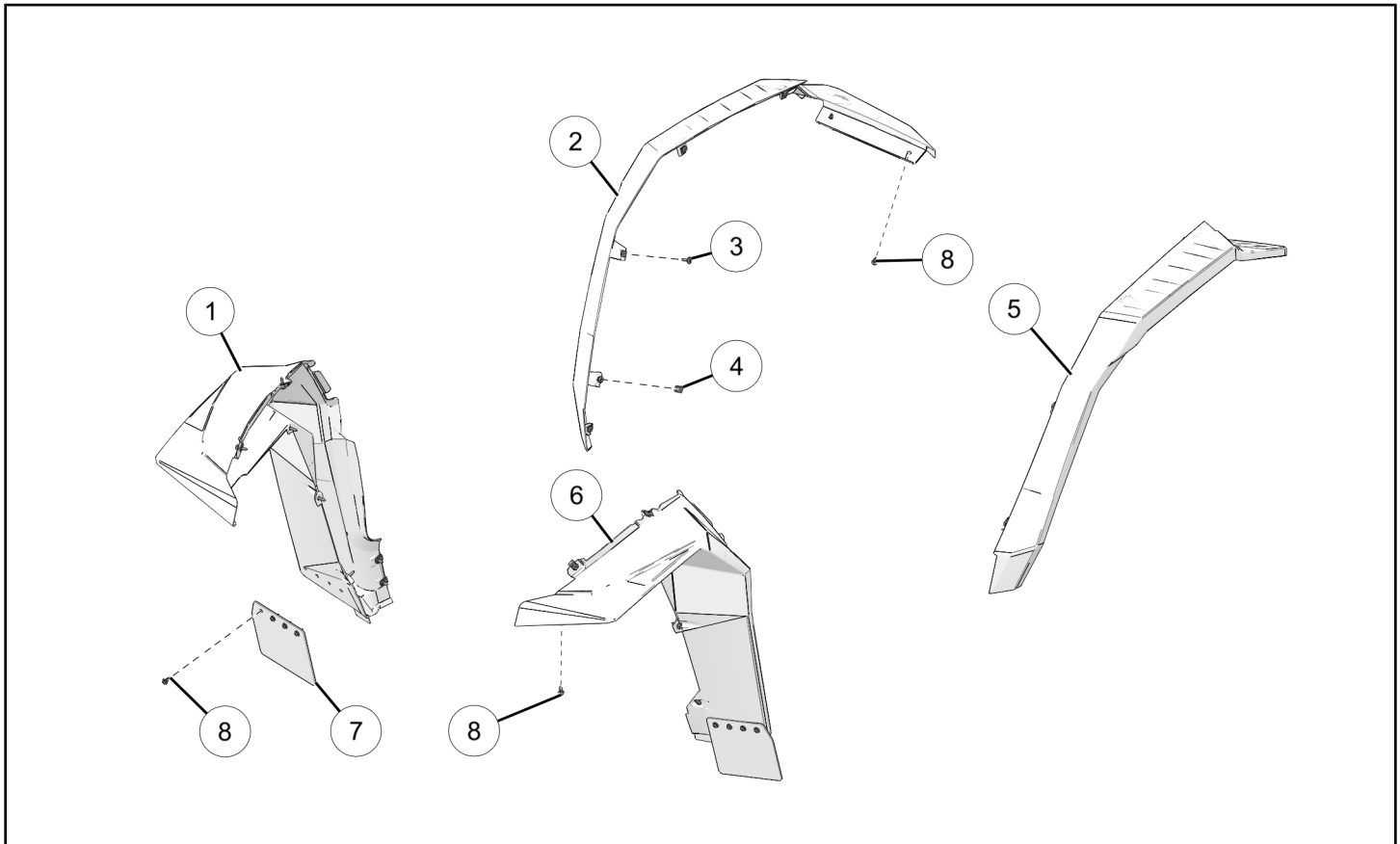

REF	QTY	PART DESCRIPTION	P/N AVAILABLE SEPARATELY
1	1	Flare-Fender, Front, Right-Hand	n/a
2	1	Flare-Fender, Rear, Right-Hand	n/a
3	22	Screw-Torx® Truss Head, M6 x 1.0 x 25 mm	7519650
4	18	Nut-U, Clip, M6 x 1.0 mm	7547674
5	1	Flare-Fender, Rear, Left-Hand	n/a
6	1	Flare-Fender, Front, Left-Hand	n/a
7	2	Flap-Fender Flare	5417748

REF	QTY	PART DESCRIPTION	P/N AVAILABLE SEPARATELY
8	14	Rivet-Push-Pin, 0.315 x 0.325 x 0.787 in	7661855
9	2	Screw-Torx® M6 x 1.0 x 16 mm (not shown)	7518936

TOOLS REQUIRED

- Safety Glasses
- Drill
- Drill Bit:
 - 1/4 in (6.5 mm)
 - 5/16 in (8 mm)
- Pliers, Push Pin Rivet
- Socket Set, Metric
- Socket Set, Torx® Bit
- Torque Wrench

IMPORTANT

Your Fender Flare Kit is exclusively designed for your vehicle. Please read the installation instructions thoroughly before beginning. Installation is easier if the vehicle is clean and free of debris. For your safety, and to ensure a satisfactory installation, perform all installation steps correctly in the sequence shown.

INSTALLATION INSTRUCTIONS

VEHICLE PREPARATION

GENERAL

1. Park vehicle on a flat surface.
2. Shift vehicle into PARK.
3. Turn key to OFF position and remove key.

HOOD REMOVAL

1. Remove and keep two hood fasteners. Move hood rearward to remove.

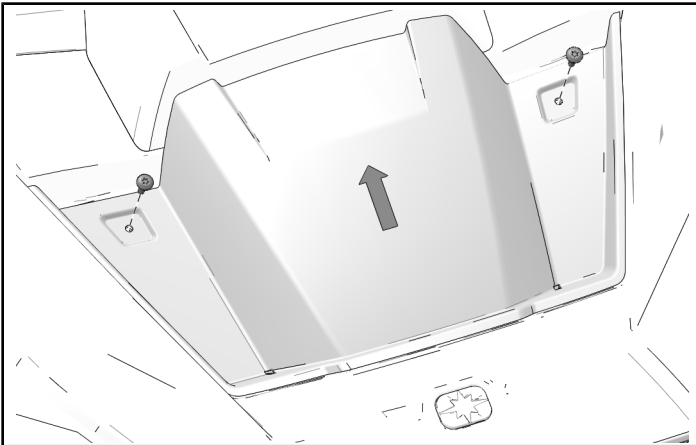

OUTER HOOD REMOVAL

1. Gently insert flat head screwdriver under rear seam of front pocket fender.

NOTICE

Left side shown, right side similar.

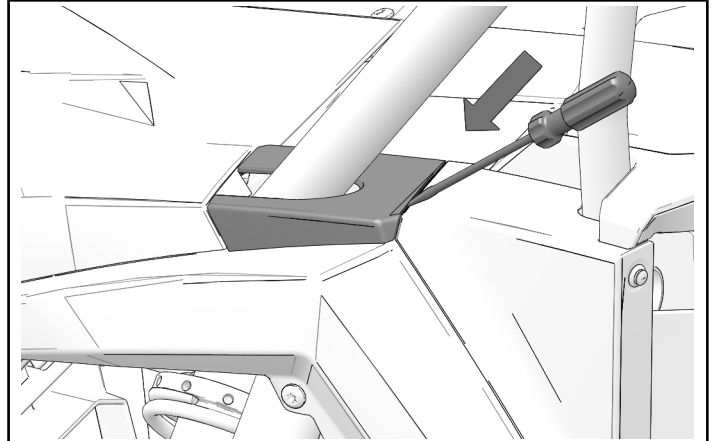

2. Slide flat head screwdriver under front pocket fender.

NOTICE

Left side shown, right side similar.

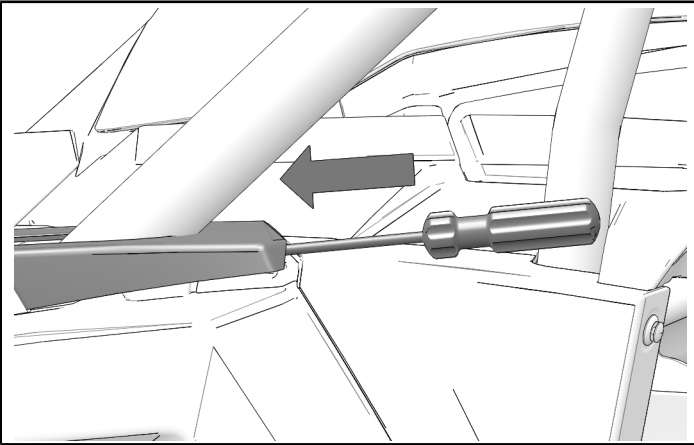

3. Gently lift screwdriver upward to free front pocket fender from clips.

NOTICE

Left side shown, right side similar.

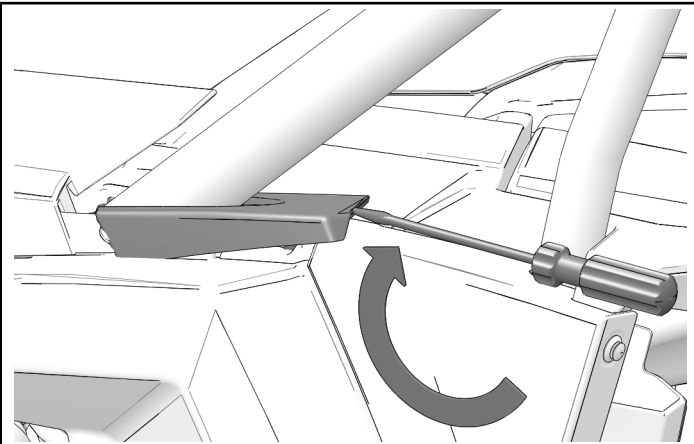

4. Remove and keep front pocket fender.

NOTICE

Left side shown, right side similar.

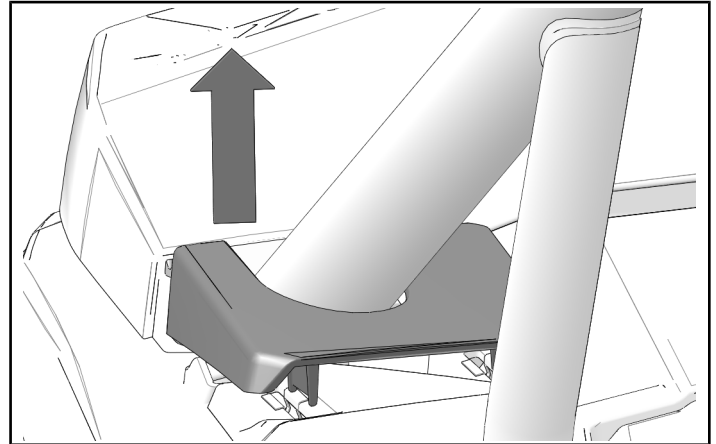

5. Remove and keep four outer hood fasteners.

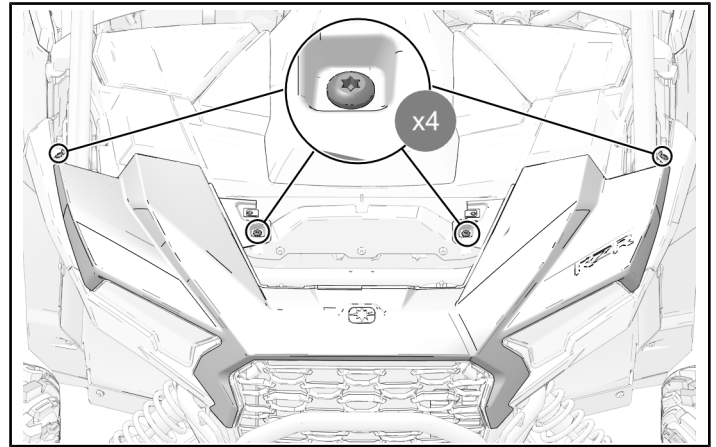

6. Remove outer hood from vehicle.

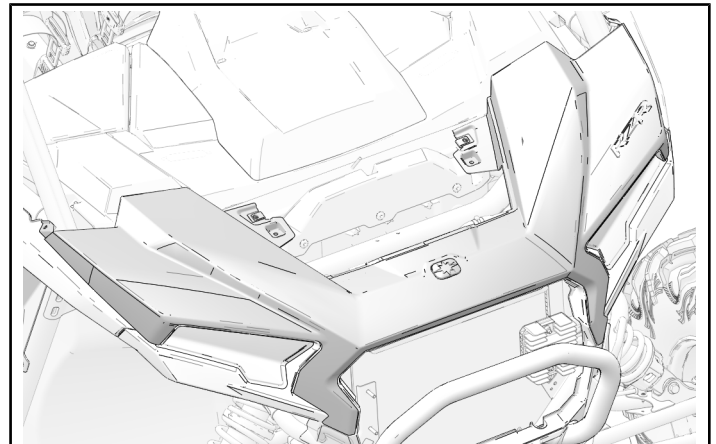

REAR POCKET FENDER REMOVAL

NOTICE

Left fender flare shown; right fender flare similar.

1. Remove 2 push-pin rivets from rear pocket fender.

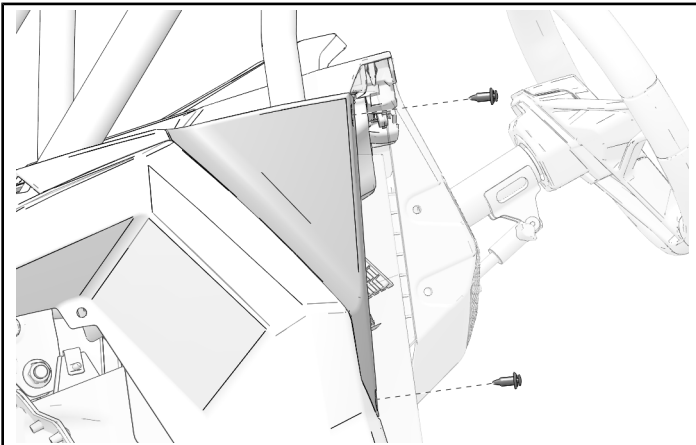

2. Rotate rear pocket fender away from vehicle body and remove.

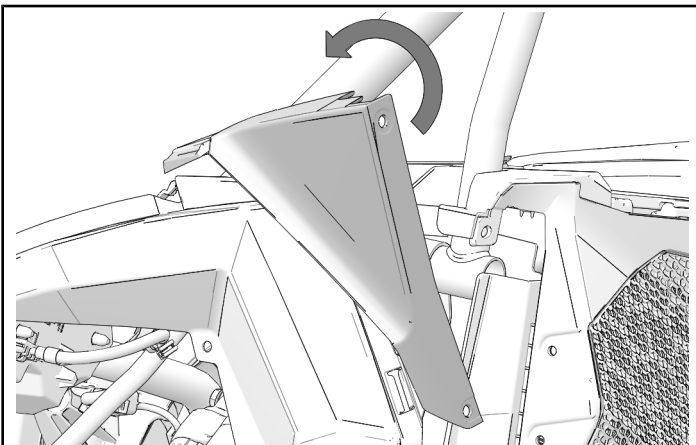

FRONT FENDER FLARE REMOVAL

NOTICE

Left fender flare shown; right fender flare similar.

1. Remove seven screws and remove fender flare.

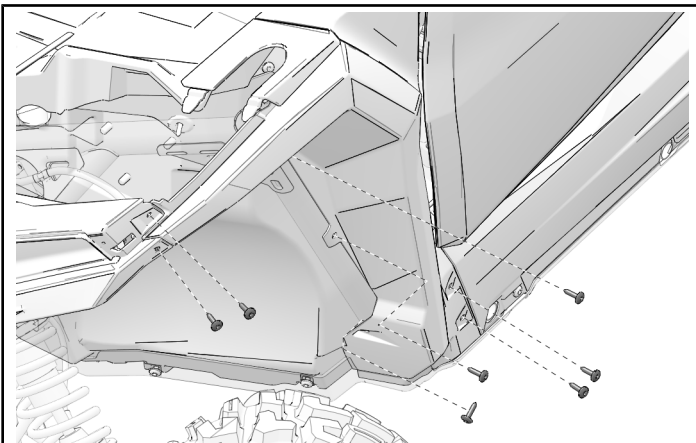

REAR FENDER FLARE REMOVAL

NOTICE

Left fender flare shown; right fender flare similar.

1. Remove four screws and remove fender flare.

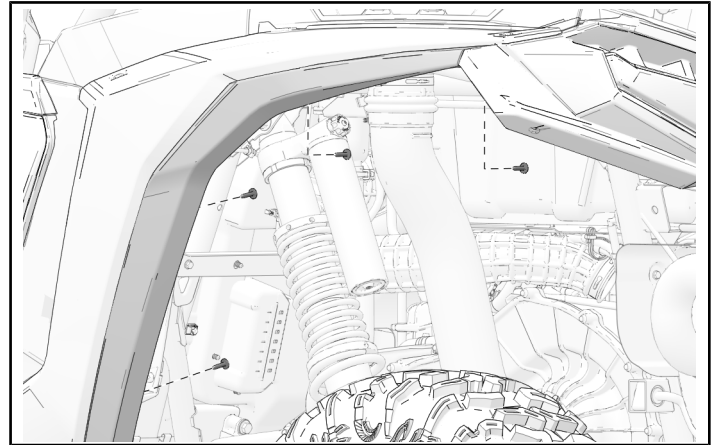

ACCESSORY INSTALLATION

FRONT FENDER FLARE

NOTICE

Left-hand fender flare shown; right-hand fender flare similar.

1. Align fender flare ⑥ with holes in chassis tubes and install with two u-nuts ④.

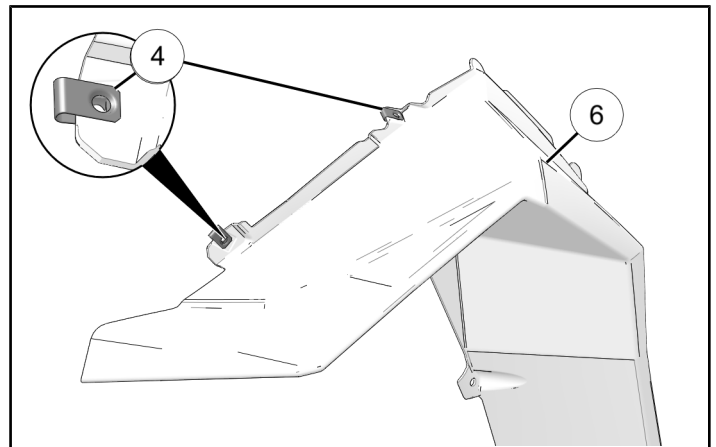

2. Align fender flare ⑥ with vehicle and loosely install to chassis tube with three screws ③.

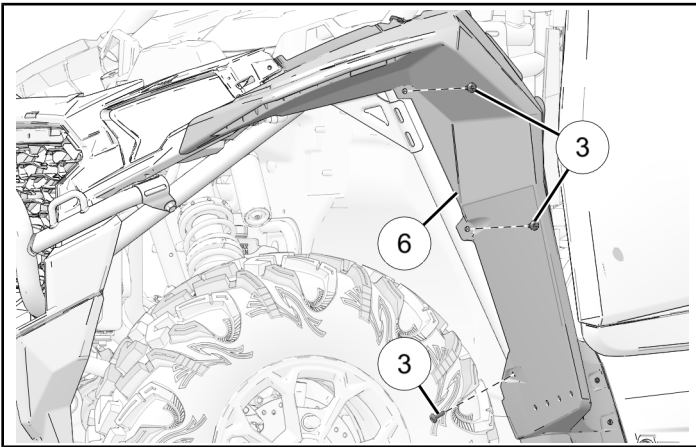

3. Loosely install front fender flare ⑥ with two screws ③.

NOTICE

Do not torque screws at this time.

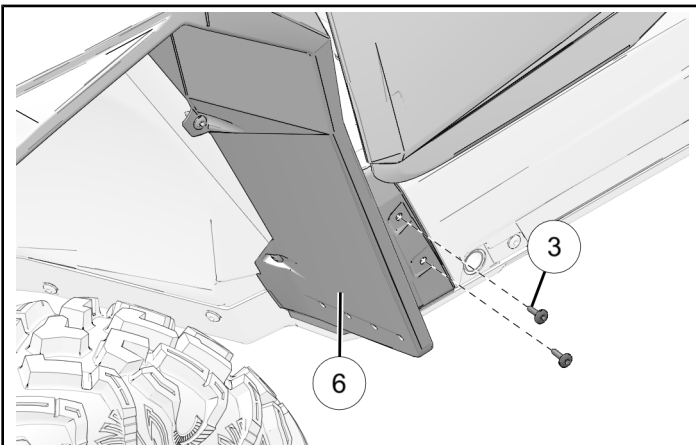

4. Make sure top mounting point of fender flare ⑥ is behind upper front fascia and install with one screw ③.

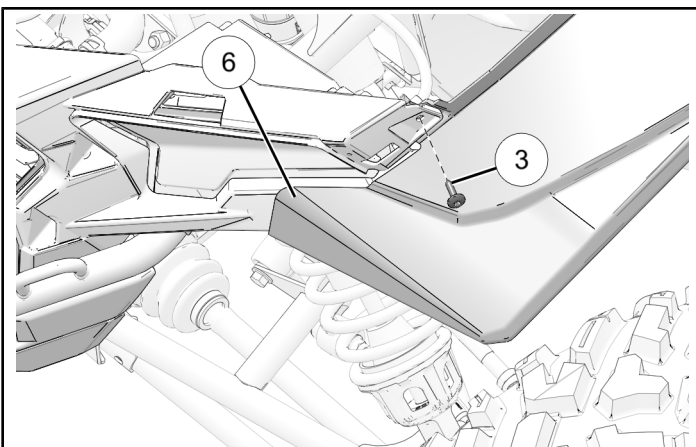

5. Torque all front fender flare screws ③ and ④ to specification.

TORQUE

Front fender flare screws ③:
10 in-lbs (88 N·m)

TORQUE

Nut-U clip ④:
7 ft-lbs (10 N·m)

NOTICE

Screw hidden by XL fender flare is not used

6. Using the flange on the fender flare, drill hole in the front fascia for the push dart ⑧.

MEASUREMENT

Drill bit size:
5/16 in (8 mm)

NOTICE

Headlight housing is directly above drill location.
Control tool depth while drilling.

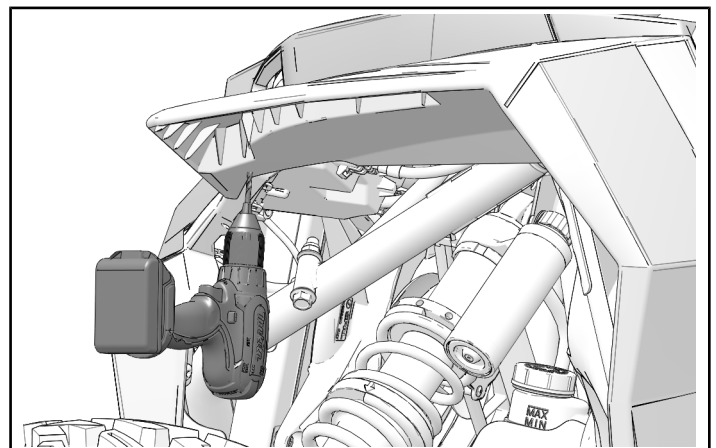

- Align fender flap ⑦ with lower fender flare and install with four push-pin darts ⑧.

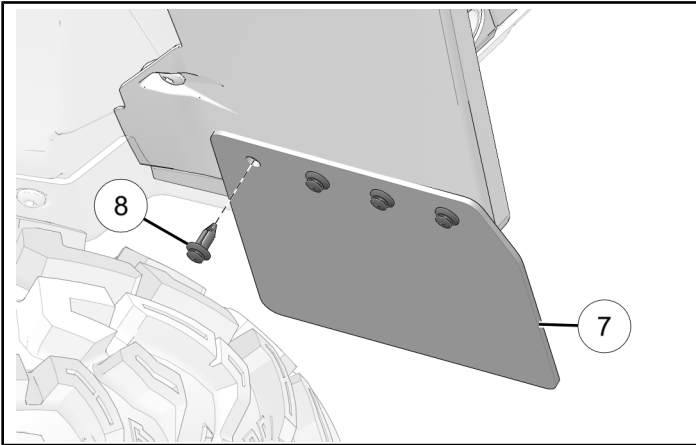

REAR FENDER FLARE

- Remove and retain one rivet holding rear fascia to fascia bracket.

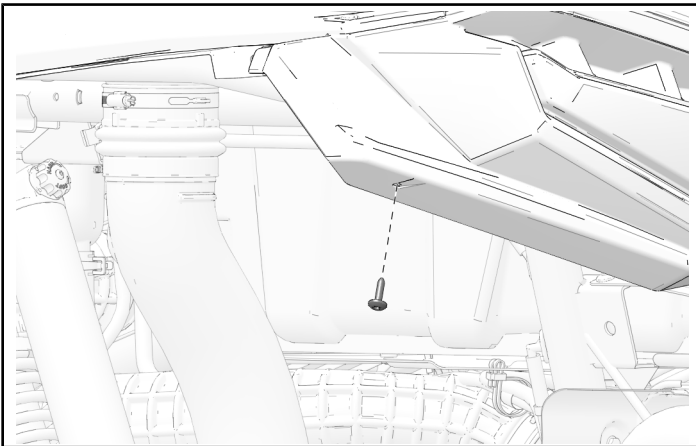

- Install five U-nuts ④ onto rear fender flare ⑤

NOTICE

View from inside of fender flare. Screws will be installed from inside wheel well.

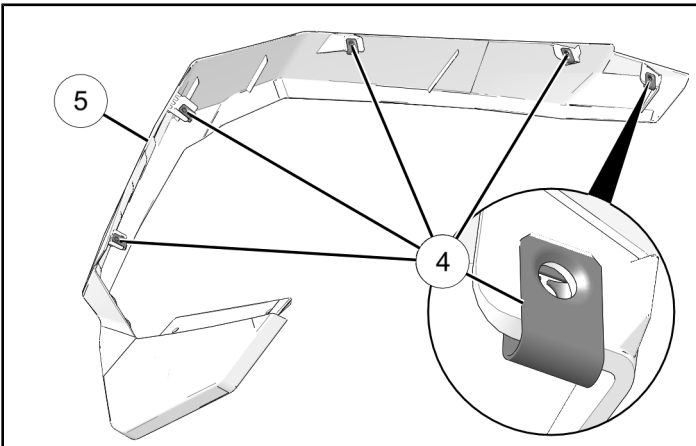

- Align fender flare with screw holes in vehicle and attach with two screws ③.

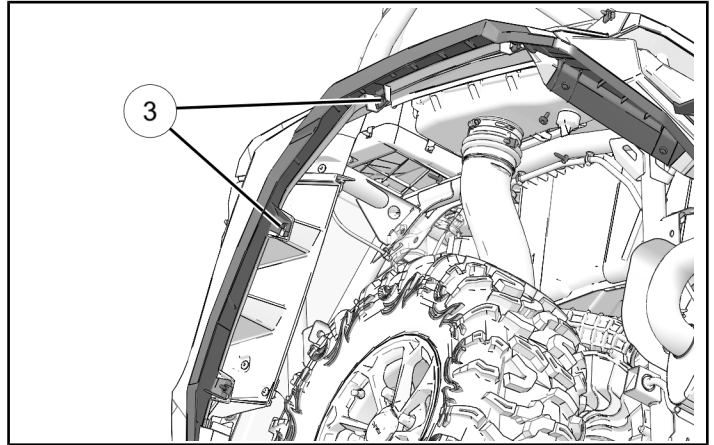

- Install screw ⑨ followed by screw ③. Torque to specifications.

TIP

For best finish, clamp rear fender and rear fascia together to close any visible gaps prior to tightening screws 3 and 9.

TORQUE

Truss head screw ③:
88 in-lbs (10 N·m)

5.

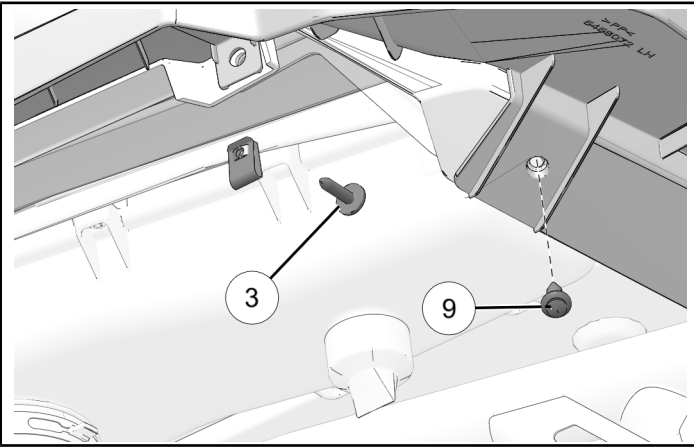

Push rear of fender flare ⑤ inward and align with rear fascia.

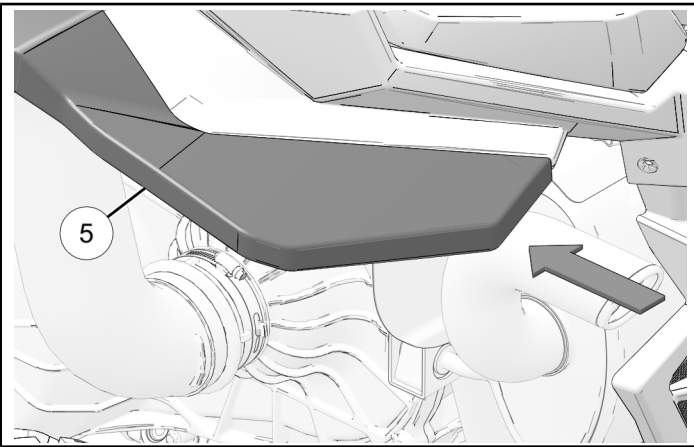

6. Using the innermost hole as a guide, drill one **5/16"** hole into rear fascia for push-pin rivet on inside hole.

Measurement

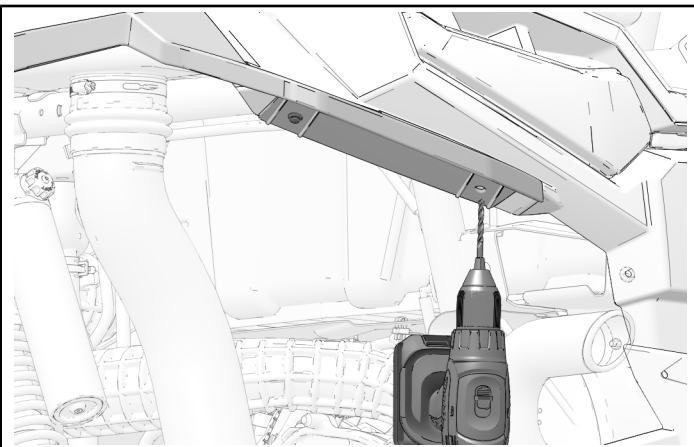

7. Install left rear fender flare ⑤ to rear fascia with one push-pin darts ⑧.

NOTICE

Left rear fender flare ⑤ shown, right rear fender flare ② similar.

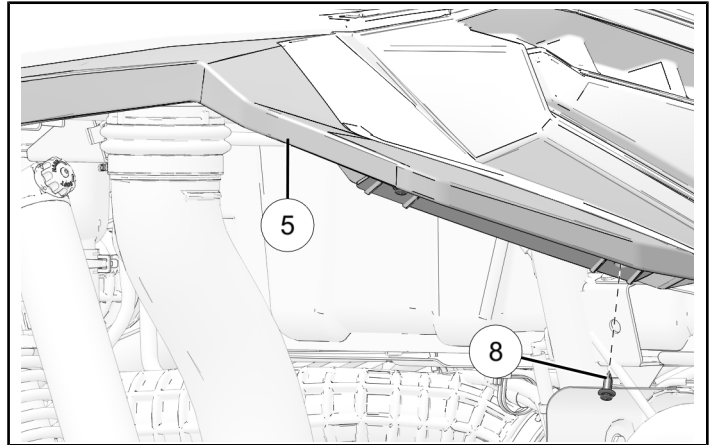

8. Mark rocker panel through lowest fender flare hole.

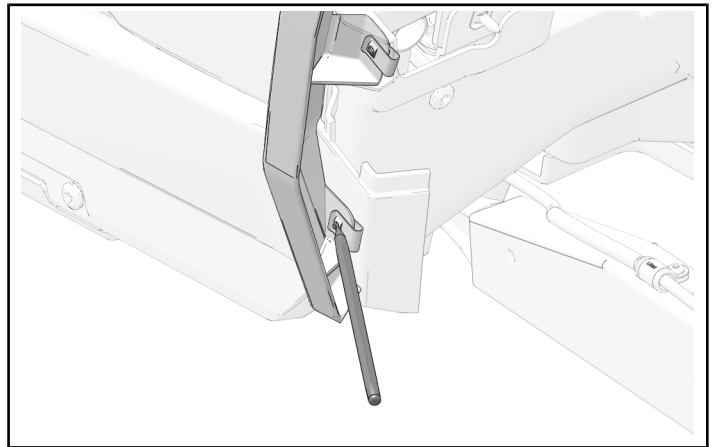

9. Move fender flare ⑤ to the side.

NOTICE

Left rear fender flare ⑤ shown, right rear fender flare ② similar.



10. Drill hole at marked location.

MEASUREMENT

Drill hole size:
1/4 in (6.5 mm)

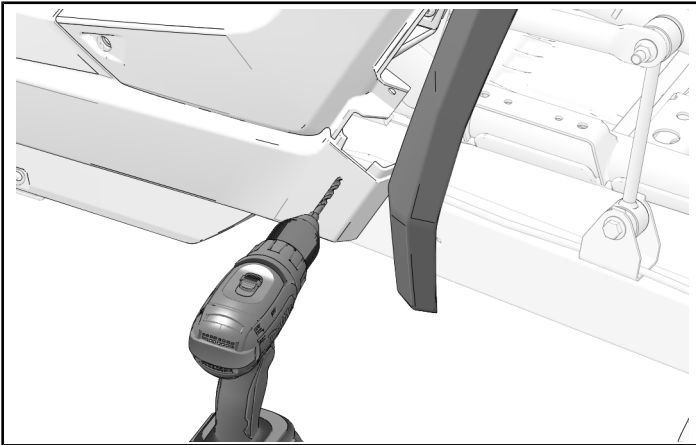

11. Install lower fender flare with two screws ⑨.
Torque two screws to specification.

TORQUE

Rear Fender Flare Screws ⑨:
88 in-lbs (10 N·m)

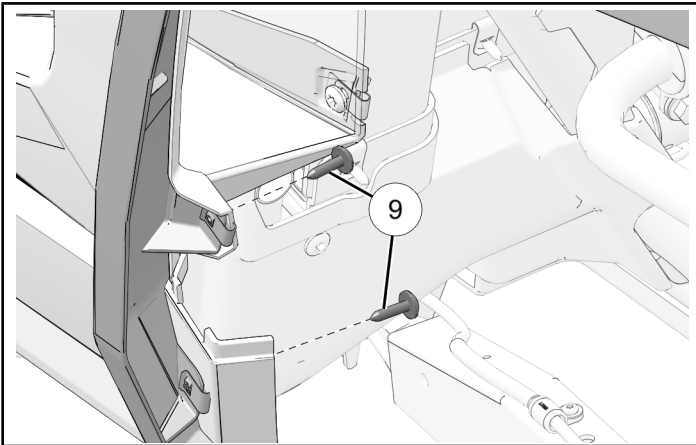

VEHICLE REASSEMBLY

REAR POCKET FENDER INSTALLATION

NOTICE

Left fender flare shown; right fender flare similar.

1. Rotate rear pocket fender towards vehicle body and slide into place.

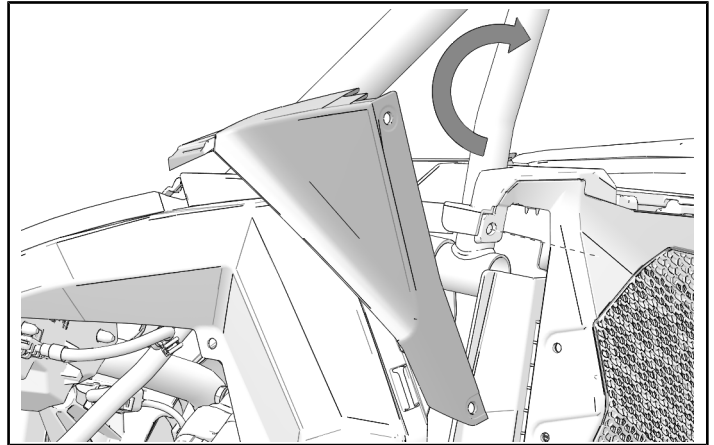

2. Attach rear pocket fender to vehicle using two push-pin rivets.

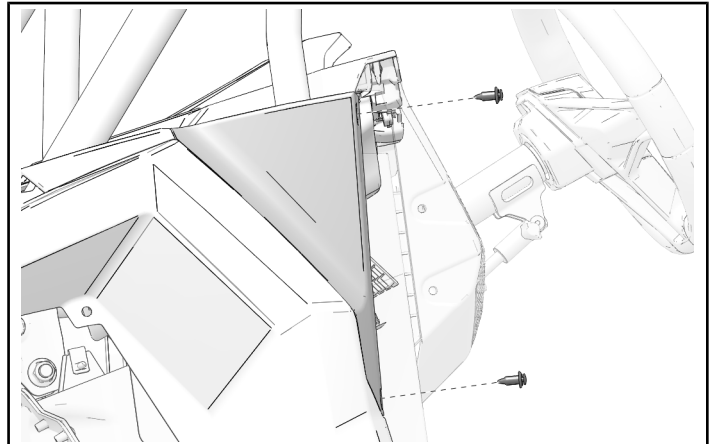

OUTER HOOD INSTALLATION

1. Put outer hood on vehicle in installed position.

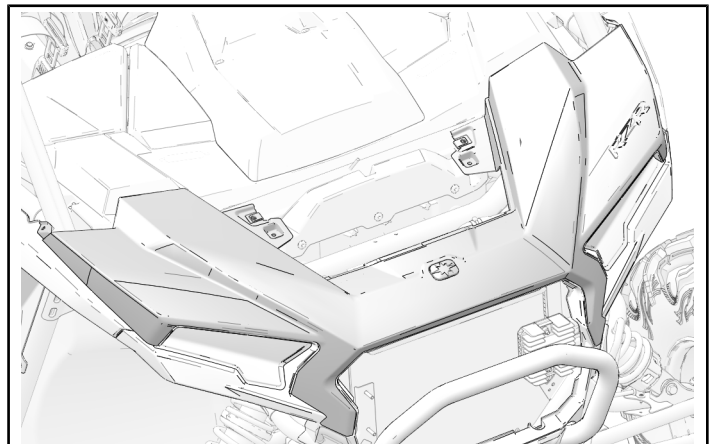

2. Install outer hood fasteners with four retained fasteners. Torque the four fasteners to specification.

TORQUE

Outer Hood Fasteners
88 in-lbs (10 N·m)

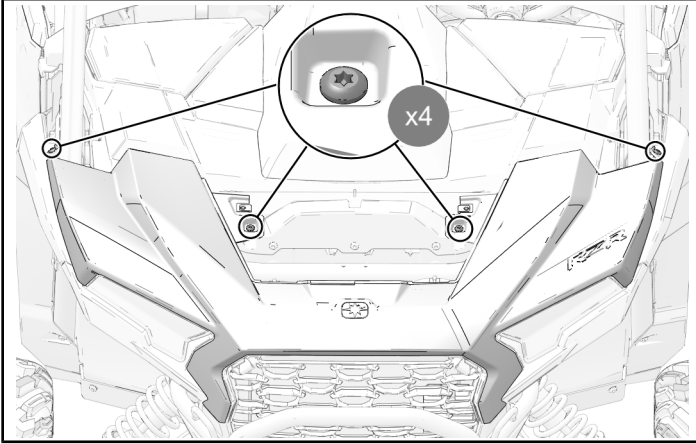

3. Place front pocket fender around ROPS bar and into outer hood slots.

NOTICE

Left side shown, right side similar.

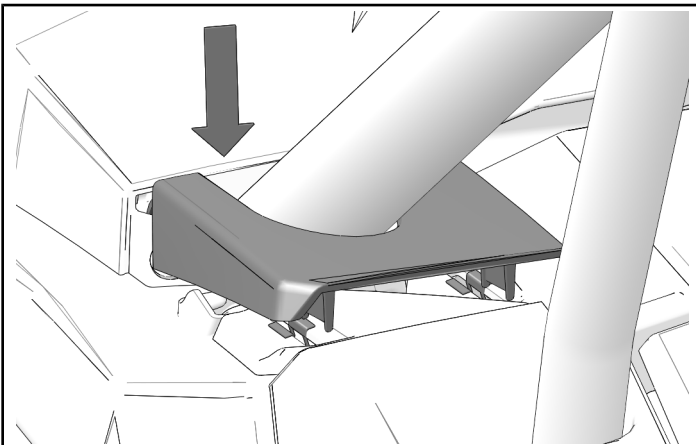

4. Gently push tab into clips until front pocket fender is secure.

NOTICE

Left side shown, right side similar.

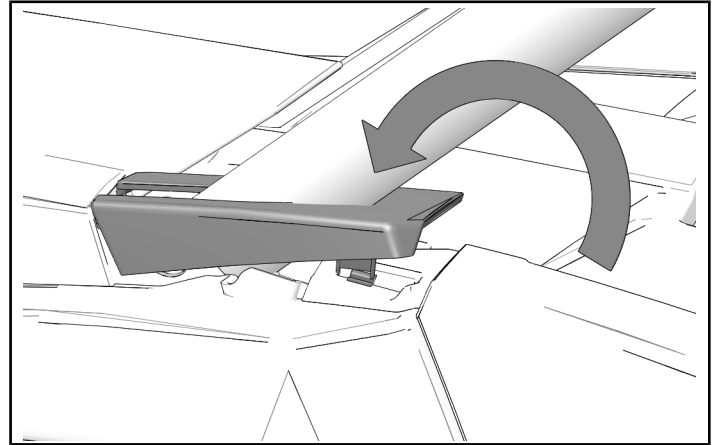

HOOD INSTALLATION

1. Move hood forward, into outer hood panel, and install with two retained fasteners. Torque fasteners to specification.

TORQUE

Hood Fasteners
88 in-lbs (10 N·m)

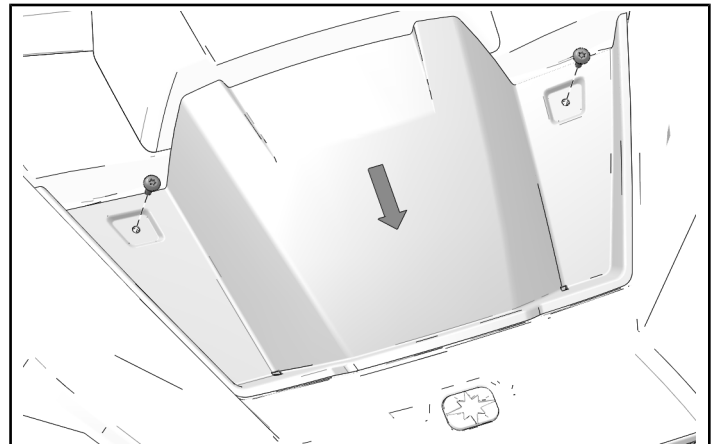

INSTRUCTION FEEDBACK FORM

A feedback form has been created for the installer to provide any comments, questions or concerns about the installation instructions. The form is viewable on mobile devices by scanning the QR code or by clicking [HERE](#) if viewing on a PC.

