

MULTI-POINT HARNESS KIT



P/N 2890046, 2890048, 2890049

BEFORE YOU BEGIN

Read these instructions and check to be sure all parts and tools are accounted for. Please retain these installation instructions for future reference and parts ordering information.

APPLICATION

Verify accessory fitment at www.polaris.com.

KIT CONTENTS

TWO PASSENGER VEHICLES

FRONT HARNESS

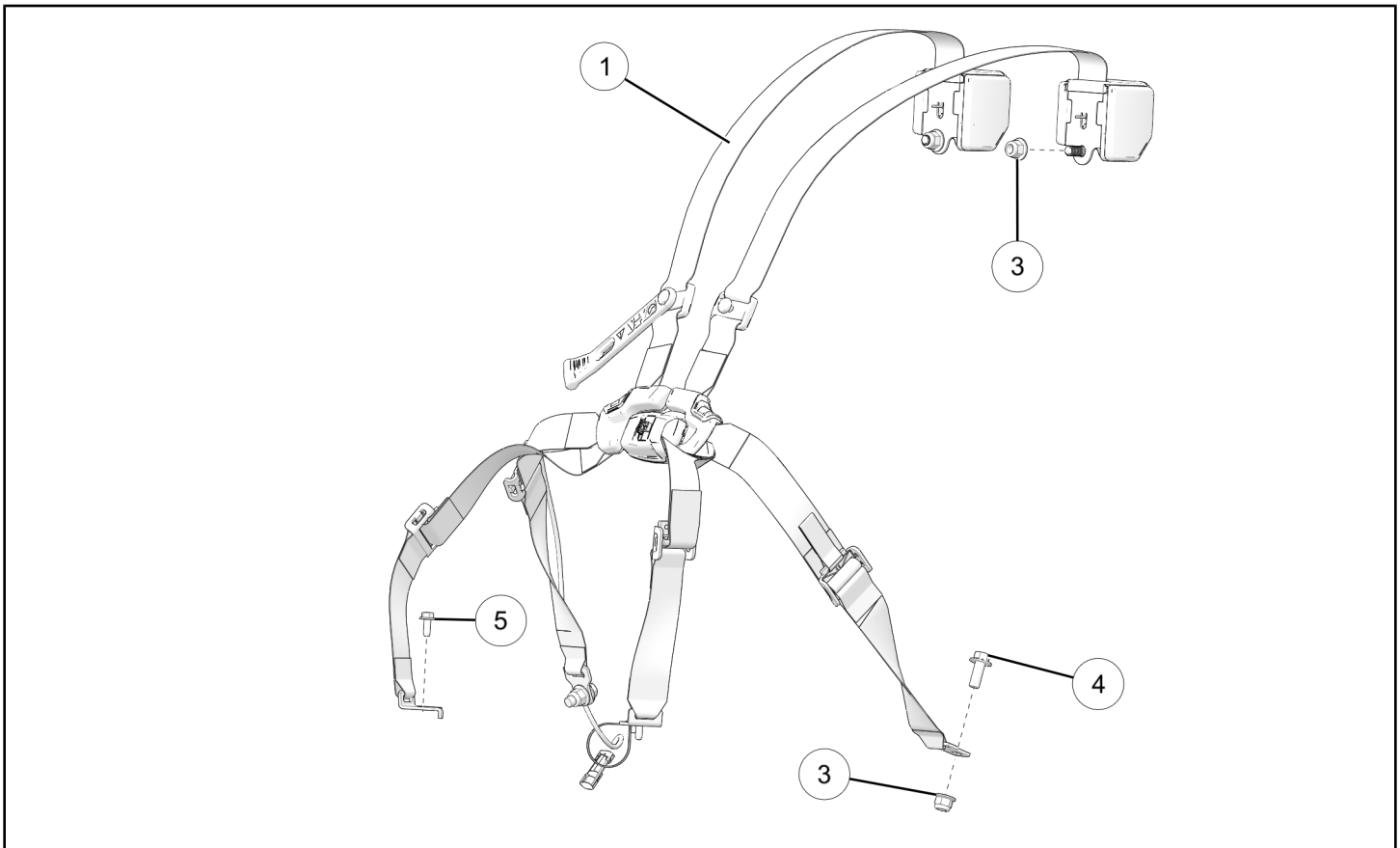

NOTICE

Driver harness shown; passenger harness similar.

REF	QTY	PART DESCRIPTION	P/N AVAILABLE SEPARATELY
1	1	Assembly–Seat Belt Harness, Driver Assembly–Seat Belt Harness, Passenger	2639180 2639181
2	n/a	Not Used	n/a
3	4	Nut–Hex Flange, Nylon Locking, M12 x 1.75 mm	7547441

REF	QTY	PART DESCRIPTION	P/N AVAILABLE SEPARATELY
4	2	Screw–Hex Flange, M12 x 1.75 x 30 mm	7520054
5	2	Screw–Hex Flange, M8 x 1.25 x 20 mm	7518555
6	1	Cable Tie, Driver Harness (not shown)	n/a

MULTI-PASSENGER VEHICLES

FRONT HARNESS

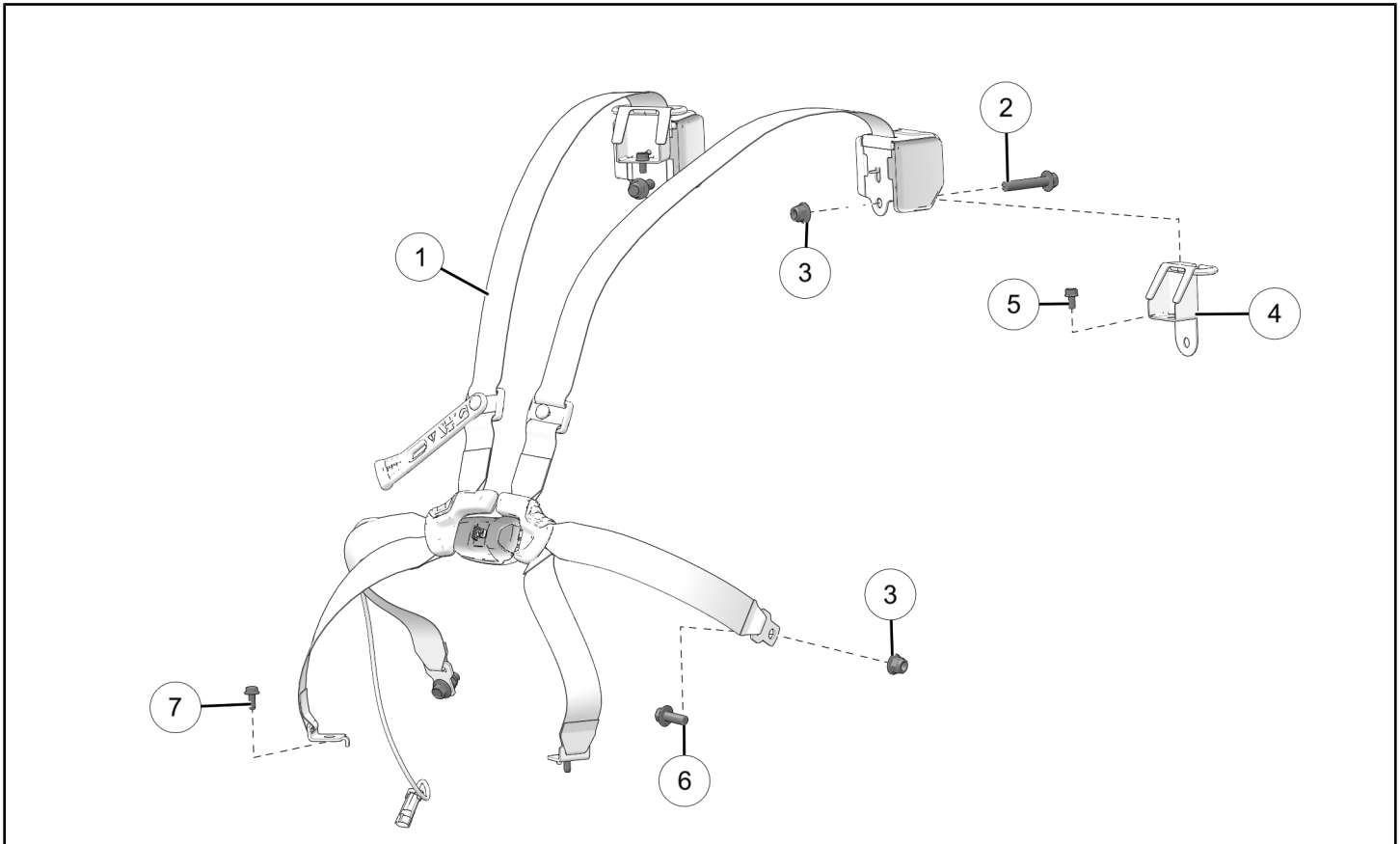

NOTICE

Driver harness shown; passenger harness similar.

REF	QTY	PART DESCRIPTION	P/N AVAILABLE SEPARATELY
1	1	Assembly–Seat Belt Harness, Driver Assembly–Seat Belt Harness, Passenger	2639182 2639183
2	2	Screw–Hex Flange, M12 x 1.75 x 65 mm	7519264
3	4	Nut–Hex Flange, Nylon Locking, M12 x 1.75 mm	7547441
4	2	Bracket–Harness Guide	1027668-458
5	2	Screw–Hex Flange, M8 x 1.25 x 16 mm	7517956
6	2	Screw–Hex Flange, M12 x 1.75 x 30 mm	7520054

REF	QTY	PART DESCRIPTION	P/N AVAILABLE SEPARATELY
7	2	Screw–Hex Flange, M8 x 1.25 x 20 mm	7518555
8	1	Cable Tie, Driver Harness (not shown)	n/a

REAR HARNESS

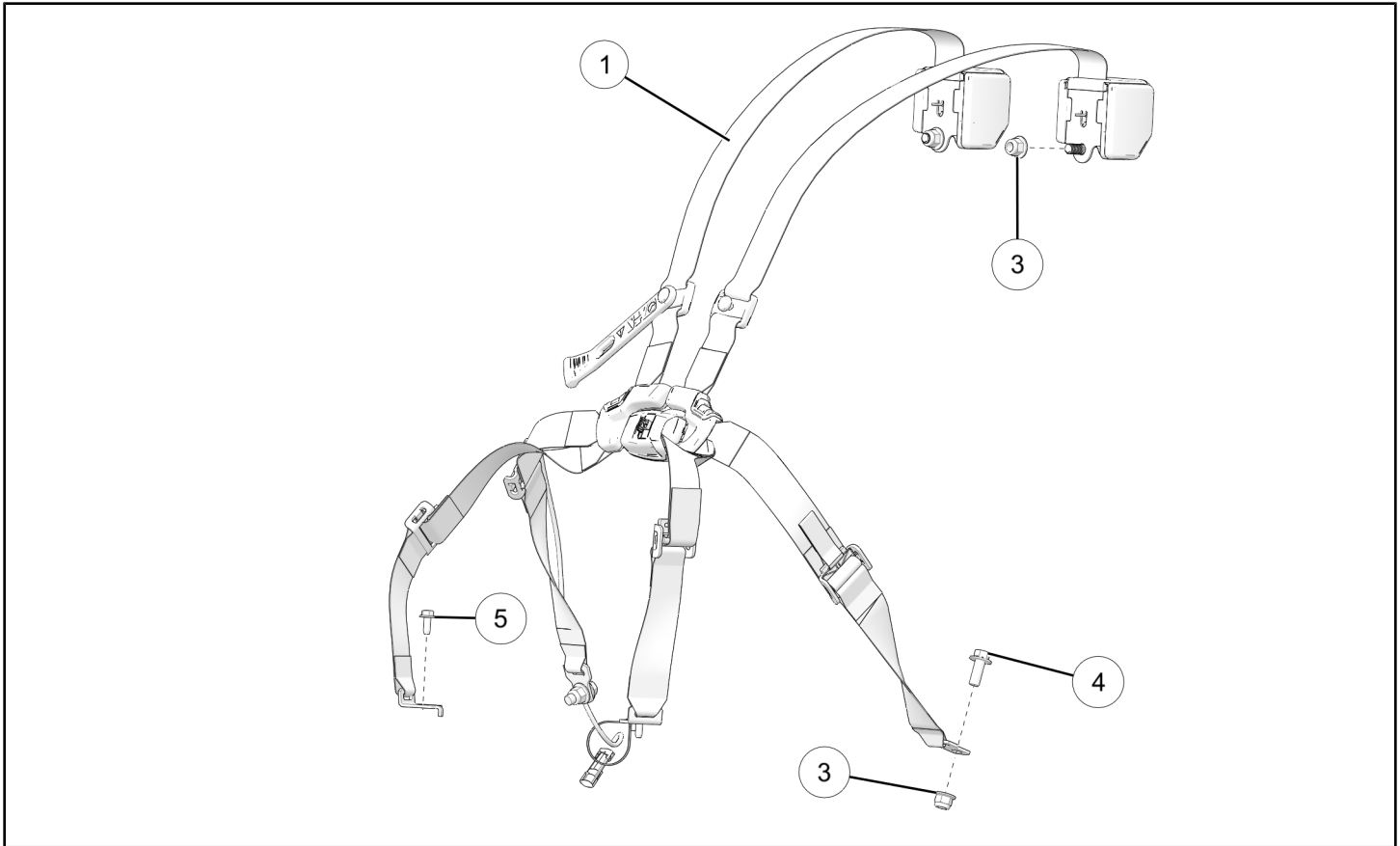

REF	QTY	PART DESCRIPTION	P/N AVAILABLE SEPARATELY
1	1	Assembly–Seat Belt Harness, Rear, Right-Hand Assembly–Seat Belt Harness, Rear, Left-Hand	2639181 2639184
2	n/a	Not Used	n/a
3	4	Nut–Hex Flange, Nylon Locking, M12 x 1.75 mm	7547441
4	2	Screw–Hex Flange, M12 x 1.75 x 30 mm	7520054
5	2	Screw–Hex Flange, M8 x 1.25 x 20 mm	7518555

TOOLS REQUIRED

- Safety Glasses
- Pliers, Push Pin Rivet
- Socket Set, Metric
- Socket Set, Torx® Bit
- Torque Wrench
- Wrench Set, Metric

IMPORTANT

Your Multi-Point Harness Kit is exclusively designed for your vehicle. Please read the installation instructions thoroughly before beginning. Installation is easier if the vehicle is clean and free of debris. For your safety, and to ensure a satisfactory installation, perform all installation steps correctly in the sequence shown.

INSTALLATION INSTRUCTIONS

[Two Passenger Vehicles](#), page 4

[Multi-Passenger Vehicles](#), page 9

TWO PASSENGER VEHICLES

VEHICLE PREPARATION

GENERAL

1. Park vehicle on a flat surface.
2. Shift vehicle into PARK.
3. Turn key to OFF position and remove key.

SEAT REMOVAL

1. Pull strap to disengage seat. Tilt seat forward and remove from vehicle.

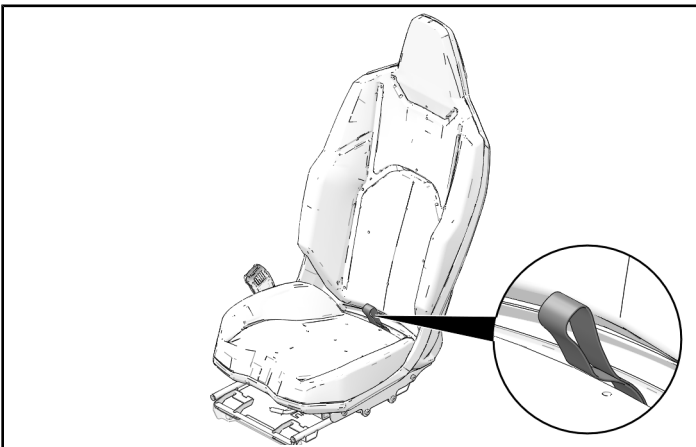

WHEEL WELL SHIELD REMOVAL

1. Remove and keep two push-pin rivets.

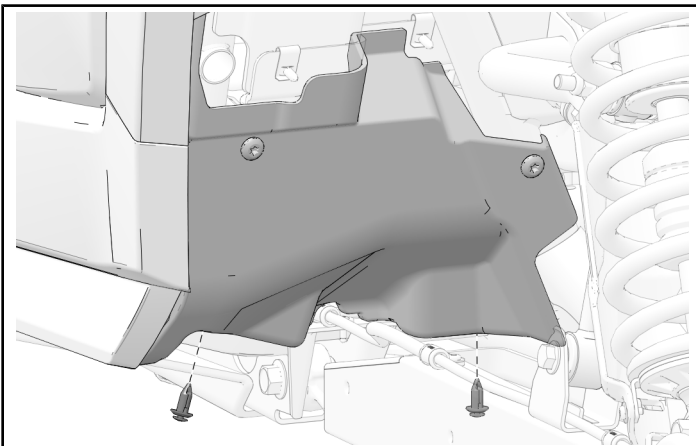

2. Remove and keep two screws.

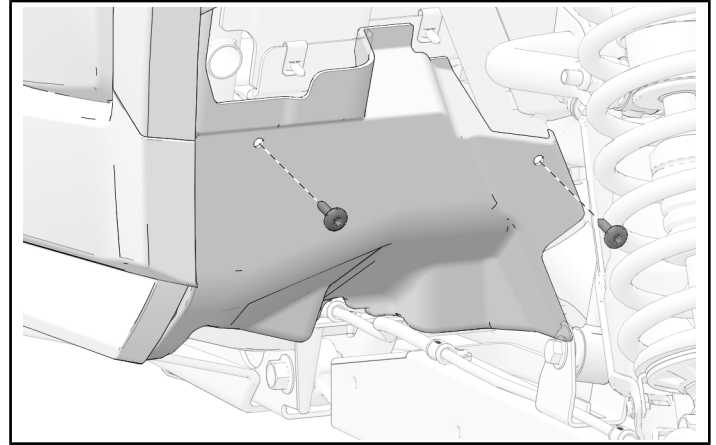

3. Remove wheel well shield from vehicle.

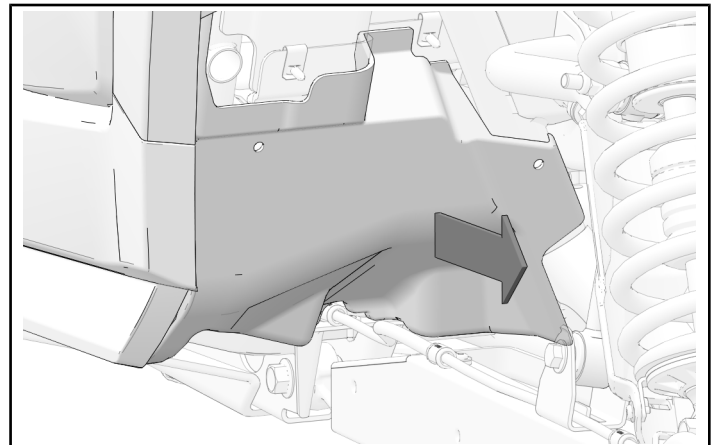

3-POINT HARNESS REMOVAL

NOTICE

Driver side shown; passenger side similar.

1. Counter-hold nut and remove one bolt from retractor. Discard hardware.

TIP

Nut can be accessed from wheel well.

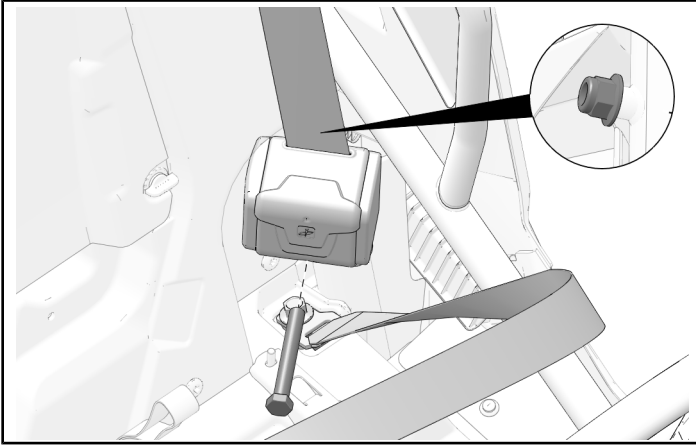

2. Counter-hold nut and remove one bolt holding lower mounting bracket. Discard hardware.

TIP

Nut can be accessed from wheel well.

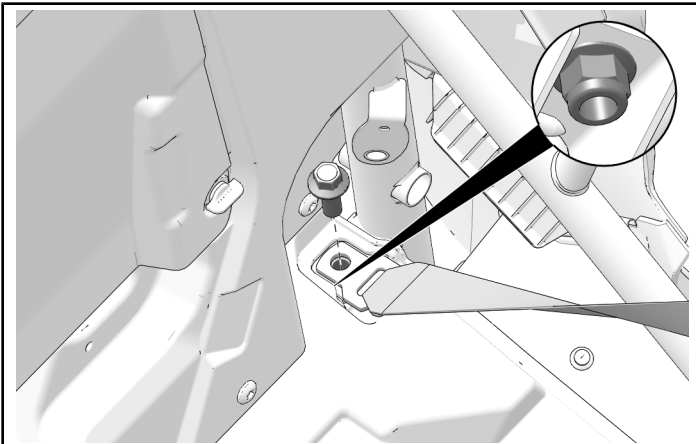

3. Remove and discard one bolt, one washer, and one nut holding harness guide.

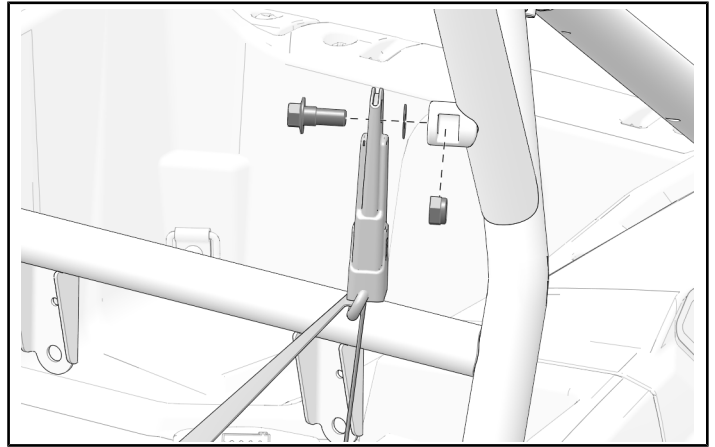

4. Remove and discard 3-point harness from vehicle.
5. Driver Side Only: Gently lift clip on connector and disconnect seat belt switch harness.

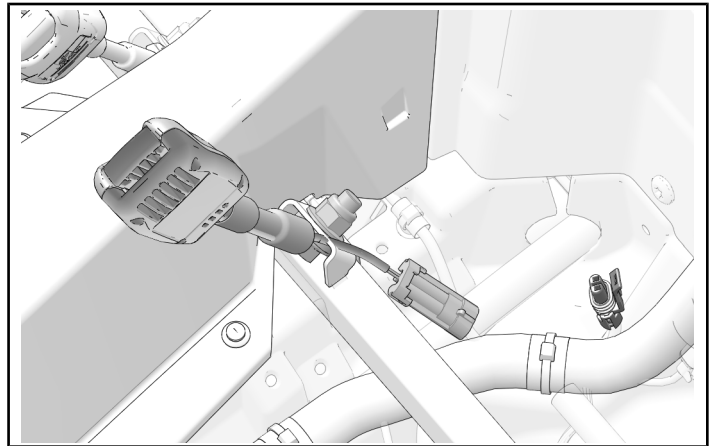

6. Counter-hold nut and remove one bolt to remove buckle assembly from vehicle. Discard hardware and seat belt buckle.

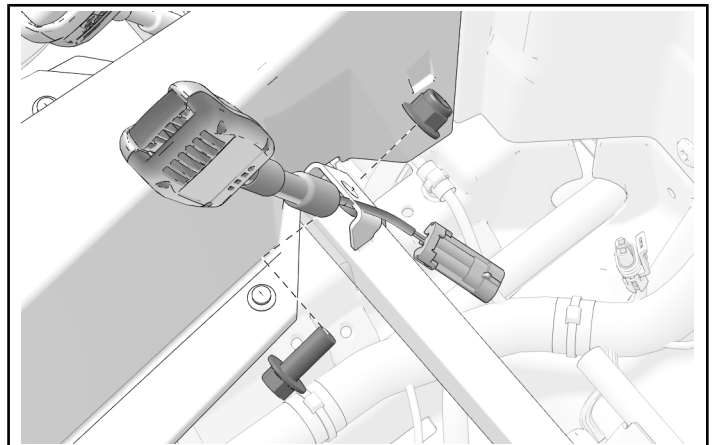

ACCESSORY INSTALLATION

NOTICE

Driver harness shown; passenger harness similar, except where noted.

1. Put multi-point harness ① in the vehicle.

IMPORTANT

Make sure shoulder straps are straight and not twisted during installation.

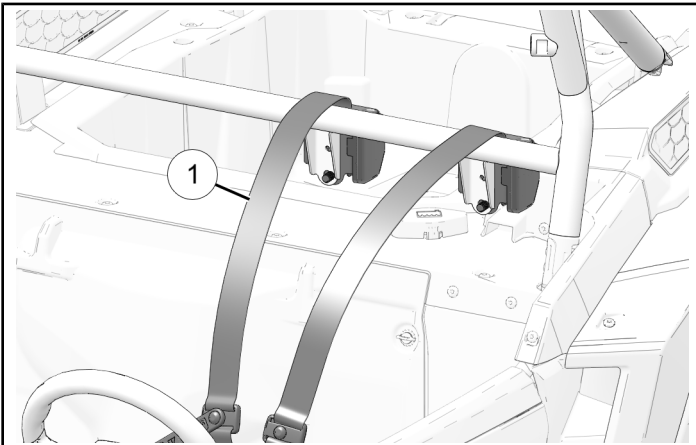

2. Install retractors with two bolts ② and two nuts ③. Counter-hold nuts and torque two bolts to specification.

TORQUE

Retractor Bolts:
44 ft-lbs (60 N·m)

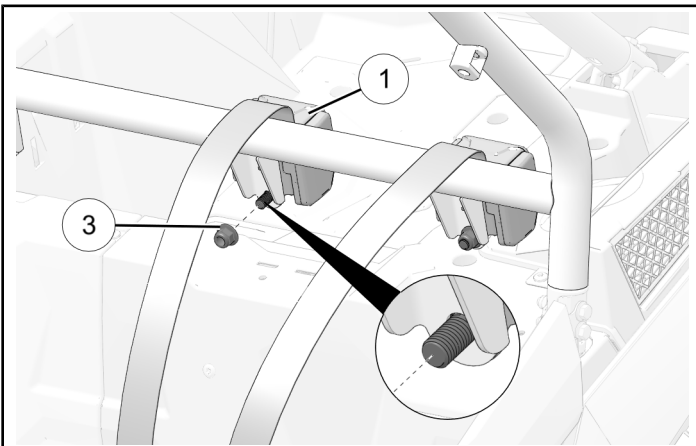

3. Install outside mounting position with one bolt ④ and one nut ③. Counter-hold nut and torque bolt to specification.

TORQUE

Side Mounting Bolt ④:
44 ft-lbs (60 N·m)

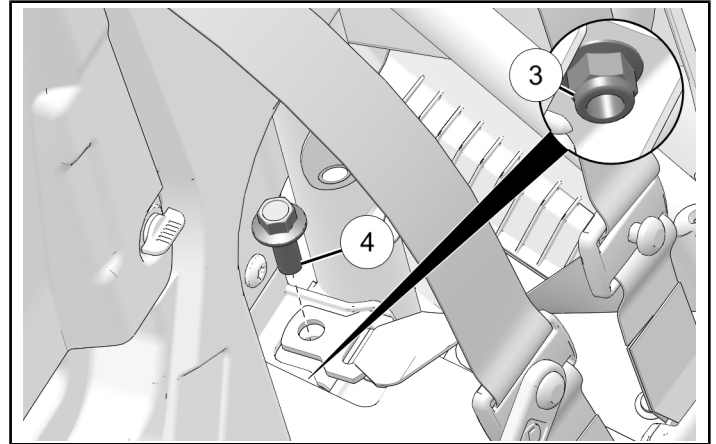

4. Install inside mounting position with one bolt ④ and one nut ③. Counter-hold nut and torque bolt to specification.

TORQUE

Side Mounting Bolt ④:
44 ft-lbs (60 N·m)

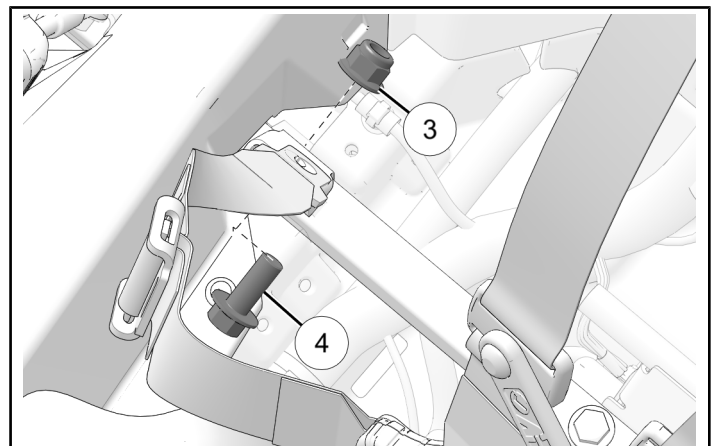

5. Driver Side Only: Connect seat belt switch harness to main vehicle harness.

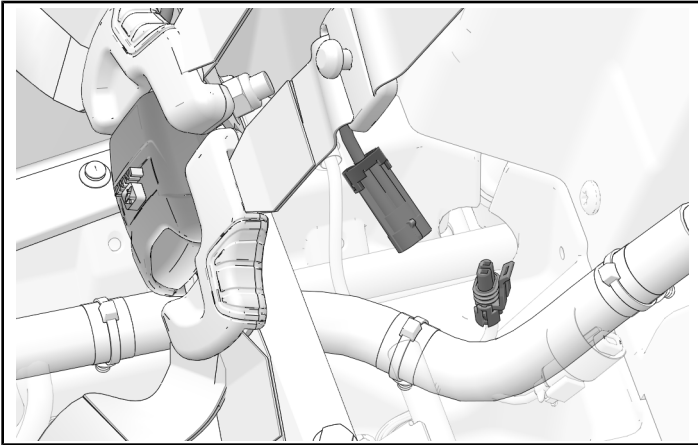

6. Install front mounting positions with two bolts ⑤. Torque bolts to specification.

TORQUE

Front Mounting Bolts ⑤:
13 ft-lbs (18 N·m)

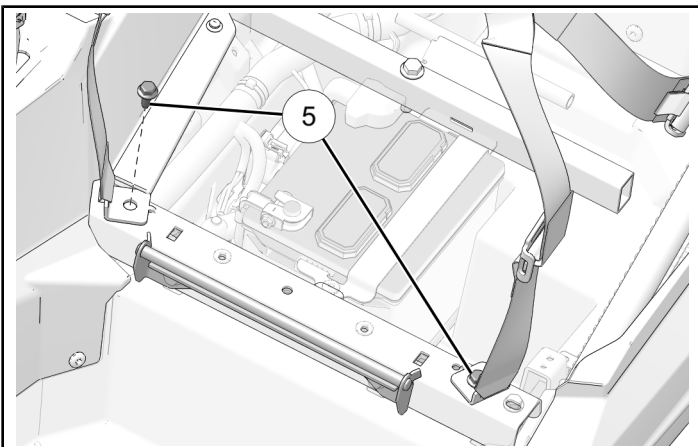

VEHICLE REASSEMBLY

SEAT INSTALLATION

1. Put seat in vehicle with front resting on tube, as shown. Push seat back until it engages with rear tube.

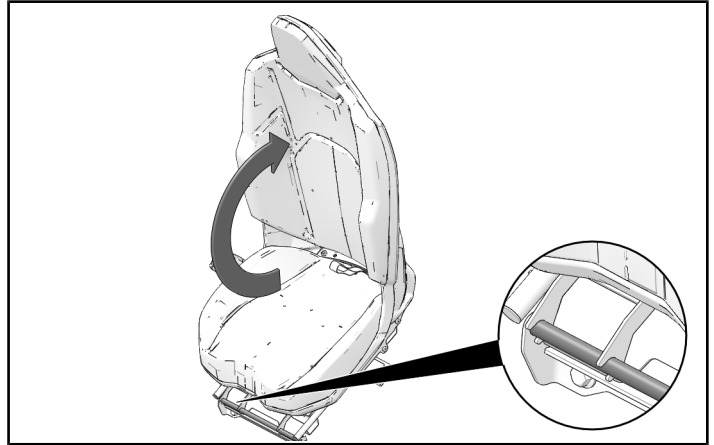

WHEEL WELL SHIELD INSTALLATION

1. Put wheel well shield in installed position.

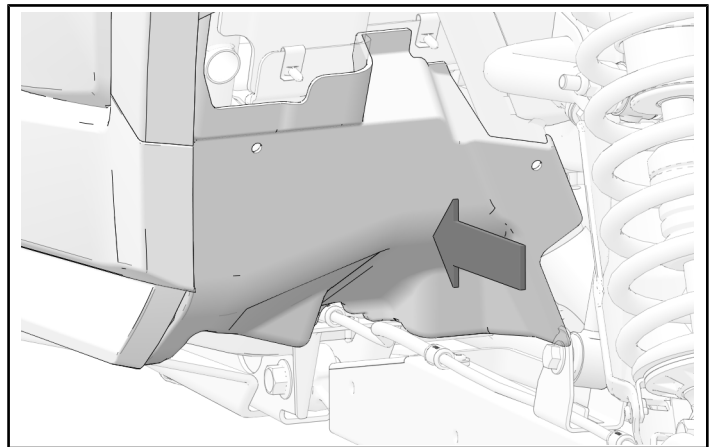

2. Install top of shield with two retained screws.

Do not torque screws at this time.

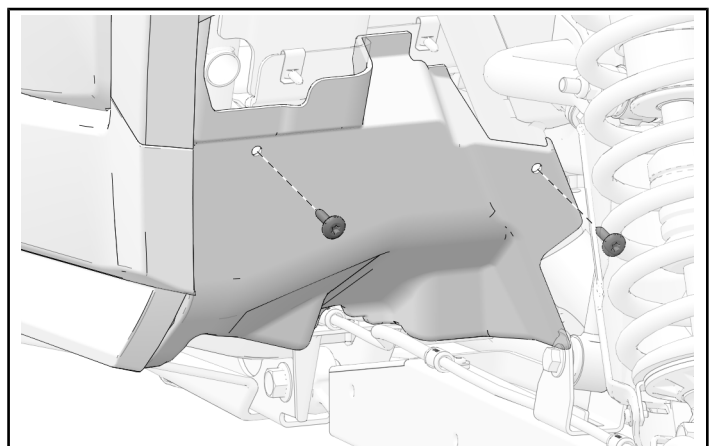

3. Install bottom of shield with two retained push-pin rivets.

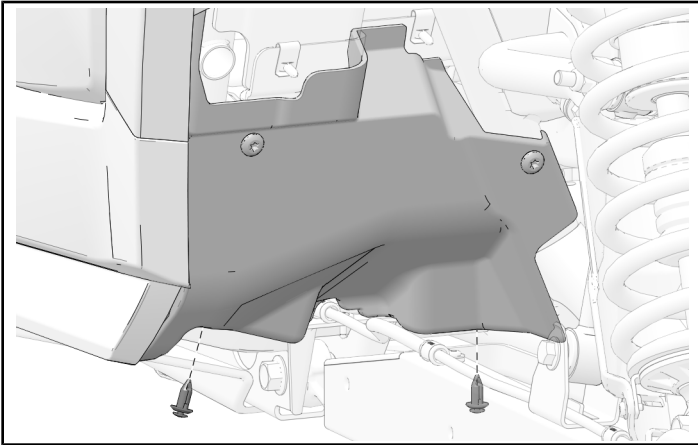

4. Torque two screws to specification.

TORQUE

Wheel Well Shield Screws:
9 ft-lbs (12 N·m)

MUTLI-PASSENGER VEHICLES

VEHICLE PREPARATION

GENERAL

1. Park vehicle on a flat surface.
2. Shift vehicle into PARK.
3. Turn key to OFF position and remove key.

SEAT REMOVAL

1. Pull strap to disengage seat. Tilt seat forward and remove from vehicle.

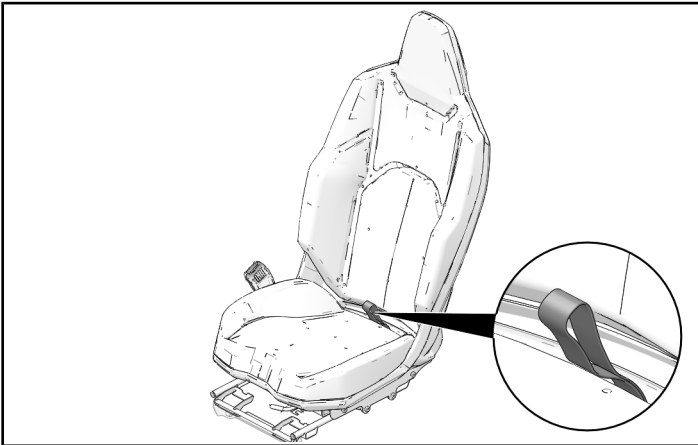

FRONT CENTER CONSOLE REMOVAL

1. Remove and keep shifter cover.

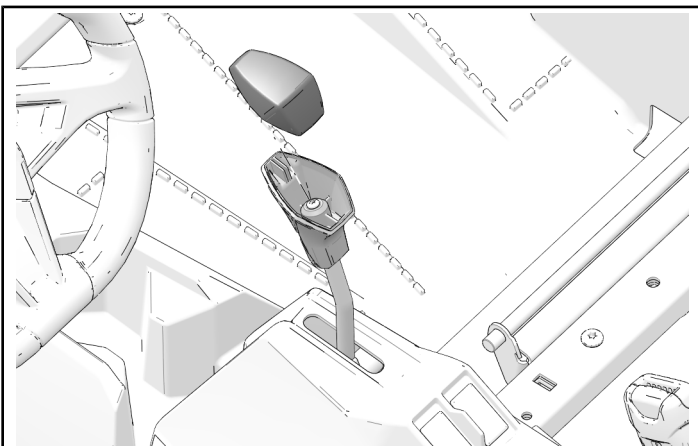

2. Remove and keep one fastener from shifter handle.

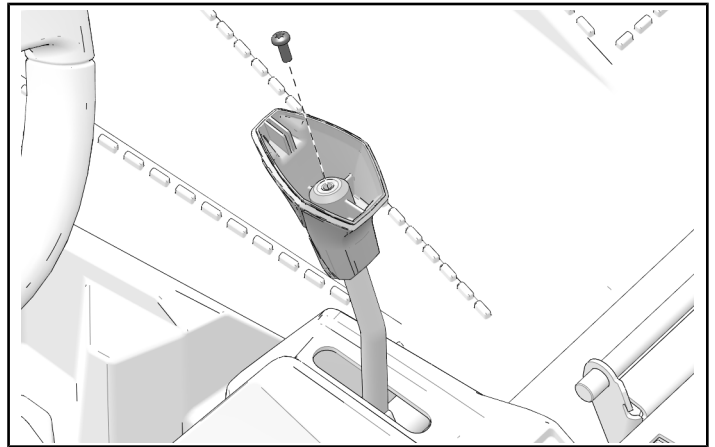

3. Remove and keep shifter handle.

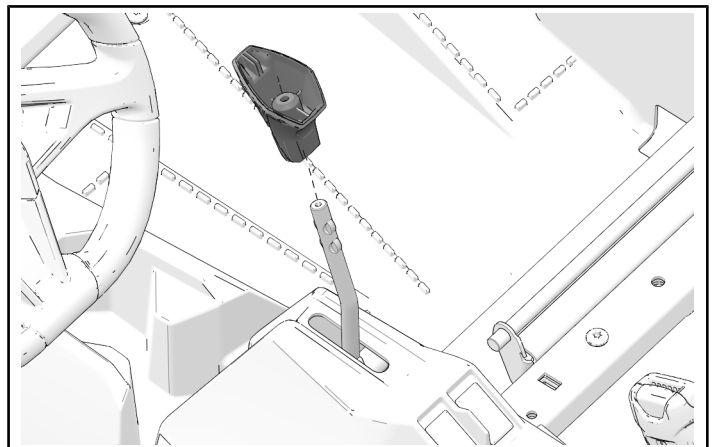

4. Remove four fasteners from the left-side of the center console.

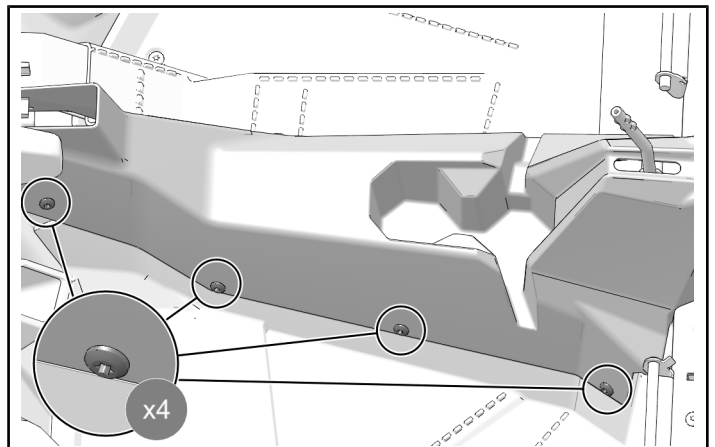

5. Remove three push-pin rivets from the rear of the center console.

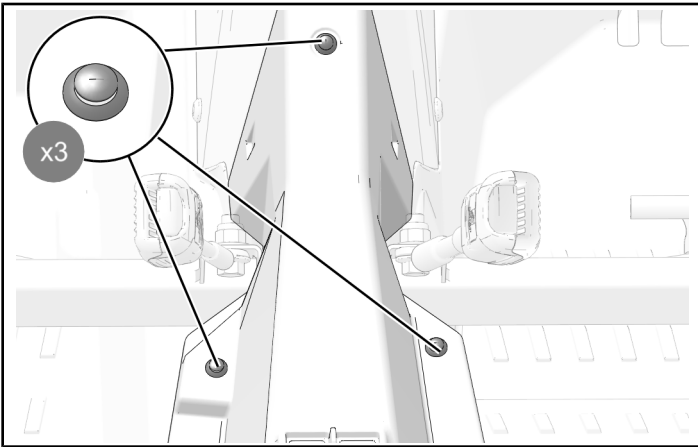

6. Remove three fasteners from the right-side of the center console.

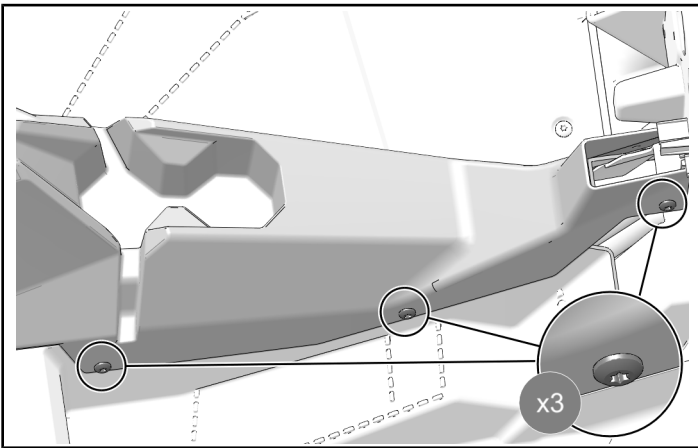

7. Remove center console from vehicle.

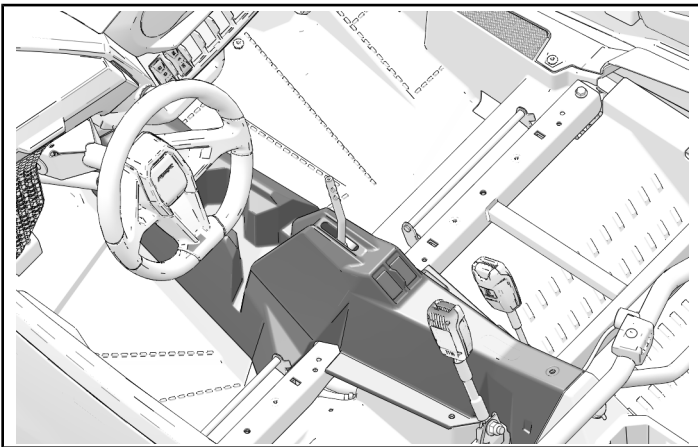

WHEEL WELL SHIELD REMOVAL

1. Remove and keep two push-pin rivets.

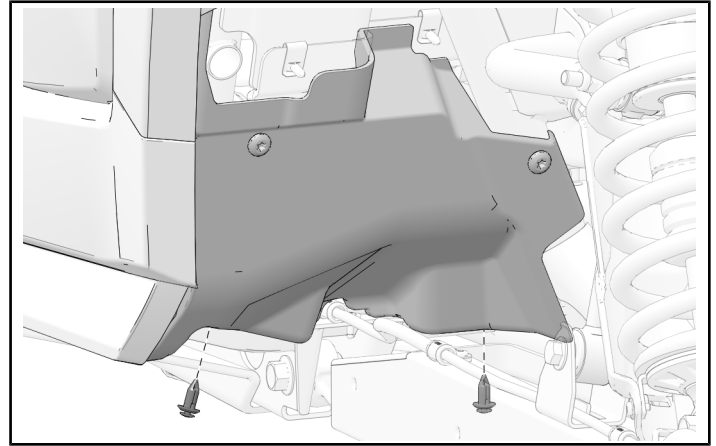

2. Remove and keep two screws.

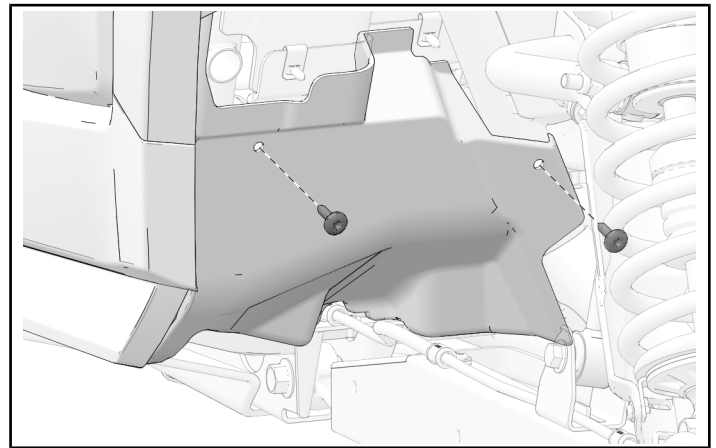

3. Remove wheel well shield from vehicle.

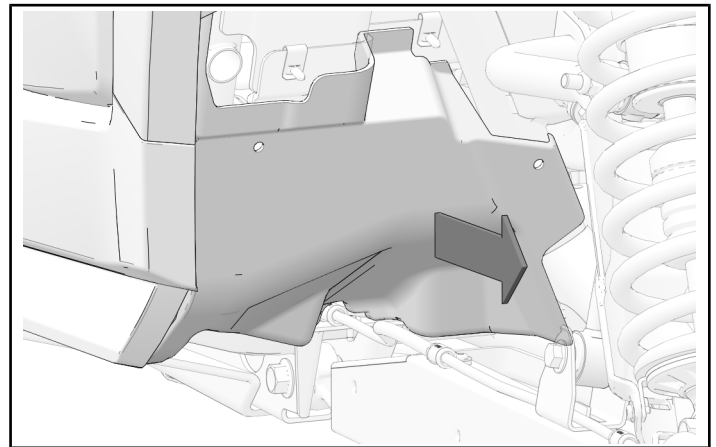

3-POINT HARNESS REMOVAL

NOTICE

Driver side shown; passenger side similar.

1. Remove one nut from retractor assembly.

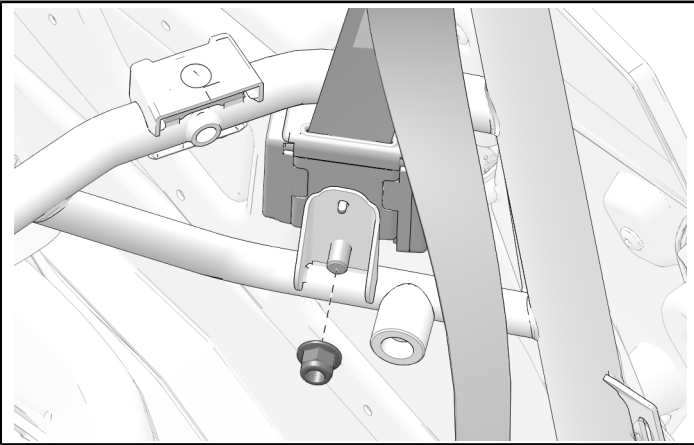

2. Counter-hold nut and remove one bolt from lower mounting position.

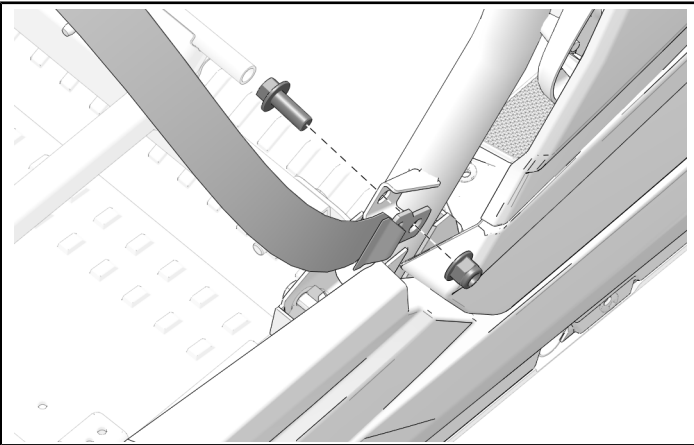

3. Remove and discard one bolt, one washer, and one nut holding harness guide.

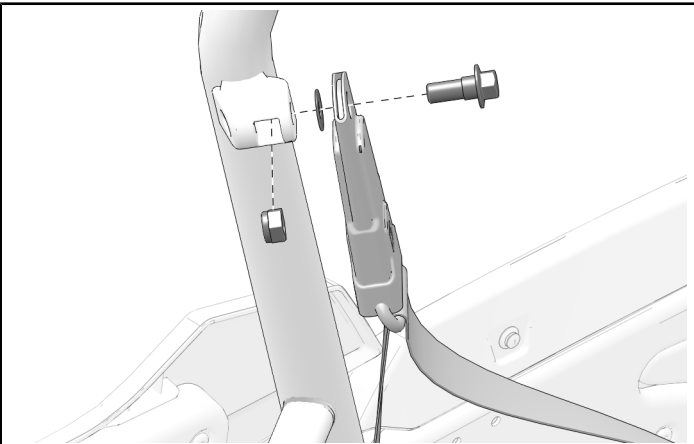

4. Remove and discard 3-point harness from vehicle.

5. Driver Side Only: Gently lift clip on connector and disconnect seat belt switch harness.

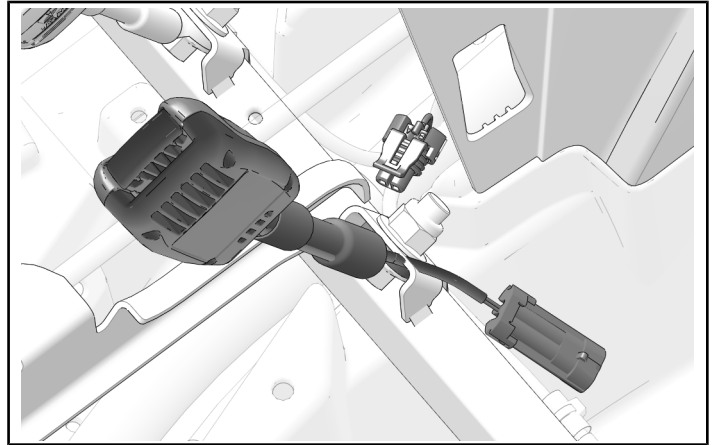

6. Counter-hold nut and remove one bolt to remove buckle assembly from vehicle. Discard hardware and seat belt buckle.

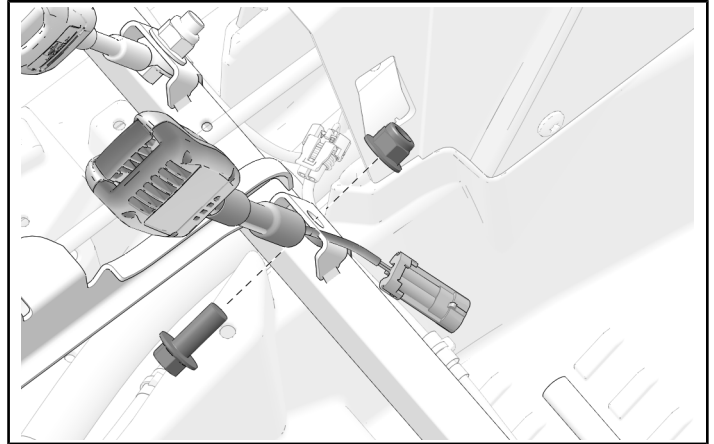

REAR 3-POINT HARNESS REMOVAL

1. Counter-hold nut and remove one bolt from retractor. Discard hardware.

TIP

Nut can be accessed from wheel well.

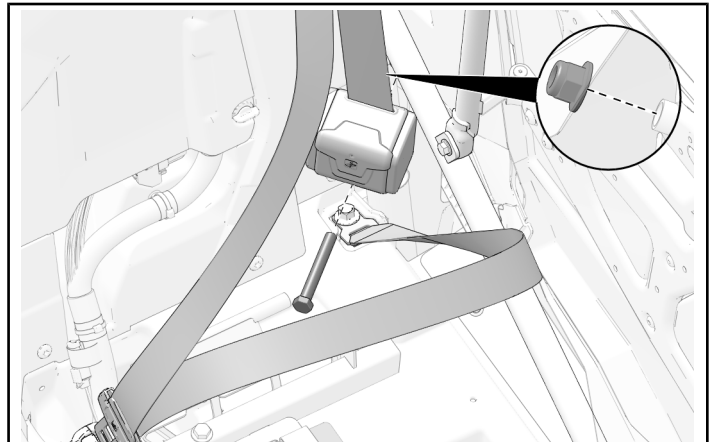

- Counter-hold nut and remove one bolt holding lower mounting bracket. Discard hardware.

TIP

Nut can be accessed from wheel well.

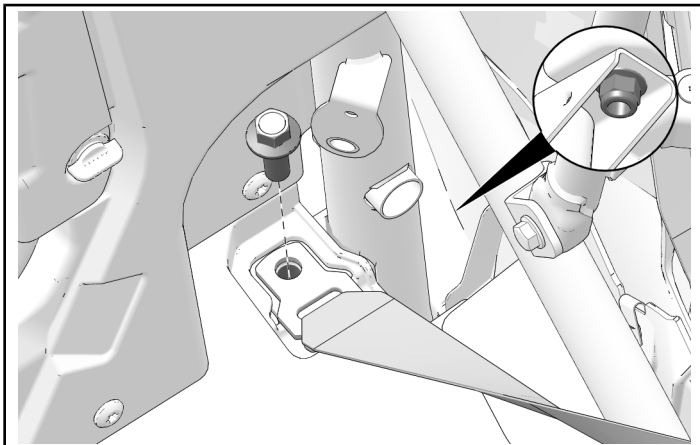

- Remove and discard one bolt, one washer, and one nut holding harness guide.

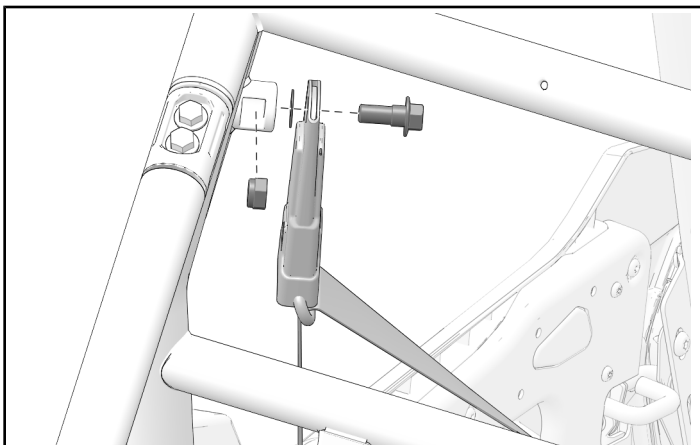

- Remove and discard 3-point harness from vehicle.
- Counter-hold nut and remove one bolt to remove buckle assembly from vehicle. Discard hardware and seat belt buckle.

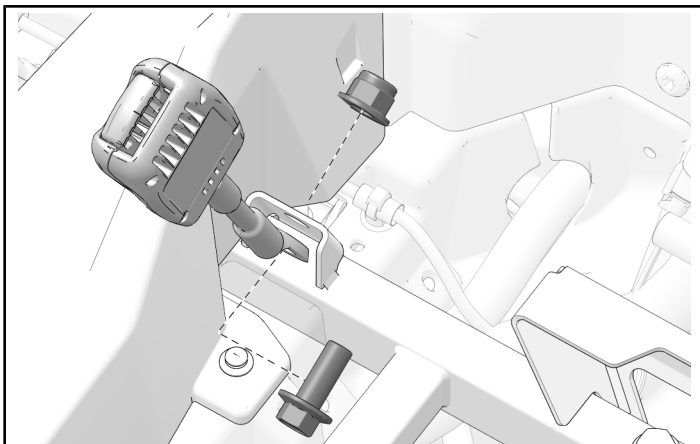

ACCESSORY INSTALLATION

FRONT HARNESS INSTALLATION

NOTICE

Driver harness shown; passenger harness similar, except where noted.

- Install two harness guides ④ with one bolt ⑤ per guide. Torque two bolts to specification.

TORQUE

Harness Guide Bolts ⑤:
13 ft-lbs (18 N·m)

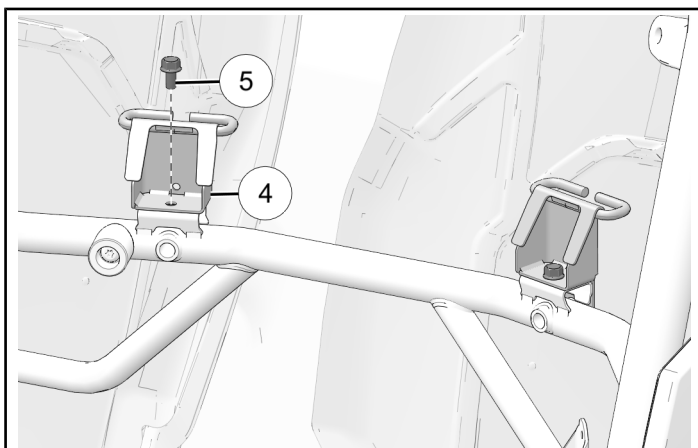

- Put multi-point harness ① in the vehicle.

IMPORTANT

Make sure shoulder straps are straight and not twisted during installation.

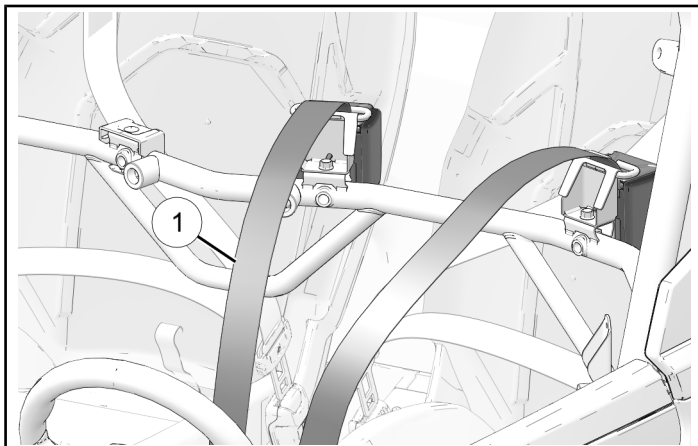

- Put alignment tab in harness guide and put shoulder straps in guides, as shown.

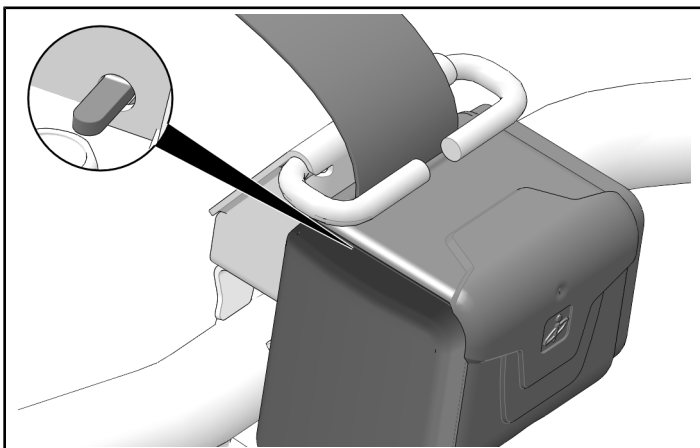

- Install retractors with two bolts ② and two nuts ③. Counter-hold nuts and torque two bolts to specification.

TORQUE

Retractor Bolts:
44 ft-lbs (60 N·m)

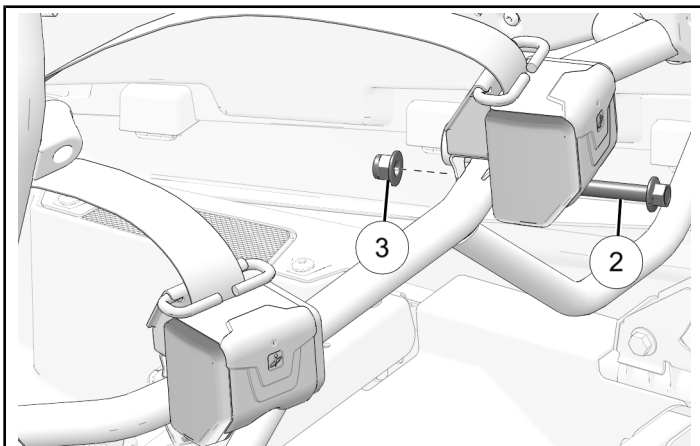

- Install outside mounting position with one bolt ⑥ and one nut ③. Counter-hold nut and torque bolt to specification.

TORQUE

Side Mounting Bolt ⑥:
44 ft-lbs (60 N·m)

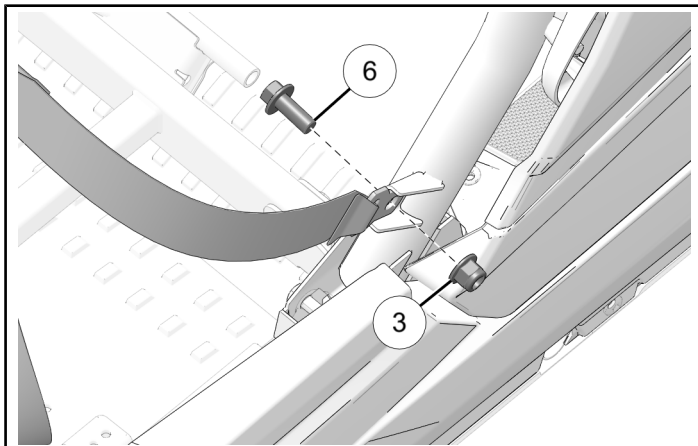

- Install inside mounting position with one bolt ⑥ and one nut ③. Counter-hold nut and torque bolt to specification.

TORQUE

Side Mounting Bolt ⑥:
44 ft-lbs (60 N·m)

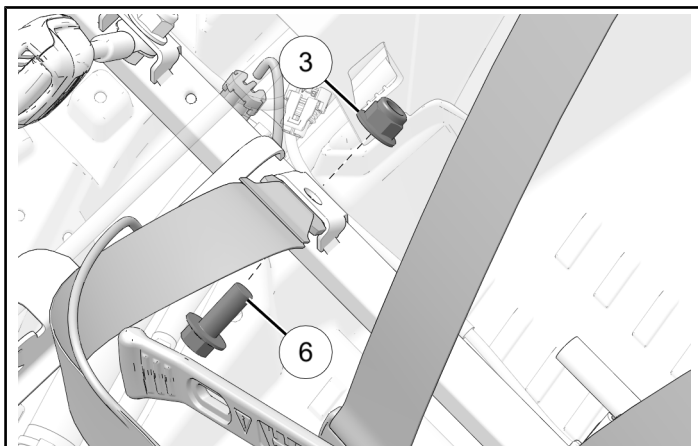

7. Driver Side Only: Connect seat belt switch harness to main vehicle harness.

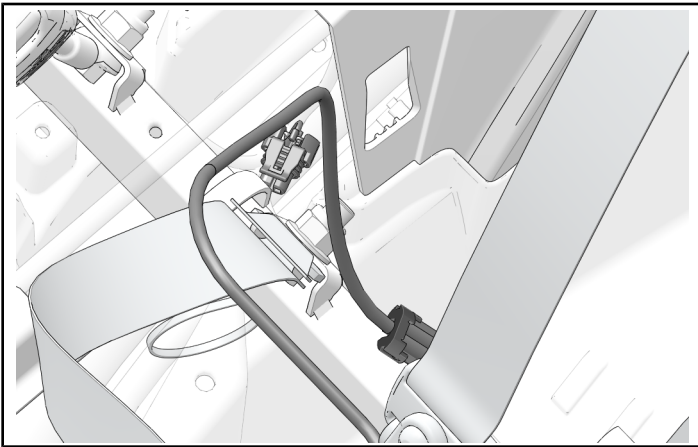

8. Install front mounting positions with two bolts ⑦. Torque bolts to specification.

TORQUE

Front Mounting Bolts ⑦:
13 ft-lbs (18 N·m)

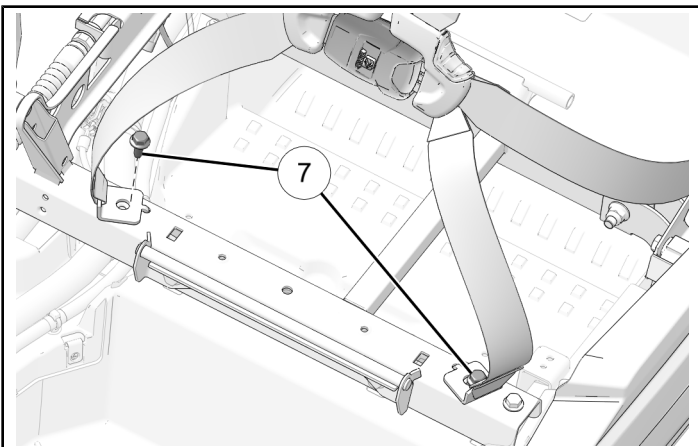

REAR HARNESS INSTALLATION

1. Put multi-point harness ① in the vehicle.

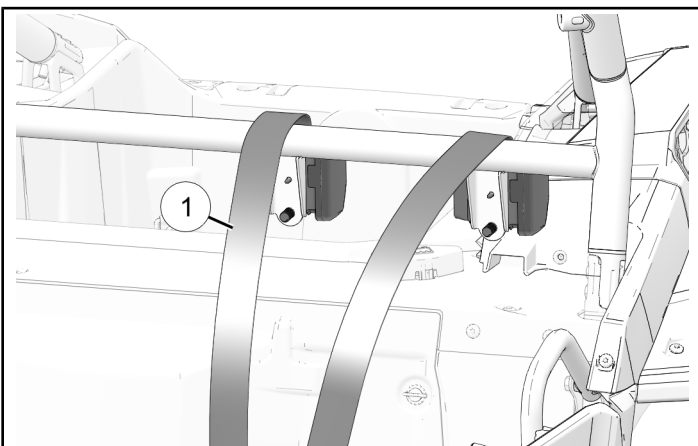

2. Install retractors with two bolts ② and two nuts ③. Counter-hold nuts and torque two bolts to specification.

TORQUE

Retractor Bolts:
44 ft-lbs (60 N·m)

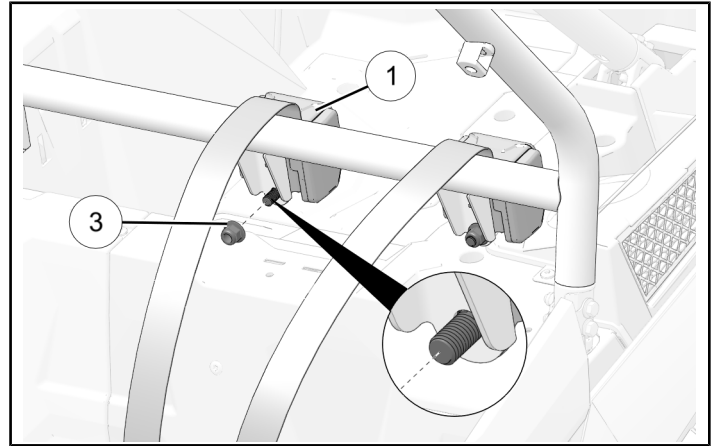

3. Install outside mounting position with one bolt ④ and one nut ③. Counter-hold nut and torque bolt to specification.

TORQUE

Side Mounting Bolt ④:
44 ft-lbs (60 N·m)

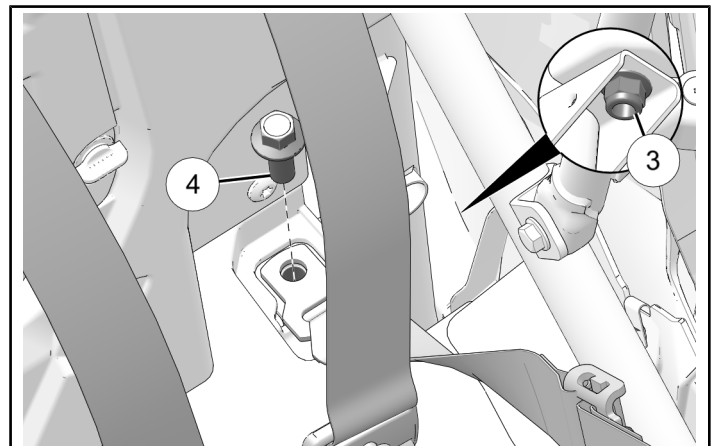

4. Install inside mounting position with one bolt ④ and one nut ③. Counter-hold nut and torque bolt to specification.

TORQUE

Side Mounting Bolt ④:
44 ft-lbs (60 N·m)

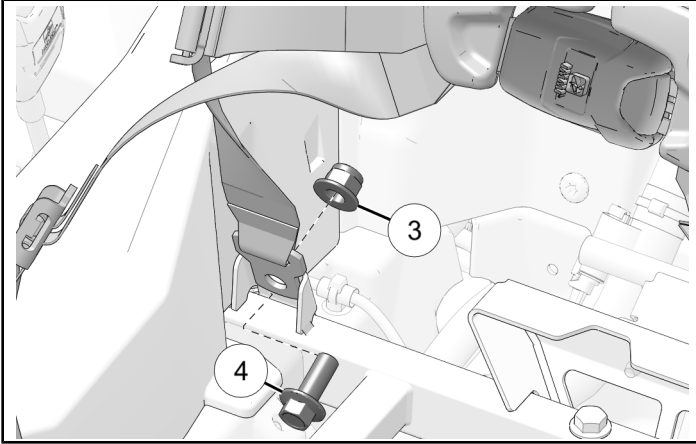

5. Install front mounting positions with two bolts ⑤. Torque bolts to specification.

TORQUE

Front Mounting Bolts ⑤:
13 ft-lbs (18 N·m)

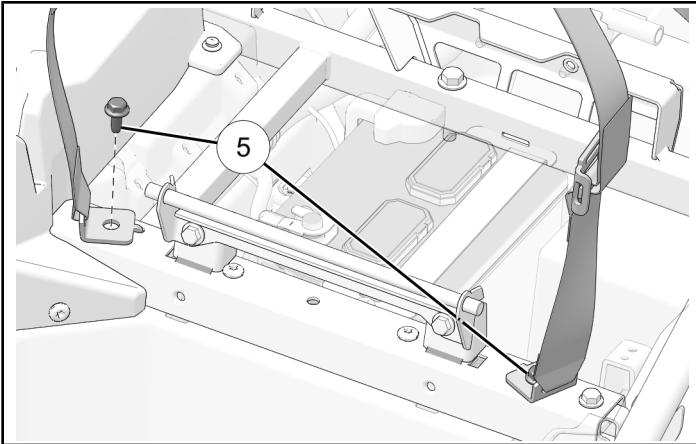

VEHICLE REASSEMBLY

FRONT CENTER CONSOLE INSTALLATION

1. Put center console into vehicle and over shifter.

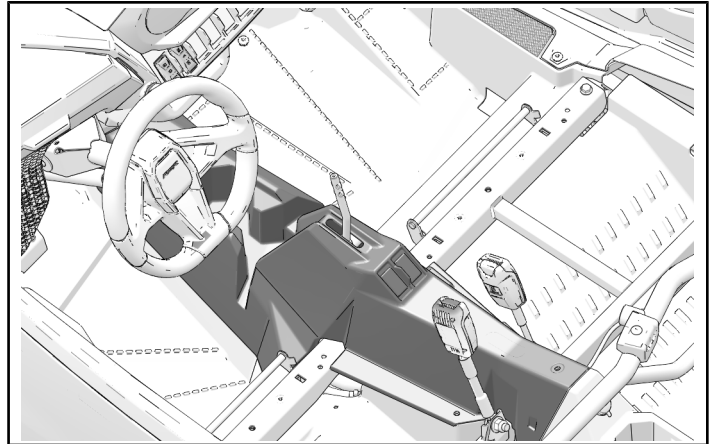

2. Install passenger side of center console with three retained fasteners.

Do not torque fasteners at this time.

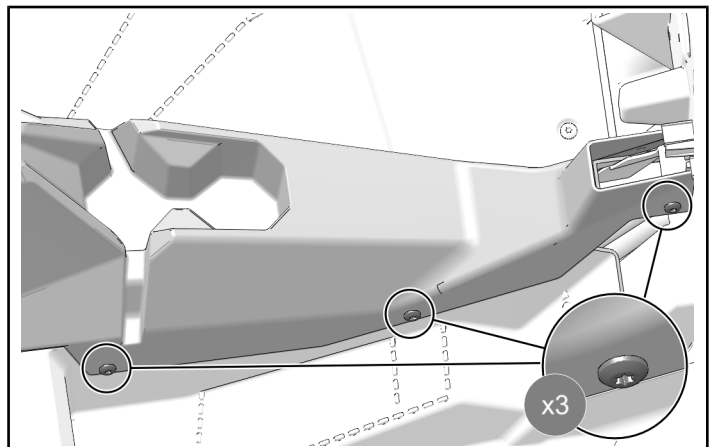

3. Install rear of center console with three retained push-pin rivets.

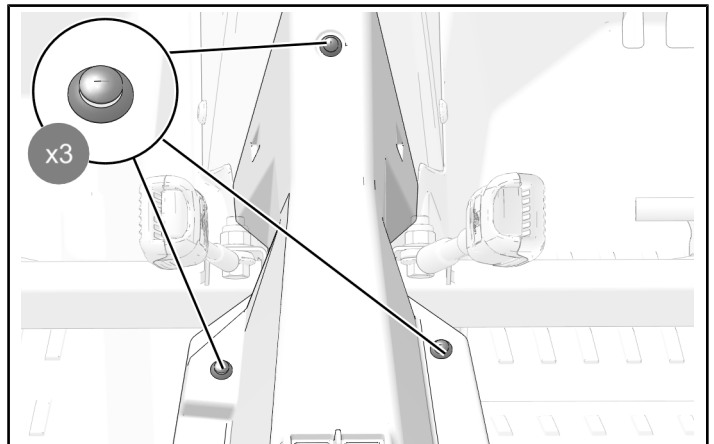

4. Install passenger side of center console with four retained fasteners.

Do not torque fasteners at this time.

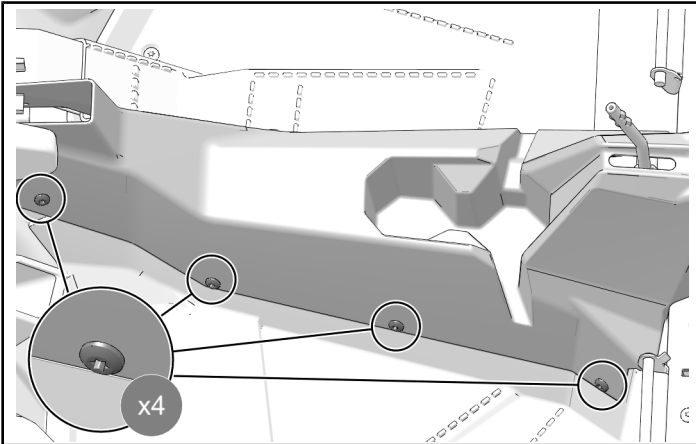

5. Torque all center console fasteners to specification.

TORQUE

Center Console Fasteners:
88 in-lbs (10 N·m)

6. Put shifter handle onto shifter post.

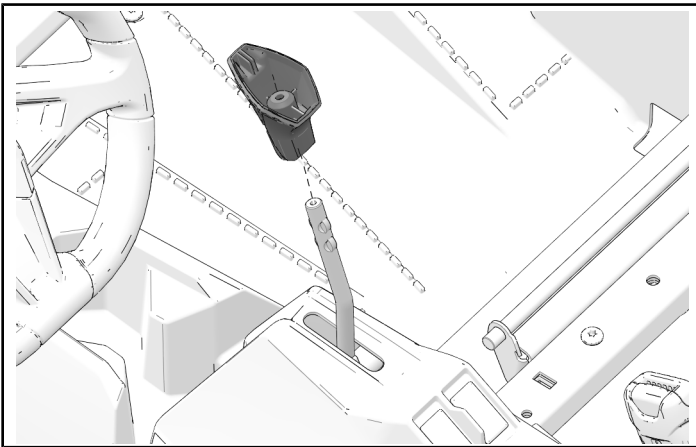

7. Install shifter handle with one retained fastener. Torque fastener to specification

TORQUE

Shifter Handle Fastener:
35 in-lbs (4 N·m)

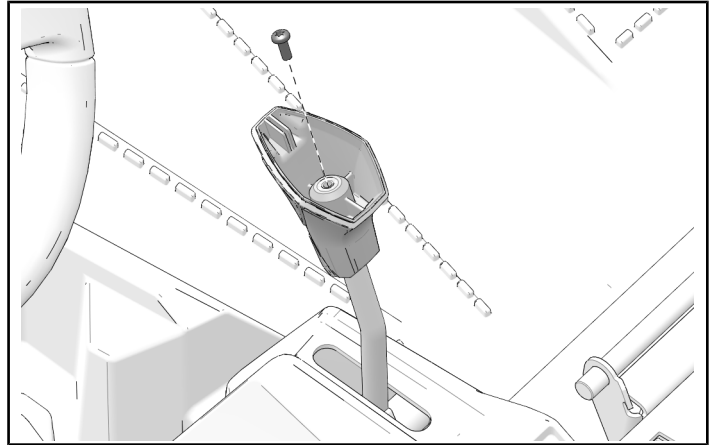

8. Install shifter cover.

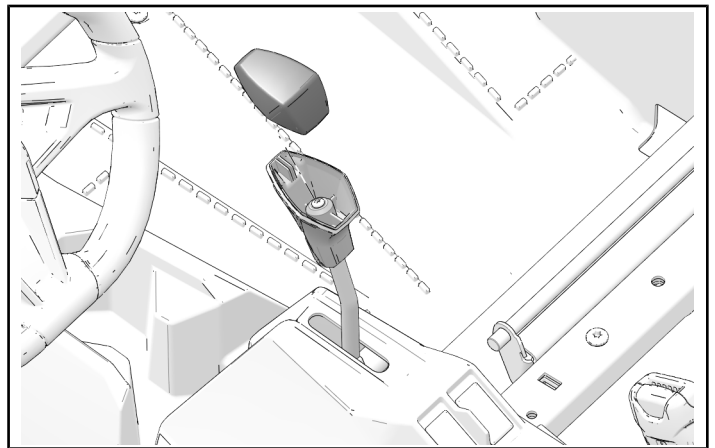

SEAT INSTALLATION

1. Put seat in vehicle with front resting on tube, as shown. Push seat back until it engages with rear tube.

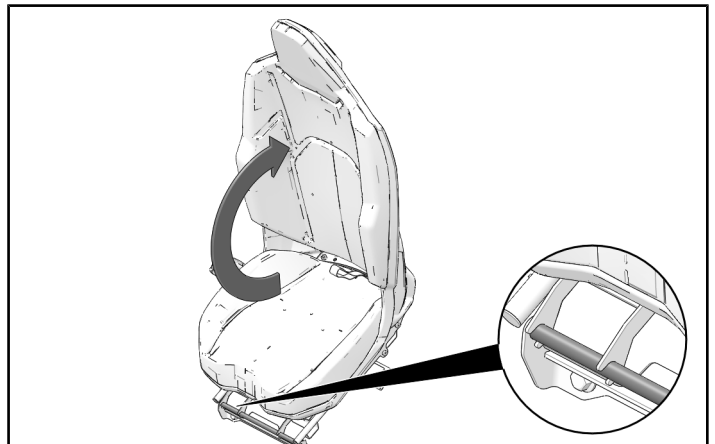

WHEEL WELL SHIELD INSTALLATION

1. Put wheel well shield in installed position.

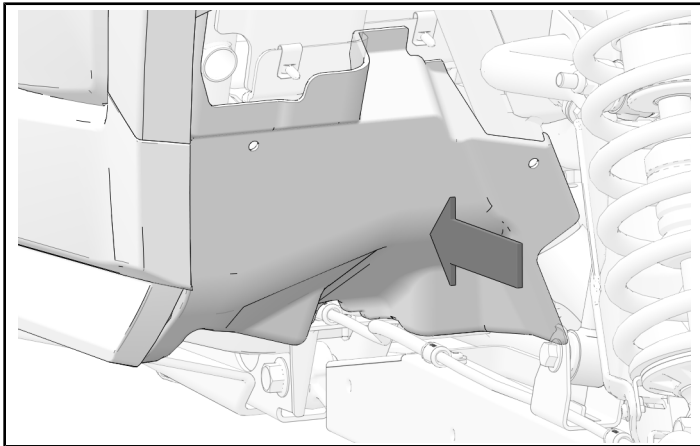

2. Install top of shield with two retained screws.

Do not torque screws at this time.

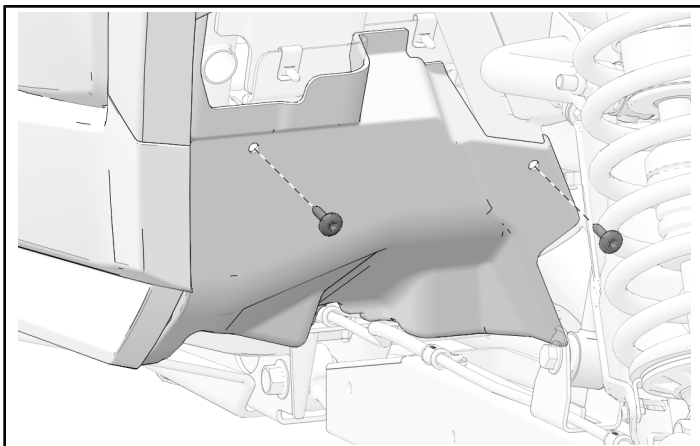

3. Install bottom of shield with two retained push-pin rivets.

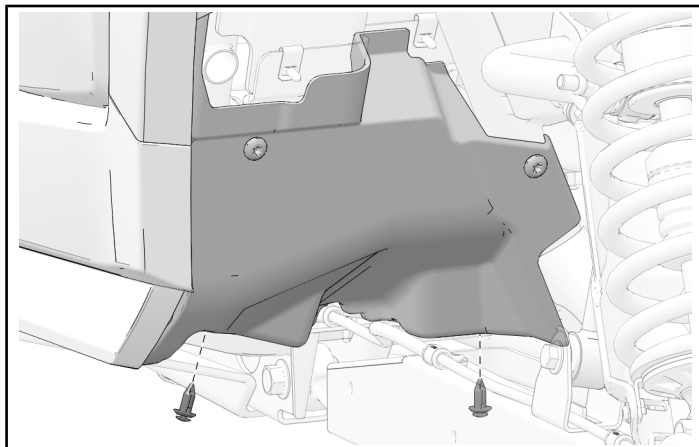

4. Torque two screws to specification.

TORQUE

Wheel Well Shield Screws:
9 ft-lbs (12 N·m)