

BODY ARMOR KIT



P/N 2884851

BEFORE YOU BEGIN

Read these instructions and check to be sure all parts and tools are accounted for. Please retain these installation instructions for future reference and parts ordering information.

APPLICATION

REQUIRED SOLD SEPARATELY

Only parts for installation of the Body Armor Kit are included. Prior installation of one of the following additional kits is also required (sold separately):

- *Front Bumper Kit, HD*, (P/N 2884850)
- *Front Bumper Kit, Trail*, (P/N 2884844)
- *Front Bumper Kit, Utility*, (P/N 2884810)

KIT CONTENTS

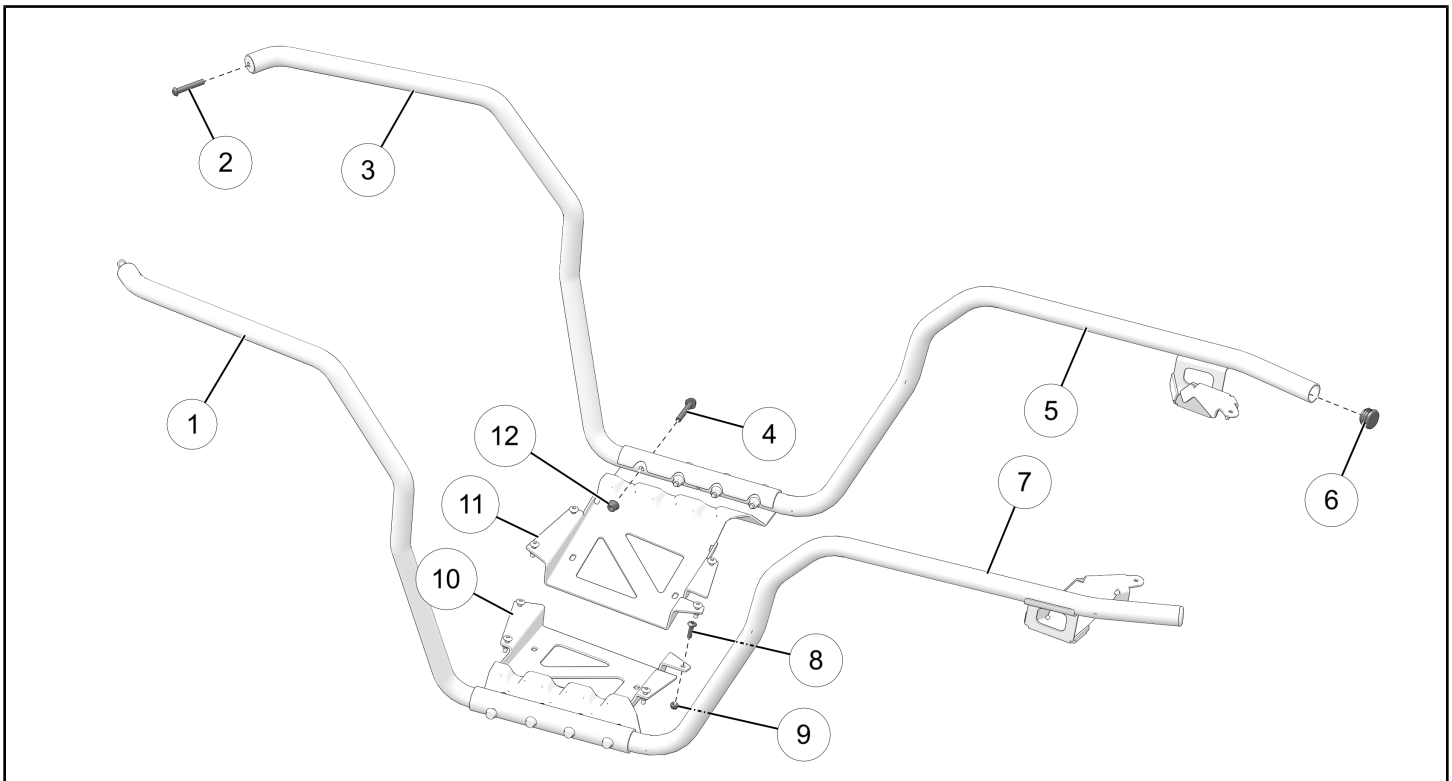

REF	QTY	PART DESCRIPTION	P/N AVAILABLE SEPARATELY	AVAILABLE SERVICE KIT
1	1	Weld-Front, Side Guard, LH	1026084	n/a
2	2	Screw-Socket Head, M8 x 1.25 x 50	7518013	n/a
3	1	Weld-Front, Side Guard, RH	1026085	n/a
4	8	Screw-Hex Flange, M8 x 1.25 x 50	n/a	2208770
5	1	Weld-Rear, Side Guard, RH	1026083	n/a

REF	QTY	PART DESCRIPTION	P/N AVAILABLE SEPARATELY	AVAILABLE SERVICE KIT
6	2	Plug-End Cap, 1.25"	5450305	n/a
7	1	Weld-Rear, Side Guard, LH	1026082	n/a
8	8	Screw-Torx® Truss Head, 1/4-20 x 1	n/a	2208770
9	8	Nut-1/4-20, Nylon Locking	n/a	2208770
10	1	Bracket-Mount, LH	5270104	n/a
11	1	Bracket-Mount, RH	5270105	n/a
12	8	Nut-M8 x 1.25, Flange, Nylon Locking	n/a	2208770

TOOLS REQUIRED

- Safety Glasses
- Socket Set, Metric
- Socket Set, SAE
- Socket Set, Torx® Bit
- Torque Wrench
- Wrench Set, Hex Bit
- Wrench Set, Metric
- Wrench Set, SAE

IMPORTANT

Your Body Armor Kit is exclusively designed for your vehicle. Please read the installation instructions thoroughly before beginning. Installation is easier if the vehicle is clean and free of debris. For your safety, and to ensure a satisfactory installation, perform all installation steps correctly in the sequence shown.

INSTALLATION INSTRUCTIONS

VEHICLE PREPARATION

GENERAL

1. Park vehicle on a flat surface.
2. Push engine stop switch to the OFF position.
3. Turn key to the OFF position and remove key.

IMPORTANT

You must have one of the following kits already installed to complete the installation of the Body Armor Kit:

- *Front Bumper Kit, HD*, (P/N 2884850)
- *Front Bumper Kit, Trail*, (P/N 2884844)
- *Front Bumper Kit, Utility*, (P/N 2884810)

ACCESSORY INSTALLATION

1. Remove nuts from both sides of the underside of the rear rack tube support.

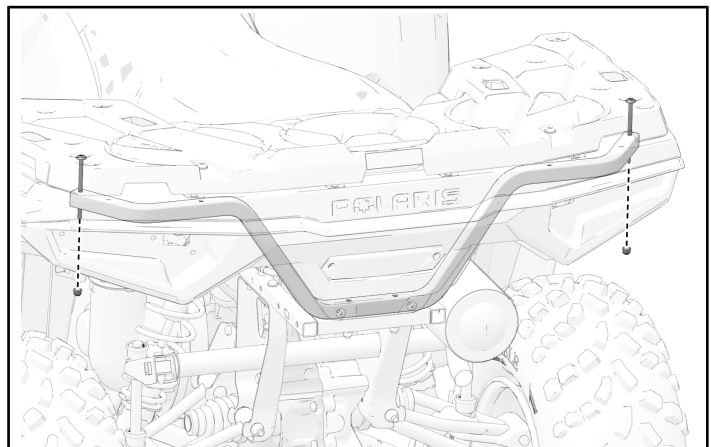

2. Remove and discard the four screws and nuts from the left footwell.

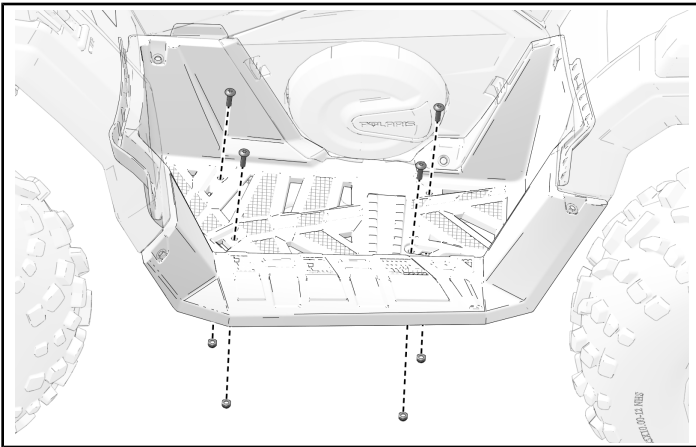

3. Install the left-hand bracket mount ⑩ onto the left footwell. Loosely install the two front footwell screws ⑧ and nuts ⑨ to hold the assembly into place.

IMPORTANT

Do not tighten the fasteners at this time.

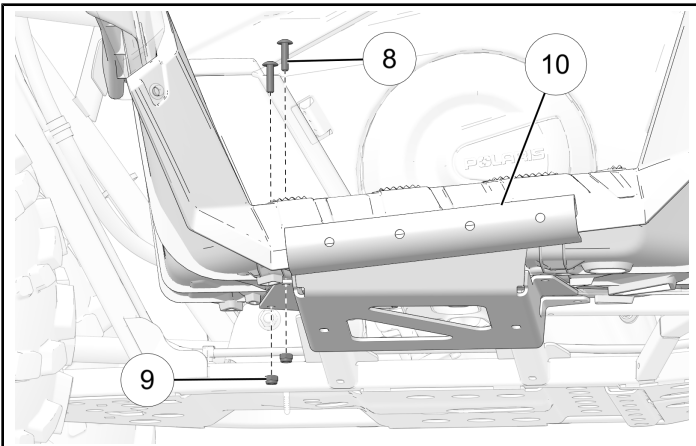

4. Slide the rear left-hand side guard weld ⑦ into the left-hand bracket mount ⑩ and lift the assembly into place.

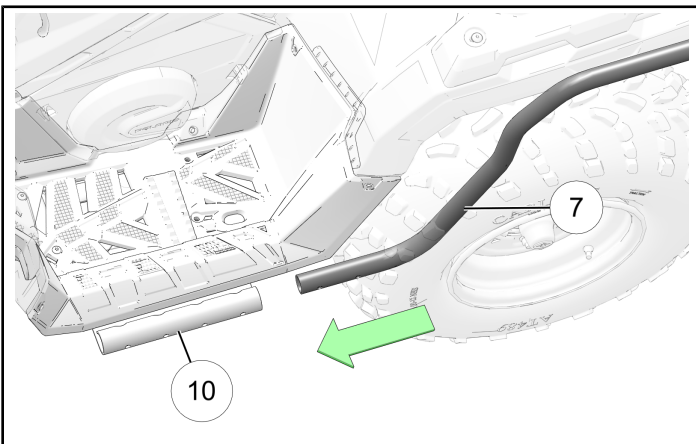

5. Align the bracket on the rear left-hand side guard weld ⑦ with the rear rack tube support. Loosely install the nut that was previously removed in step 1 to hold the bracket and the rear rack tube support into place.

IMPORTANT

Do not tighten the nut at this time.

NOTICE

Rear left side shown.

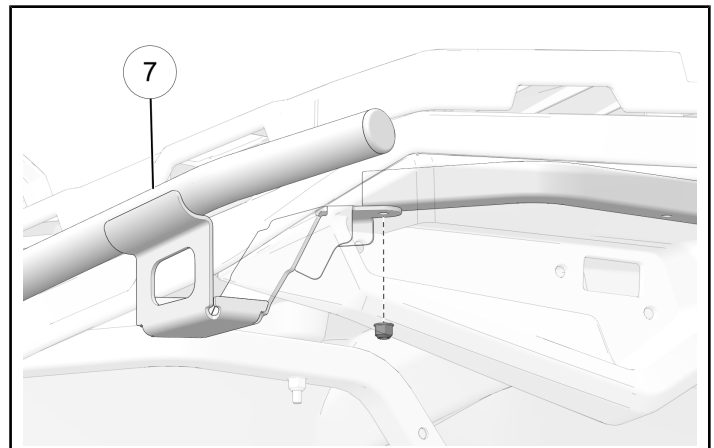

6. Loosely install the two rear footwell tube screws ④ and nuts ⑫ to hold the assembly into place.

IMPORTANT

Do not tighten the fasteners at this time.

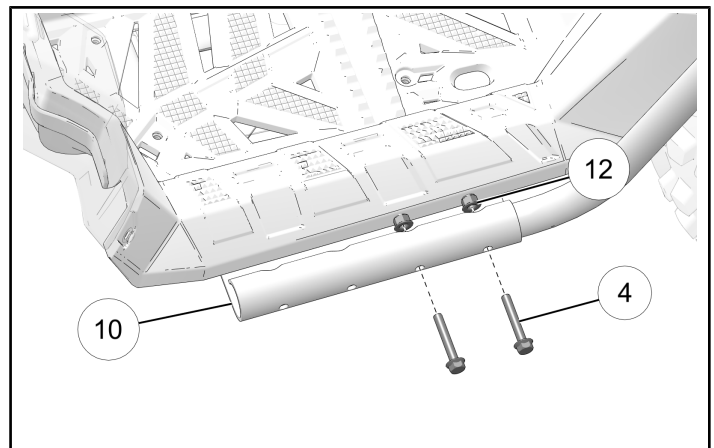

- Loosely install the two rear footwell screws ⑧ and nuts ⑨ to hold the assembly into place.

IMPORTANT

Do not tighten the fasteners at this time.

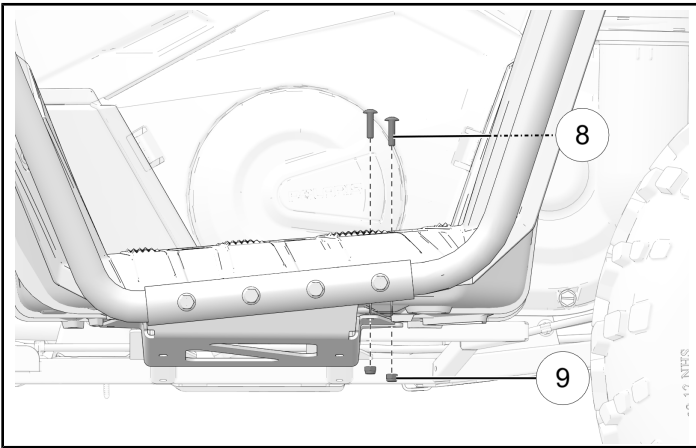

- Slide the front left-hand side guard weld ① into the left-hand bracket mount ⑩ and lift the assembly into place.

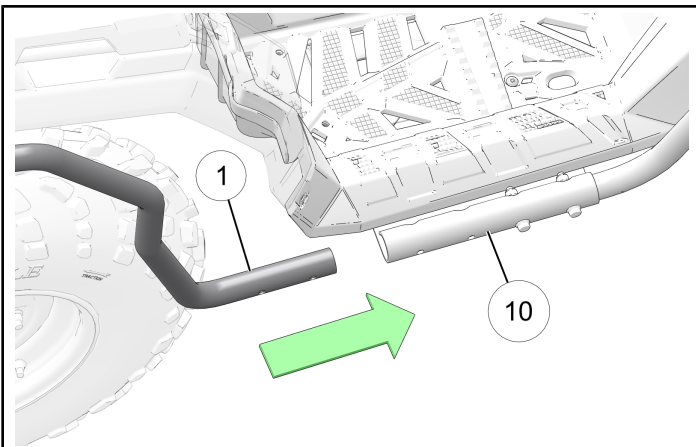

- Loosely install the front footwell tube screws ④ and nuts ⑫.

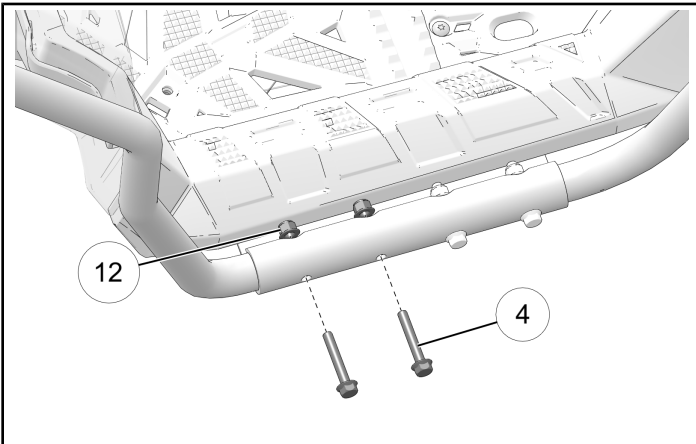

- Align the front left-hand side guard weld ① with the front left side of the applicable front bumper kit. Install the bumper screw ② through the front bumper and into the front left-hand side guard weld ①.

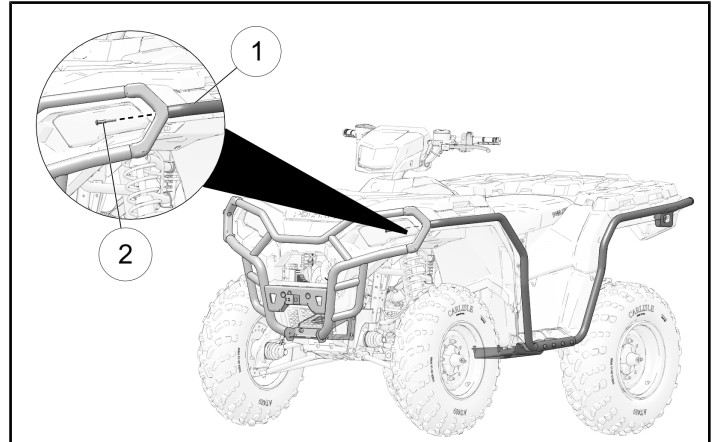

- Torque all fasteners in the following order to specification.

TORQUE

Footwell Mounting Bracket Fasteners ⑧ and ⑨:
3 ft-lbs (4 N·m)

Front Bumper Socket Head Screw ②:
7 ft-lbs (10 N·m)

Rear Rack Tube Support Nuts:
35 in-lbs (4 N·m)

Footwell Tube Fasteners ④ and ⑫:
17 ft-lbs (23 N·m)

- Repeat the above steps on the other side of the vehicle.

INSTRUCTION FEEDBACK FORM

A feedback form has been created for the installer to provide any comments, questions or concerns about the installation instructions. The form is viewable on mobile devices by scanning the QR code or by clicking [HERE](#) if viewing on a PC.

