

# FRONT BUMPER KIT



P/N 2884577

## BEFORE YOU BEGIN

Read these instructions and check to be sure all parts and tools are accounted for. Please retain these installation instructions for future reference and parts ordering information.

## APPLICATION

Verify accessory fitment at [www.polaris.com](http://www.polaris.com).

## KIT CONTENTS

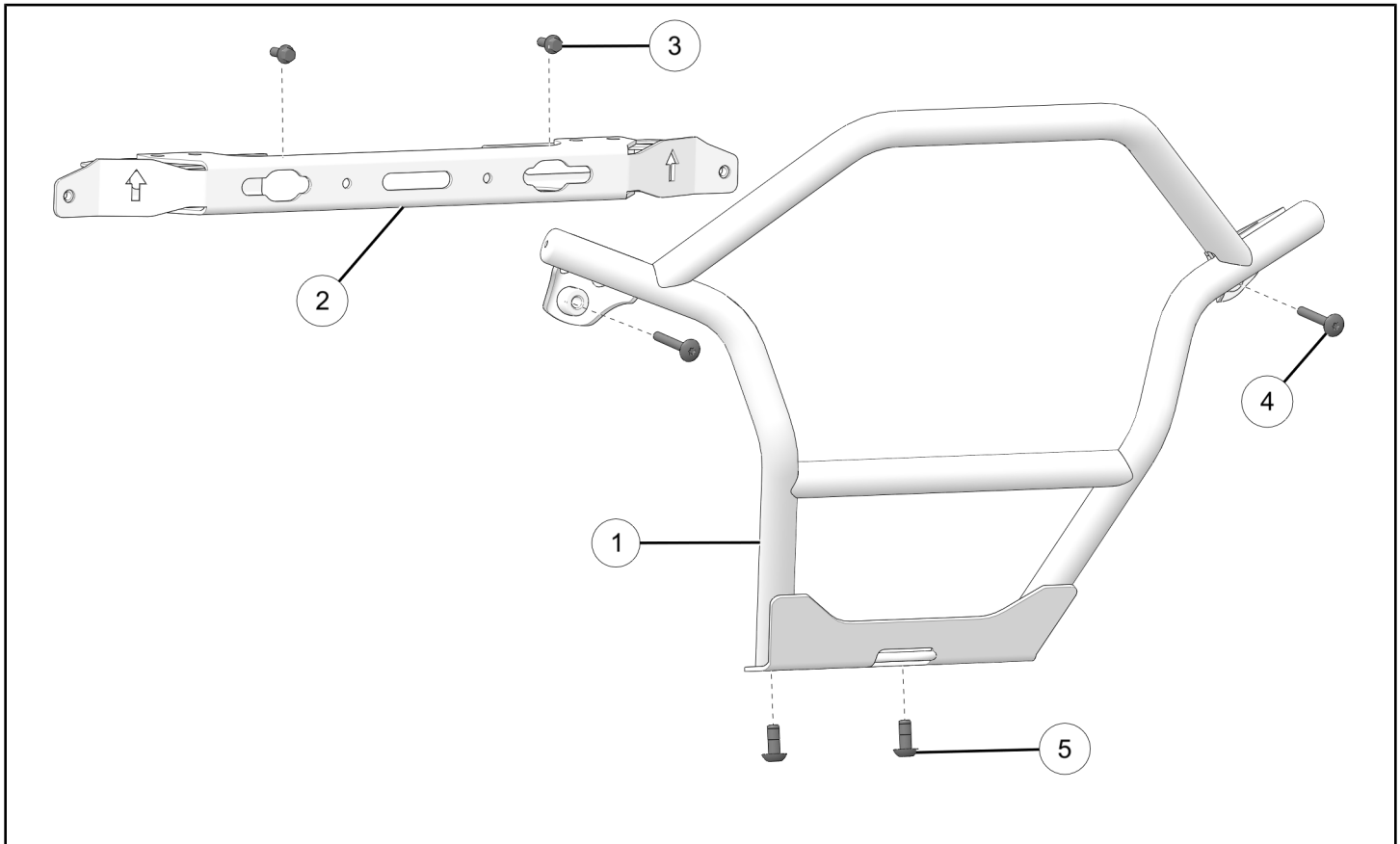

REF	QTY	PART DESCRIPTION	P/N AVAILABLE SEPARATELY	AVAILABLE SERVICE KIT
1	1	Bumper, Front	n/a	n/a
2	1	Front Plastic Mount, Black	1025697-458	n/a
3	2	Screw – Hex Flange, M6 x 1.0 x 16.0 mm	7518637	2208952
4	2	Screw – Torx® Truss Head, M6 x 1.0 x 45 mm	7519281	2208952
5	2	Screw – Torx® Truss Head, M8 x 1.25 x 20 mm	7519997	2208952

## TOOLS REQUIRED

- Safety Glasses
- Pliers, Push Pin Rivet
- Socket Set, Metric
- Socket Set, Torx® Bit
- Torque Wrench

## IMPORTANT

Your Front Bumper Kit is exclusively designed for your vehicle. Please read the installation instructions thoroughly before beginning. Installation is easier if the vehicle is clean and free of debris. For your safety, and to ensure a satisfactory installation, perform all installation steps correctly in the sequence shown.

## INSTALLATION INSTRUCTIONS

### VEHICLE PREPARATION

#### GENERAL

1. Park vehicle on a flat surface.
2. Push engine stop switch to OFF position.
3. Turn key to OFF position and remove key.
4. Disconnect both right and left headlights.

#### NOTICE

Right side shown, left side similar.

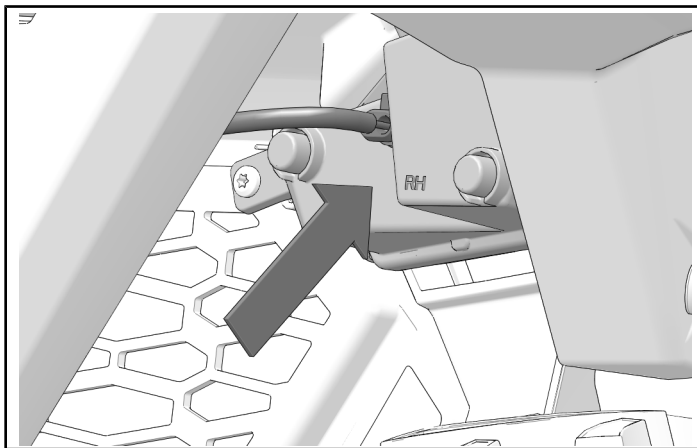

5. Remove and keep four push pin rivets.

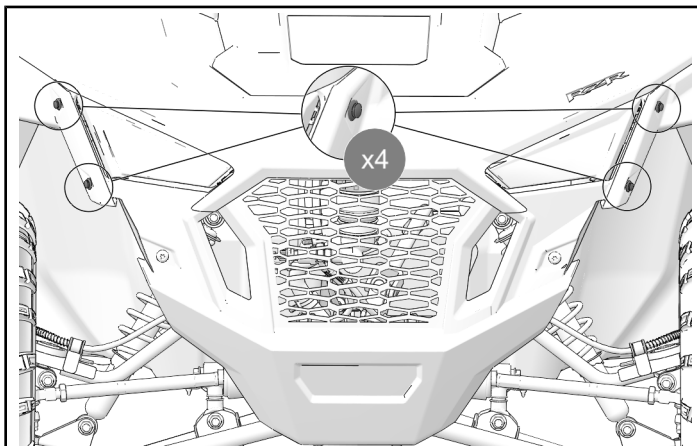

6. Remove and discard four screws from the front fascia. Set aside front fascia.

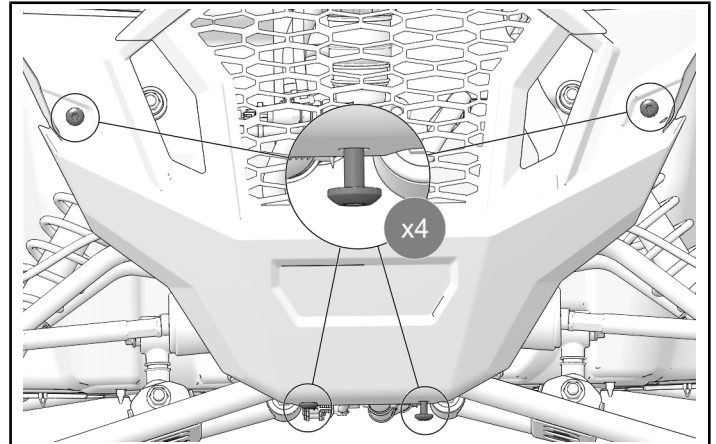

7. Disconnect the brake switch.

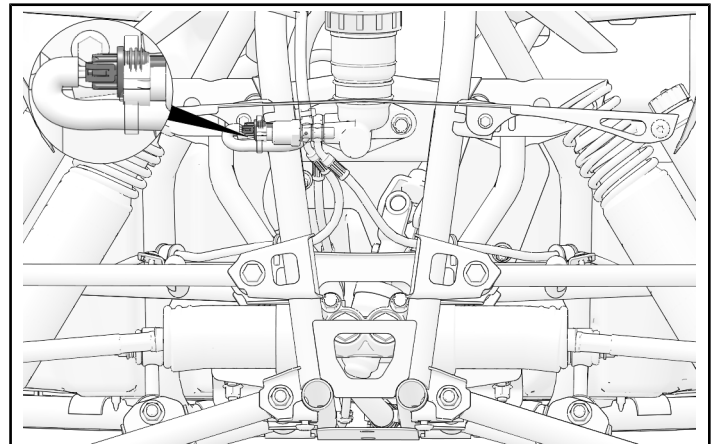

- Remove and discard two screws from front fascia bracket. Remove and discard front fascia bracket.

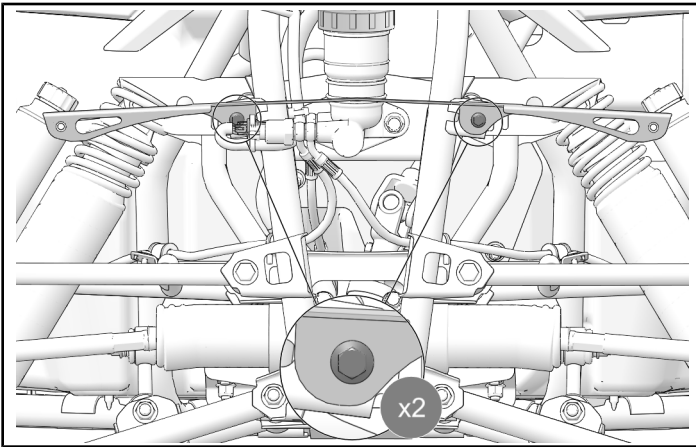

## ACCESSORY INSTALLATION

- Install front mount ② with two screws ③. Torque screws to specification.

### IMPORTANT

Make sure arrows on mount are pointing up.

### TORQUE

Front Mount Screws ③:  
84 in-lbs (9.5 N·m)

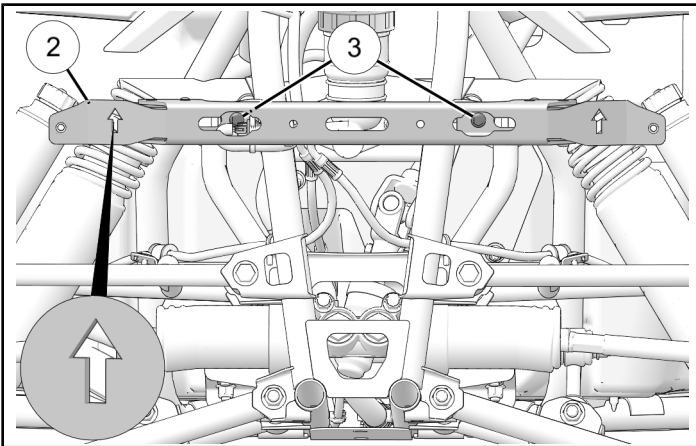

- Reconnect the brake switch.

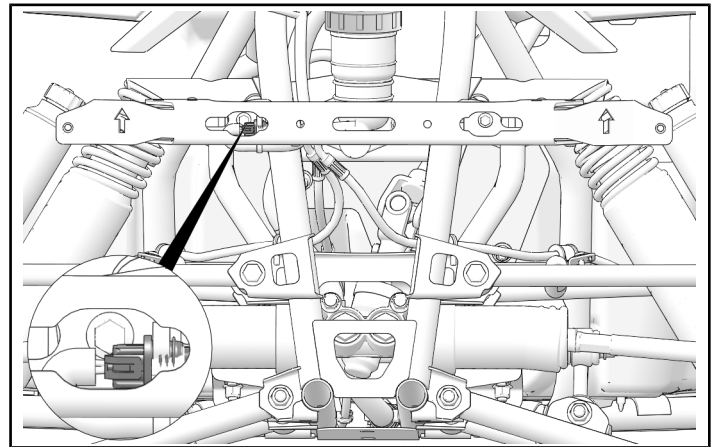

- Install front fascia using four retained push pin rivets.

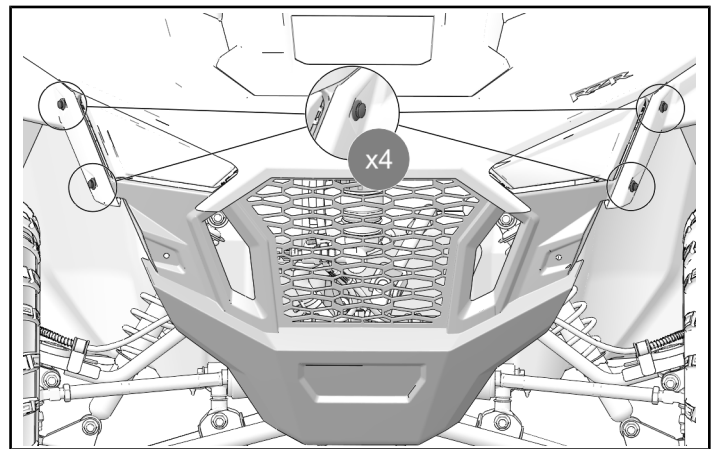

- Reconnect both right and left headlights.

### NOTICE

Right side shown, left side similar.

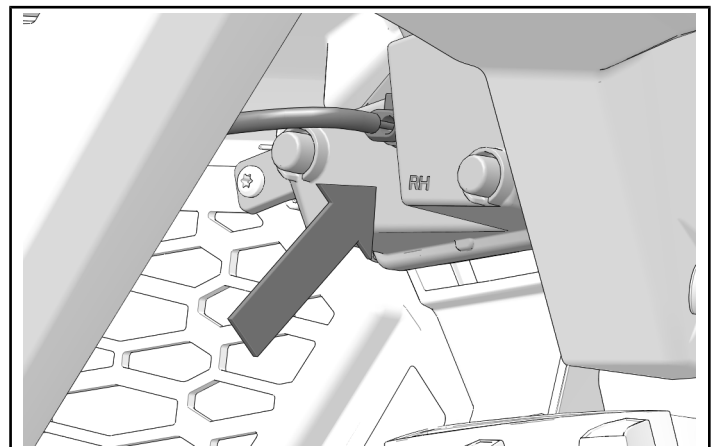

5. Position front bumper ① and loosely install two upper screws ④.

**DO NOT torque fasteners at this time.**

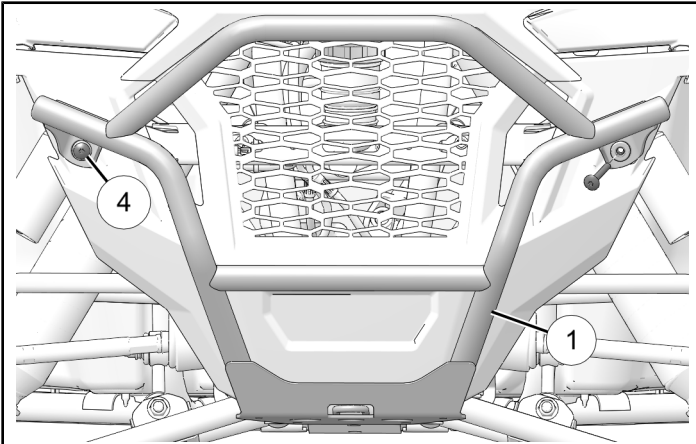

7. Torque upper screws ④ to specification.

**TORQUE**

Upper Screws ④:  
**84 in-lbs (9.5 N·m)**

6. Install two lower screws ⑤. Torque to specification.

**TORQUE**

Lower Screws ⑤:  
**17 ft-lbs (23 N·m)**

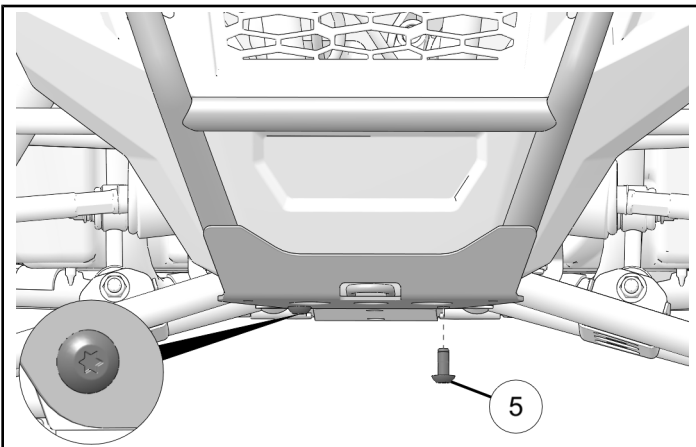

**INSTRUCTION FEEDBACK FORM**

A feedback form has been created for the installer to provide any comments, questions or concerns about the installation instructions. The form is viewable on mobile devices by scanning the QR code or by clicking [HERE](#) if viewing on a PC.

