

# ZIP WINDOW FRONT CANVAS DOOR KIT



P/N 2885075

## MISSING OR DAMAGED PARTS

Before beginning assembly, inspect the kit and its component(s) to be sure all parts and tools are accounted for and not damaged. If missing parts or parts are damaged, please contact your Selling Dealer for assistance.

If your accessory was purchased online, please contact POLARIS® customer service at **1-800-POLARIS** (US & Canada only).

## APPLICATION

Verify accessory fitment at [www.polaris.com](http://www.polaris.com).

## KIT CONTENTS

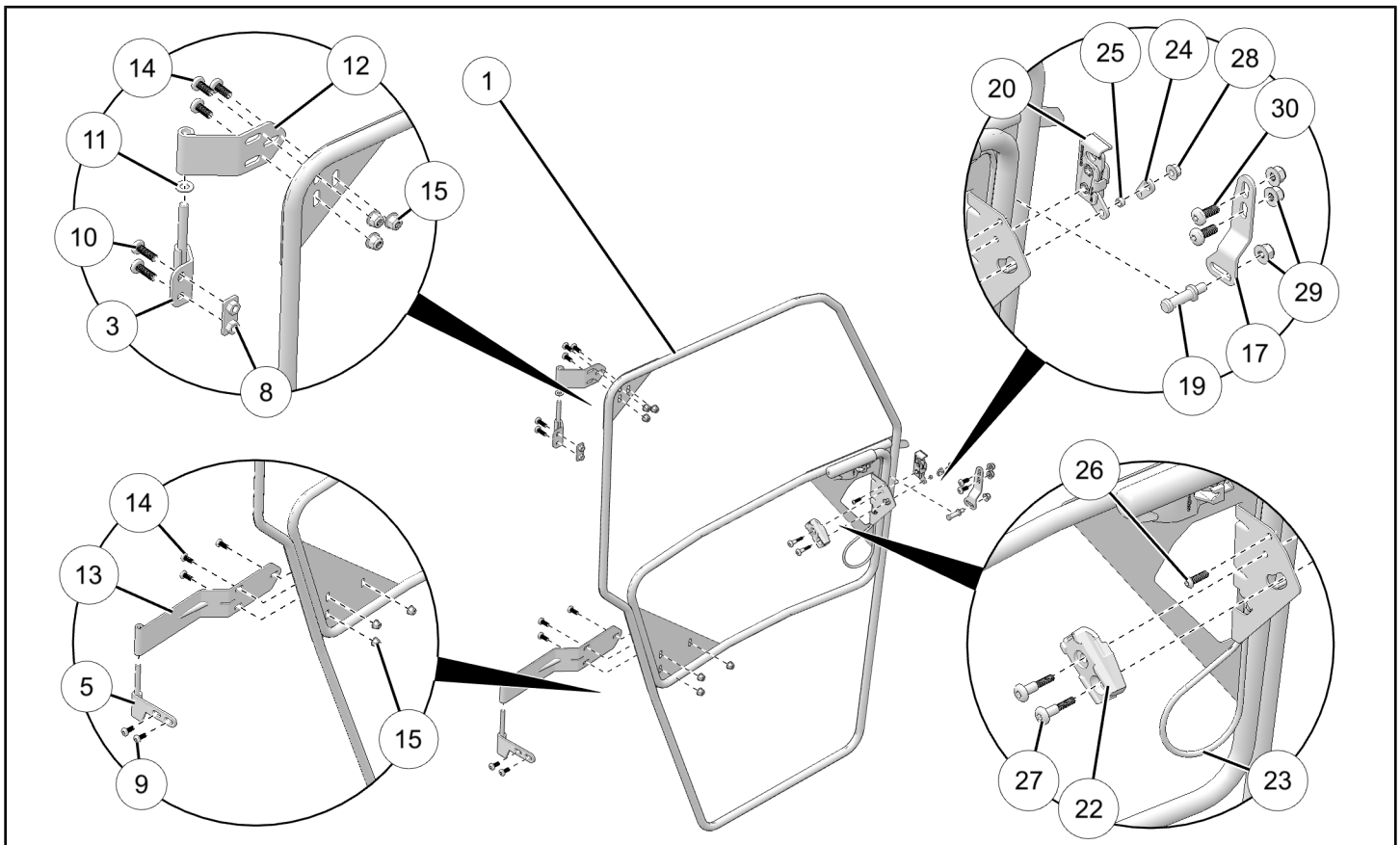

REF	QTY	PART DESCRIPTION	P/N AVAILABLE SEPARATELY	AVAILABLE SERVICE KIT
1	1	Front Door Assembly, Left	2638157	n/a
2	1	Front Door Assembly, Right (not shown)	2638158	n/a
3	1	Upper Left Vehicle Hinge	n/a	2209557
4	1	Upper Right Vehicle Hinge (not shown)	n/a	2209557
5	1	Lower Left Vehicle Hinge	n/a	2209557
6	1	Lower Right Vehicle Hinge (not shown)	n/a	2209557

REF	QTY	PART DESCRIPTION	P/N AVAILABLE SEPARATELY	AVAILABLE SERVICE KIT
7	-	(unused)	-	-
8	2	Nut Plate	n/a	2209557
9	4	Screw, Screw, Torx® Drive Button Head, M8 x 1.25 x 20 mm	n/a	2209557
10	4	Screw, Screw, Torx® Drive Button Head, M8 x 1.25 x 25 mm	n/a	2209557
11	4	Washer, Nylon, 0.39 x .062	n/a	2209557
12	2	Upper Door Hinge	n/a	2209558
13	2	Lower Door Hinge	n/a	2209558
14	12	Screw, Screw, Torx® Drive Button Head, M8 x 1.25 x 20 mm	n/a	2209558
15	12	Nut, M8 x 1.25 mm	n/a	2209558
16	4	Washer, Nylon, 0.39 x .062 (not shown)	n/a	2209558
17	1	Striker Mounting Plate, Left	n/a	2209559
18	1	Striker Mounting Plate, Right (not shown)	n/a	2209559
19	2	Striker Pin	n/a	2209559
20	1	Latch, Left	n/a	2209559
21	1	Latch, Right (not shown)	n/a	2209559
22	2	Latch Release Knob	n/a	2209559
23	2	Latch Cable	n/a	2209559
24	2	Latch Pull Tab	n/a	2209559
25	2	Spacer	n/a	2209559
26	2	Screw, Screw, Torx® Drive Button Head, M6 x 1.0 x 20 mm	n/a	2209559
27	4	Screw, Screw, Torx® Drive Button Head, M6 x 1.0 x 35 mm	n/a	2209559
28	2	Nut, Hex Flange, M6 x 1.0 mm	n/a	2209559
29	6	Nut, Hex Flange, M8 x 1.25 mm	n/a	2209559
30	4	Screw, Screw, Torx® Drive Button Head, M8 x 1.25 x 20 mm	n/a	2209559
31	1	Rear Door Striker Mounting Plate, Left (not shown) - Not used for Kit 2885075	n/a	2209559
32	1	Rear Door Striker Mounting Plate, Right (not shown) - Not used for Kit 2885075	n/a	2209559
33	4	Screw, Screw, Torx® Drive Button Head, M8 x 1.25 x 25 mm - Not used for Kit 2885075	n/a	2209559

## TOOLS REQUIRED

- Safety Glasses
- Cutting Tool
- Deburring Tool
- Screwdriver Set, Torx®
- Socket Set, Metric
- Torque Wrench
- Wrench Set, Metric

## CONSUMABLES REQUIRED

- Gloves, Chemical Resistant
- Grease, Polaris® All Season (or equivalent)

## IMPORTANT

Your Zip Window Front Canvas Door Kit is exclusively designed for your vehicle. Please read the installation instructions thoroughly before beginning. Installation is easier if the vehicle is clean and free of debris. For your safety, and to ensure a satisfactory installation, perform all installation steps correctly in the sequence shown.

## INSTALLATION INSTRUCTIONS

### VEHICLE PREPARATION

#### GENERAL

1. Park vehicle on a flat surface.
2. Shift vehicle into PARK.
3. Turn key to OFF position and remove key.

#### TILTING CARGO BOX

1. Pull upwards on cargo box lever to rotate cargo box upwards.

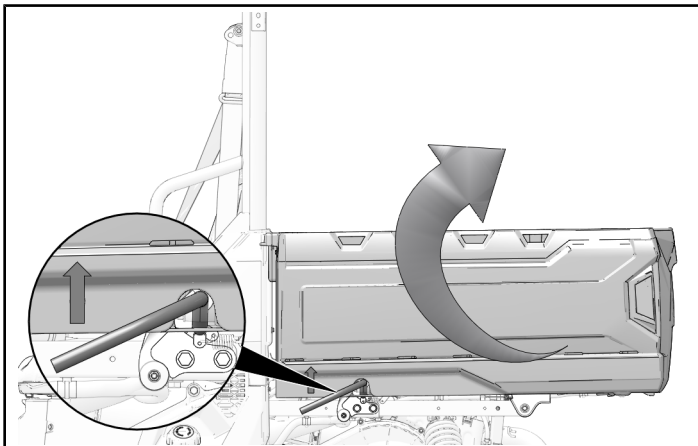

### UPPER ROCKER PANEL REMOVAL

#### NOTICE

Left side shown; right side similar.

1. Remove and keep four push-pin rivets from upper rocker panel.

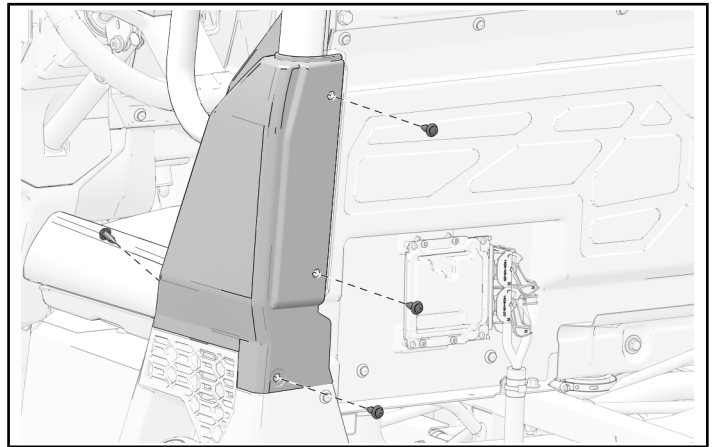

2. Loosen, but do not remove, screw on retaining hook. Rotate hook until it is free of bolster tube.

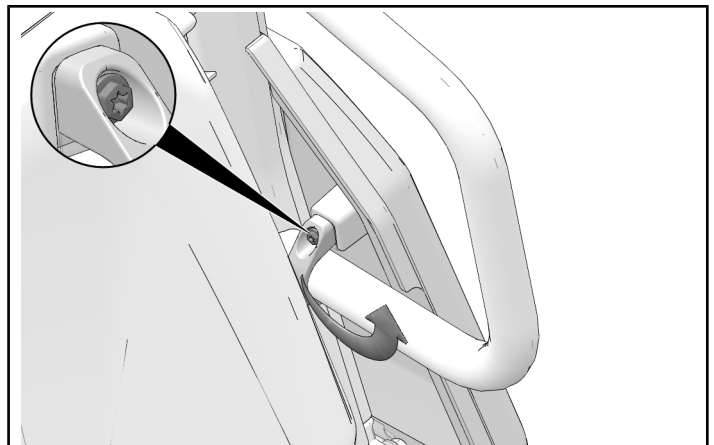

3. Remove upper rocker panel from vehicle.

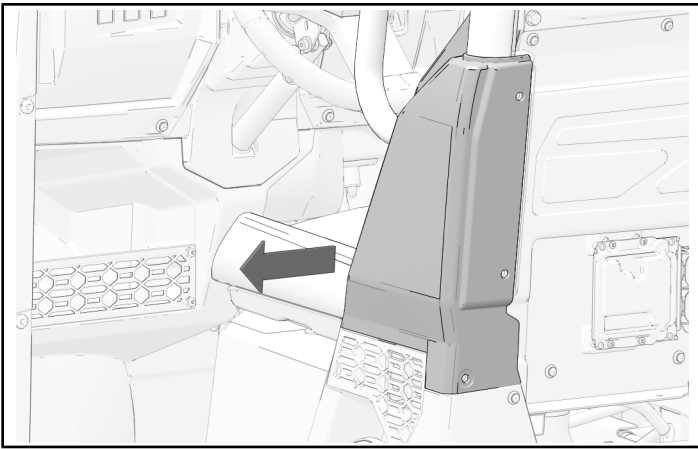

## ACCESSORY INSTALLATION

### NOTICE

Polaris recommends two people assemble and install this kit.

1. To access the inside of the canvas skin, unzip the window and inside of the canvas skin to expose the door frame.
2. Loosely install upper left door side hinge ⑫ to left door frame ① using three screws ⑭ and nuts ⑮.

### NOTICE

Canvas skin not shown for clarity.

Do not torque screws at this time.

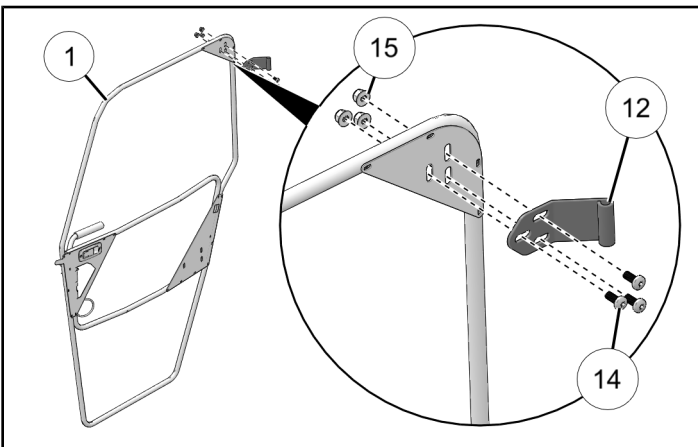

3. Loosely install lower left door side hinge ⑬ to left door frame ① using three screws ⑭ and nuts ⑮.

Do not torque screws at this time.

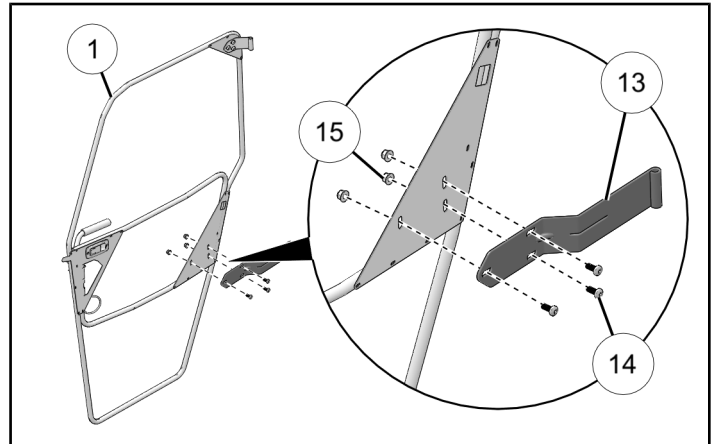

4. Loosely install upper left hinge ③ to ROPS bracket using two screws ⑩ and nut plate ⑧. Center hinge over screw holes in vehicle, then partially tighten screws.

Do not torque screws at this time.

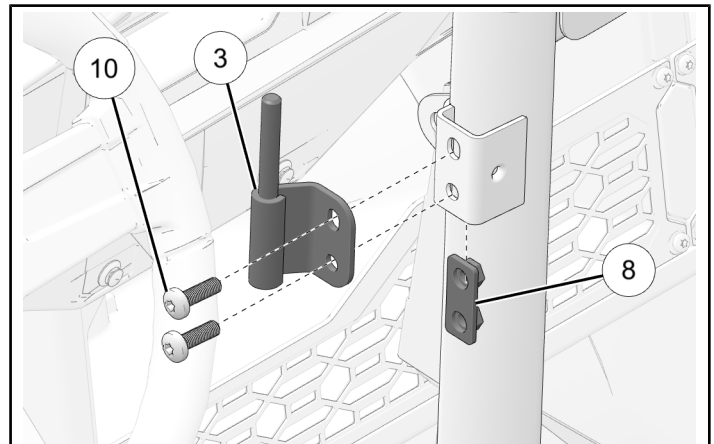

- Loosely install lower left hinge ⑤ to chassis using two screws ⑨. Center hinge over screw holes in vehicle, then partially tighten screws.

Do not torque screws at this time.

#### NOTICE

Lower hinge pin is longer than upper hinge pin to assist in door installation.

The hinge pin should be on the front side of the hinge bracket when installed on the vehicle. This will help differentiate left and right hinges.

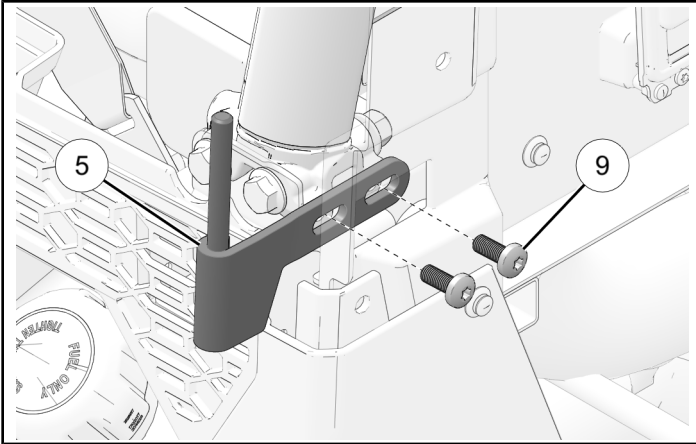

- Install nylon washers ⑪ to pins on upper hinge ③ and lower hinge ⑤.

#### NOTICE

Washer acts as bearing surface to assist in smooth door operation.

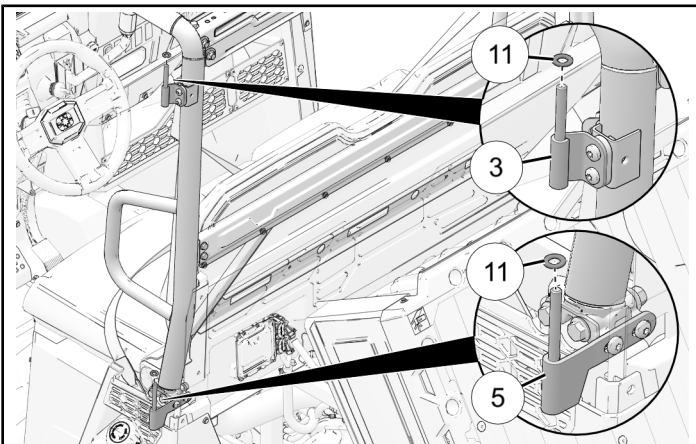

#### WARNING

Follow all chemical manufacturer instructions and safety precautions. Failure to follow all manufacturer instructions and precautions may result in severe injury or death.

- Grease pins on upper and lower hinges ③ and ⑤ using Polaris® All Season Grease (or equivalent).
- Install door assembly ① on lower hinge ⑤ first, then upper hinge ③.

#### NOTICE

Lower hinge pin is longer than upper hinge pin to assist in door installation.

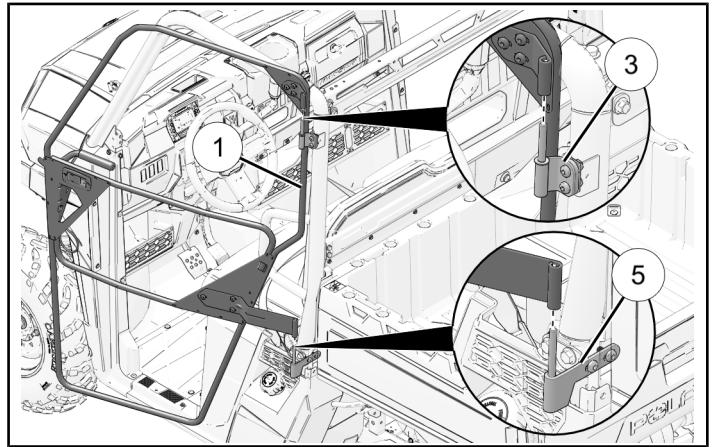

- Close door, pushing into ROPS, and observe gap between door frame ① and ROPS/chassis structure (around entire perimeter of door):
  - IF PERIMETER GAP IS EVEN:** Make sure no hinge gap exists between bottom of DOOR side hinges ⑫ and ⑬, and nylon washer ⑪ on corresponding CHASSIS side hinges ③ and ⑤ (to equalize door loading on hinges). If necessary, adjust height of upper chassis side hinge ③ to eliminate hinge gap. When complete, tighten all six door side hinge nuts ⑭.

#### TIP

Have one person hold and center the door, and a second person tighten the fasteners.

- IF PERIMETER GAP IS UNEVEN:** Loosen two upper and two lower CHASSIS side hinge screws ⑩ and ⑨, center door in ROPS, then re-tighten chassis side hinge screws. When complete, go to previous section, **IF PERIMETER GAP IS EVEN**.

10. Torque all hinge fasteners to specification.

**TORQUE**

M8 Screws ⑨ & ⑩:  
17 ft-lbs (23 N·m)

**TORQUE**

Nuts ⑮:  
5 ft-lbs (7 N·m)

11. Check latch operation and adjust cable as needed by moving the cable adjustment notch to a different position.

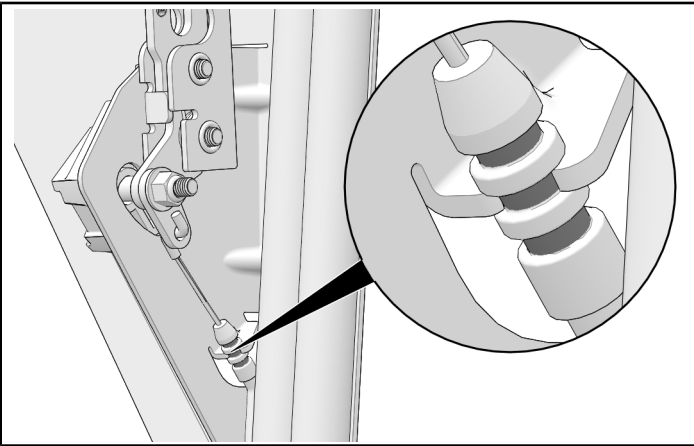

12. Zip up the canvas skin.

13. Assemble striker pin ⑲ to striker bracket ⑰ using nut ⑳. Tighten nut.

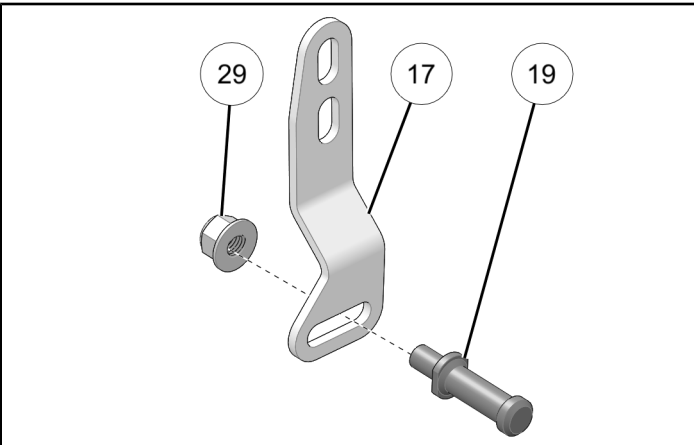

14. Loosely install striker bracket ⑰ to chassis structure using two screws ⑳ and nuts ㉑. Center striker over screw holes in chassis, then partially tighten screws.

Do not torque screws at this time.

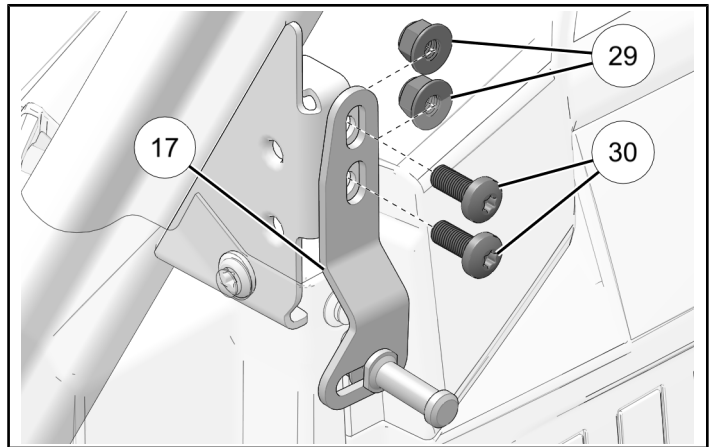

15. Open interior door latch ㉒ (to ensure proper position of pawl), then slowly close door and observe engagement of striker pin ⑲ into door latch.

Adjust location of striker pin bracket to achieve the following:

**NOTICE**

Striker shown detached from chassis structure for clarity.

- a. **EXTENSION:** Head of pin ⑲ should fully clear latch pawls ㉓ as shown. To extend pin rearward, remove the striker ⑲ and nut ㉑, place shim between striker bracket ⑰ and striker ⑲, then reinstall nut.

**NOTICE**

If head of pin extends **too far rearward**, even without shim, then entire door must be moved rearward by adjusting door side hinges. See Steps 1–2.

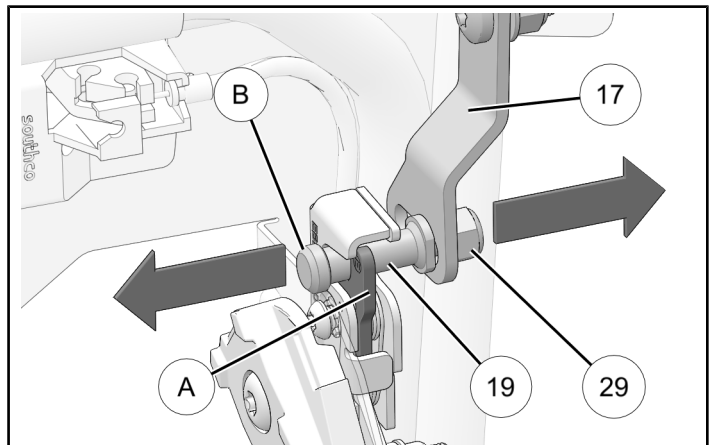

- b. **HEIGHT:** Pin 19 should be centered vertically in opening of latch pawls A. To adjust, loosen two screws 30, slide striker bracket 17 up or down as required, then retighten screws.

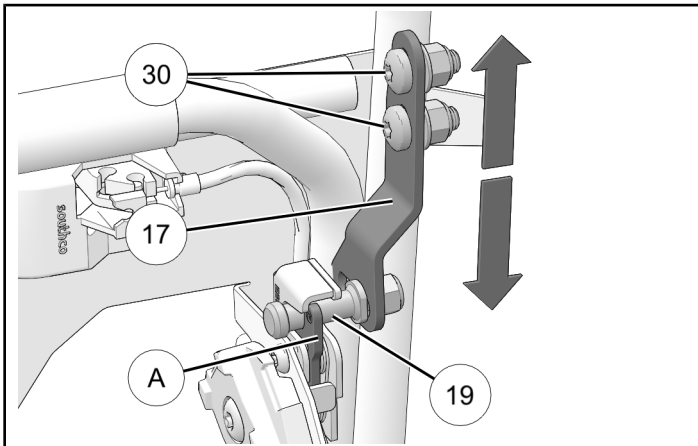

- c. **DEPTH:** As required to achieve desired fairing between door frame 1 and ROPS/chassis door structure. To adjust, loosen the striker 19 and nut 29. Slide striker 19 inboard or outboard on the striker bracket as required, then reinstall striker and nut.

Make sure depth adjustment is made with latch pawls A at FULL closure as shown below (second “click”), not at partial closure (first “click”).

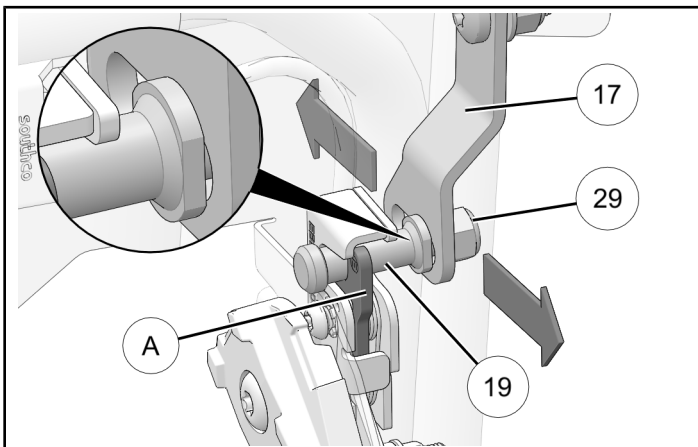

16. Make sure proper operation of interior latch and exterior latch. Adjust as required, then tighten all latch screws. See step 15.

17. Torque the following fasteners to specification:

#### TORQUE

M8 Screws 30:  
17 ft-lbs (23 N·m)

#### TORQUE

Striker Nut 29:  
17 ft-lbs (23 N·m)

18. Next, flip the upper rocker panel over and draw a vertical line where the plastic starts to angle, then a horizontal line across the radius, and then a vertical line that connects to the witness mark. This outline shows where the panel material must be removed to allow clearance for the hinge. Cut on the inside of the line to remove the panel material.

#### TIP

Use the measurements provided below when drawing lines on the panel to make sure the correct panel material is removed.

#### IMPORTANT

Control tool depth. Make sure tool is clear of all other parts and components to prevent damage to vehicle.

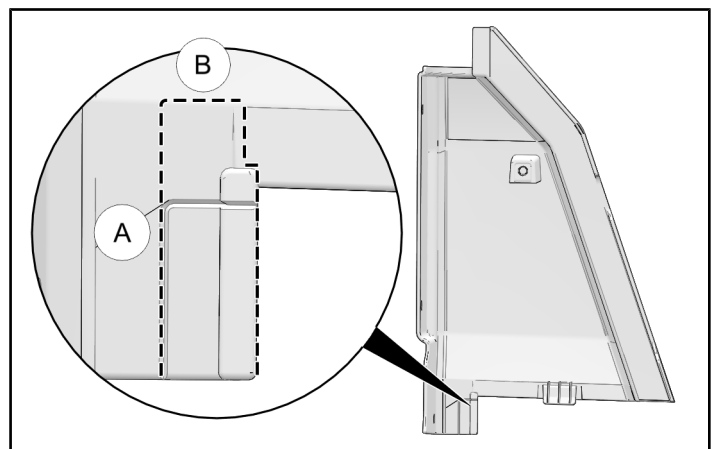

A = 2 1/4 in (5.715 cm)

B = 1/2 in (1.270 cm)

19. Remove remaining plastic with a suitable tool.  
20. Use a deburring tool to clean up the edges of the upper rocker panel.

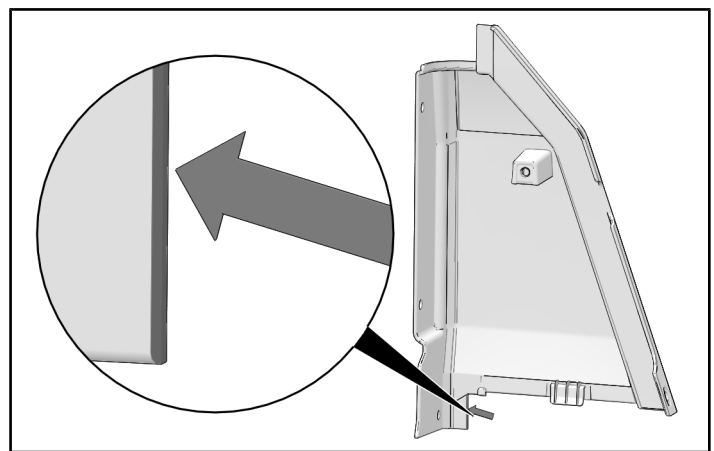

21. Repeat Steps 1–20 for right door frame 2 using right hinges 4, 6, 12, 13.

## VEHICLE REASSEMBLY

### UPPER ROCKER PANEL INSTALLATION

#### NOTICE

Left side shown; right side similar.

1. Put upper rocker panel in installed position.

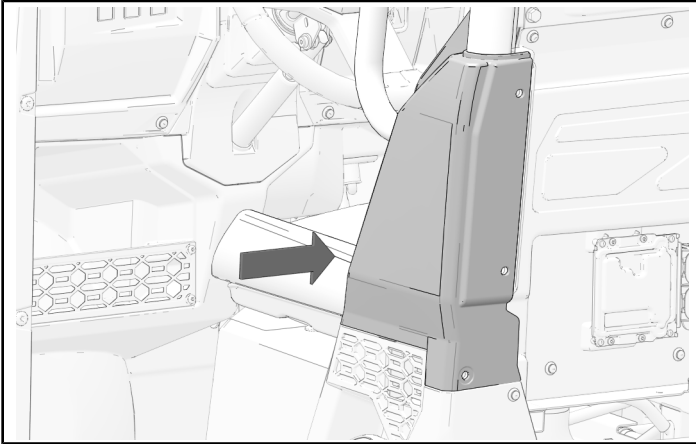

2. Rotate hook over bolster tube.

Do not torque screw at this time.

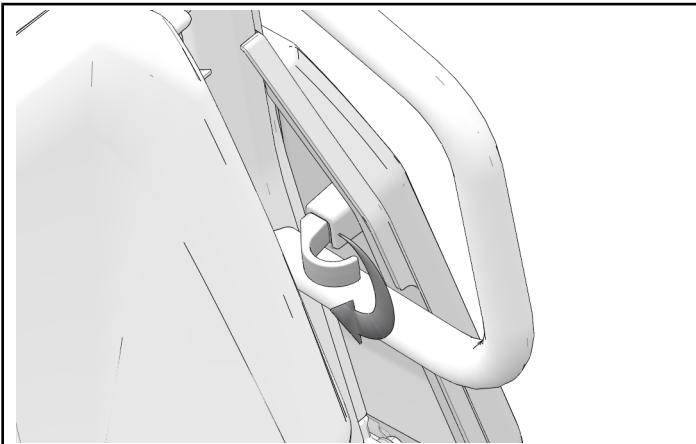

3. Install upper rocker panel with four retained push-pin rivets.

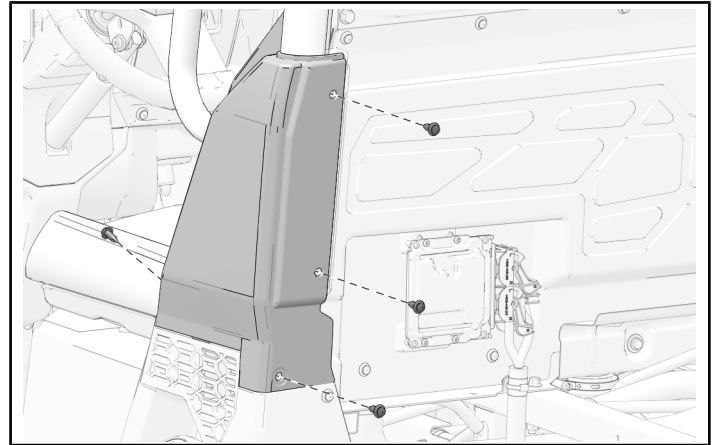

4. Tighten screw in retaining hook until it is fully seated.

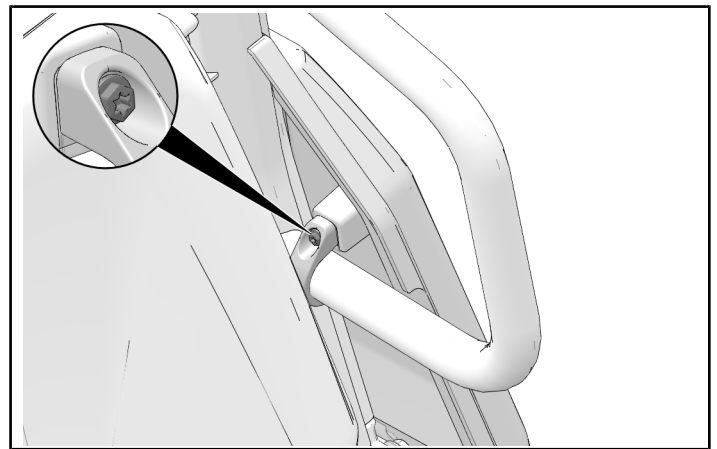

#### GENERAL

1. Lower the cargo box.