

HORN KIT



P/N 2884488

MISSING OR DAMAGED PARTS

Before beginning assembly, inspect the kit and its component(s) to be sure all parts and tools are accounted for and not damaged. If missing parts or parts are damaged, please contact your Selling Dealer for assistance.

If your accessory was purchased online, please contact POLARIS® customer service at **1-800-POLARIS** (US & Canada only).

APPLICATION

Verify accessory fitment at www.polaris.com.

KIT CONTENTS

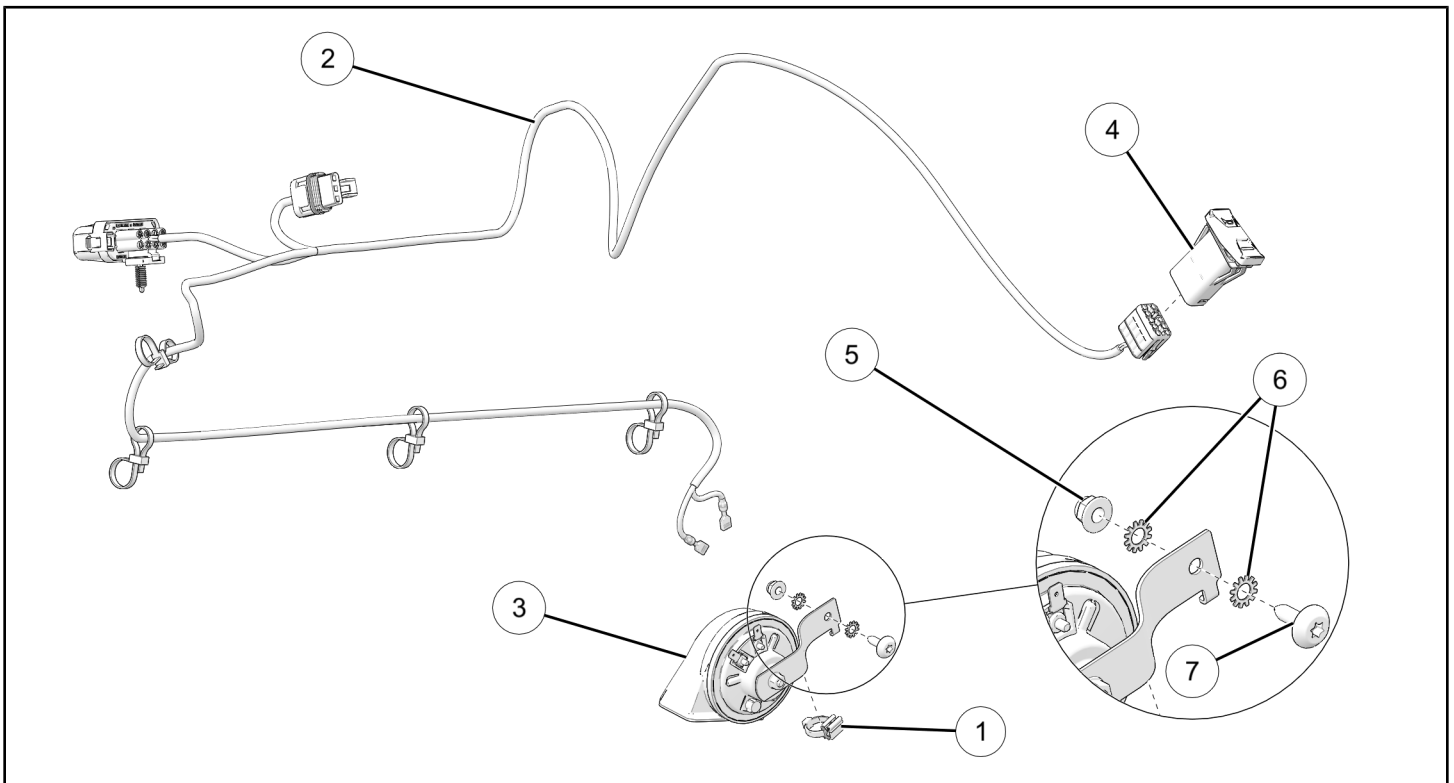

REF	QTY	PART DESCRIPTION	P/N AVAILABLE SEPARATELY	AVAILABLE SERVICE KIT
1	1	Edge Clip	7082402	2211892
2	1	Harness – Accessory, Horn	n/a	n/a
3	1	Horn	n/a	n/a
4	1	Horn Switch	4080801-09	n/a
5	1	Nut, Hex Flange M6 x 1.0 mm	7547453	2211892
6	2	Toothed Washer	7552604	2211892
7	1	Screw, Torx® Truss Head M6 x 1.0 x 20 mm	7519112	2211892

HARNES DETAIL

HORN HARNES ②



REF	PART DESCRIPTION	CONNECTS TO
1F	Terminal – Horn Ground (Brown)	Horn Negative (-) ③
1F	Terminal – Horn + (Dark Blue/Black)	Horn Positive (+) ③
3F	Connector – Pulse Bar	Pulse bar
8F	Connector – Fuse Block	Fuse Block
10F	Connector – Horn Switch	Horn Switch ④

Example: 16F = 16 pin, Female / 16M = 16 pin, Male (Male terminal fits inside female terminal)

TOOLS REQUIRED

- Safety Glasses
- Drill
- Drill Bit:
 - 1/4 in (7 mm)
- Push Dart (Panel Clip) Tool
- Socket Set, Metric
- Wrench Set, Metric
- **Special Service Tool:**
 - Non-marring Pry Tool, P/N 5456907 (or equivalent)

IMPORTANT

Your Horn Kit is exclusively designed for your vehicle. Please read the installation instructions thoroughly before beginning. Installation is easier if the vehicle is clean and free of debris. For your safety, and to ensure a satisfactory installation, perform all installation steps correctly in the sequence shown.

INSTALLATION INSTRUCTIONS

VEHICLE PREPARATION

GENERAL

1. Park vehicle on a flat surface.
2. Shift vehicle into PARK.
3. Turn key to OFF position and remove key.

HOOD AND GRILL REMOVAL

1. Turn each stud one-quarter turn to release grill.

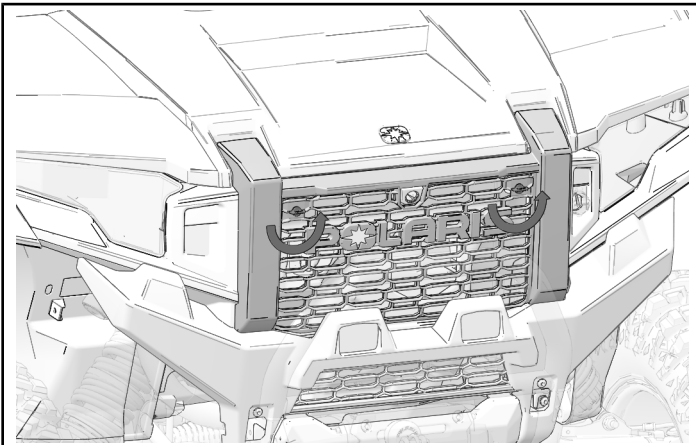

2. Pull top of grill forward and then lift up to remove grill.

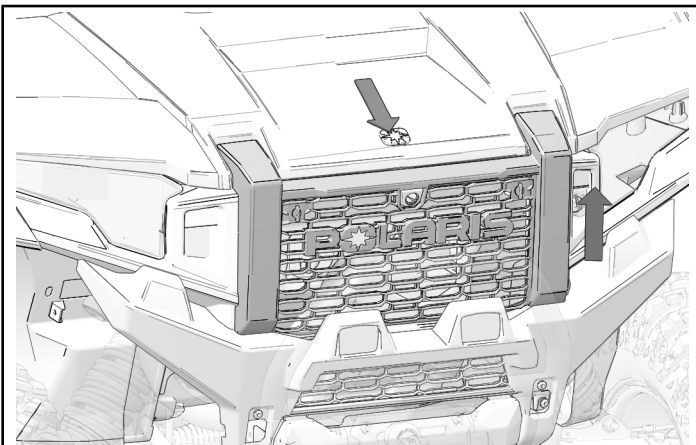

3. Pull rubber straps off hooks to release hood. Lift hood to remove.

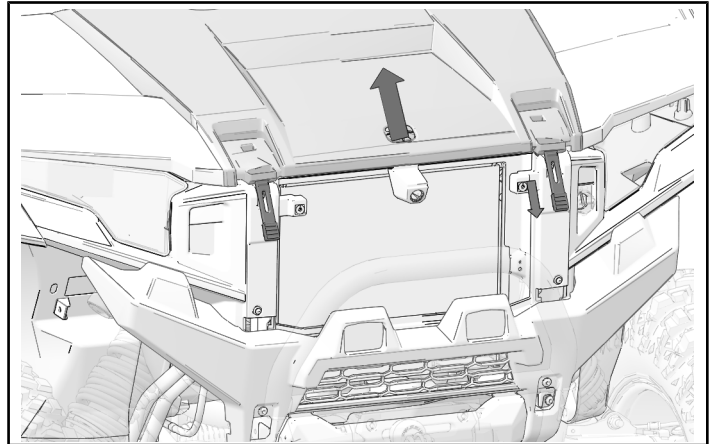

CENTER DASH PANEL REMOVAL

VEHICLES WITH TIP-OUT WINDSHIELD

NOTICE

For vehicles without tip-out windshield, proceed to Panel Removal.

1. Open tip-out windshield.

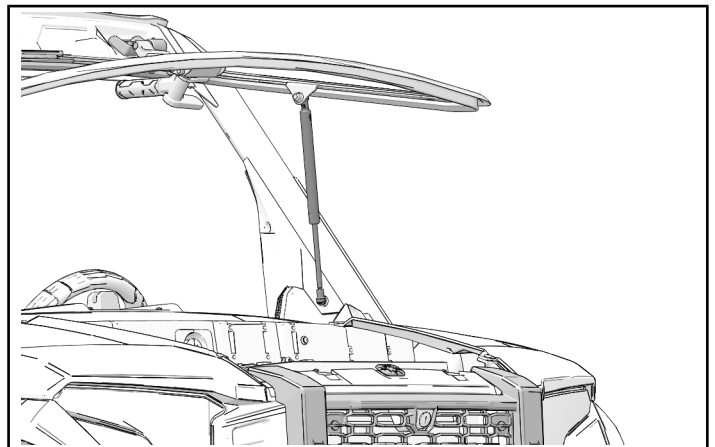

2. Remove and keep three screws and washers. Remove and keep windshield base.

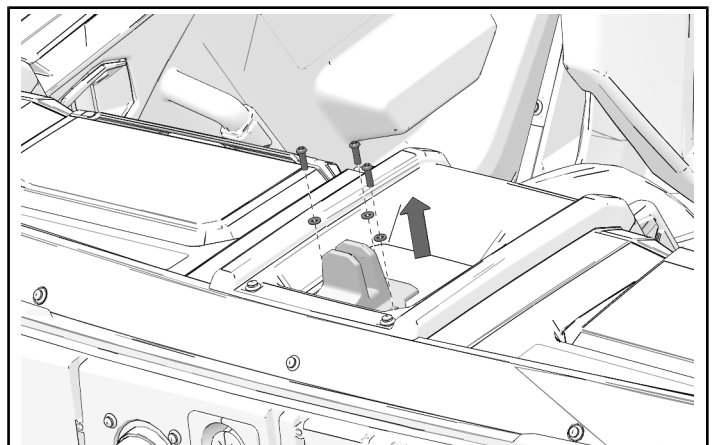

PANEL REMOVAL

1. Remove and keep two push-pin rivets from center dash panel.

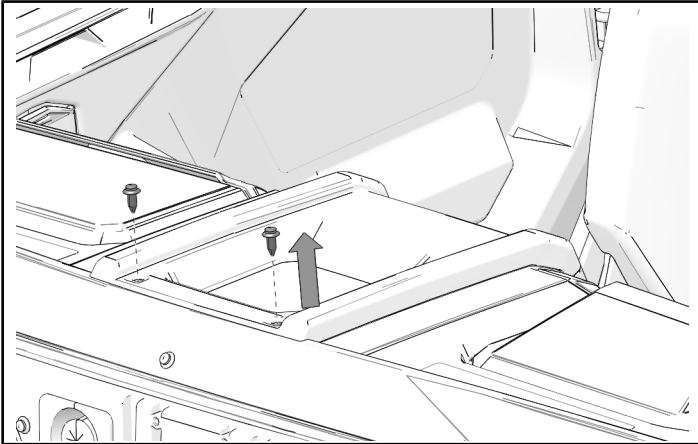

2. Remove and keep panel by lifting front edge and moving backward.

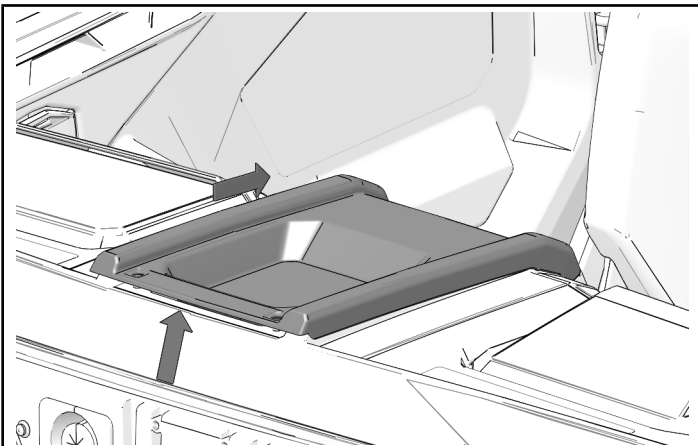

HEAD UNIT REMOVAL

NOTICE

Vehicles without audio system will have a storage bin in place of head unit. Storage bin is removed in a similar manner to head unit.

NOTICE

Base audio head unit removal shown. Ride Command® display removal similar.

1. Remove and keep two push-pin rivets from top of the head unit.

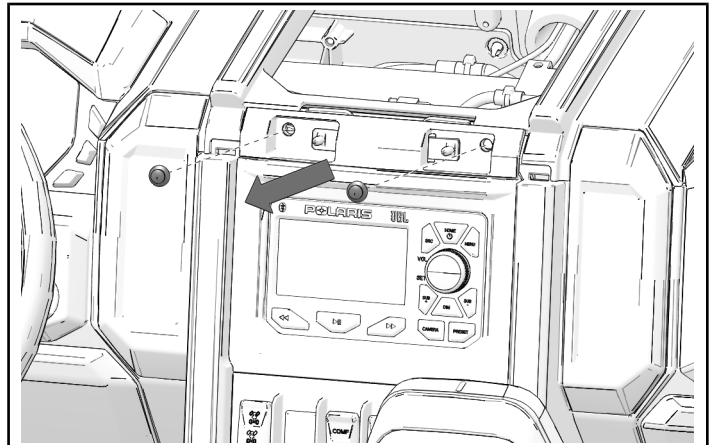

2. Pull top of head unit away from dash and lift head unit up to remove from dash.

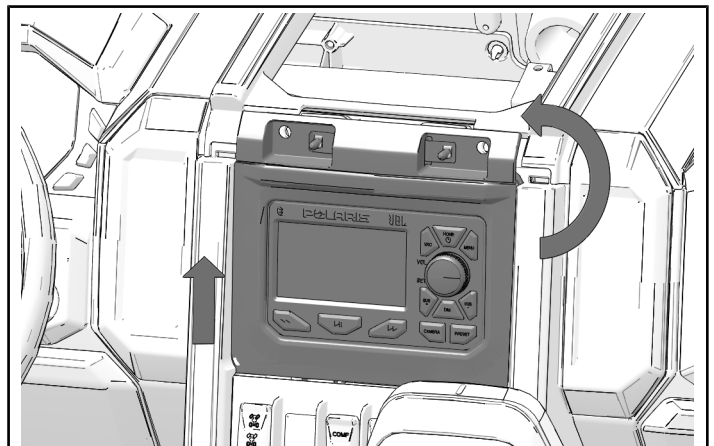

3. Disconnect wiring harness and antenna from head unit. Remove and keep head unit.

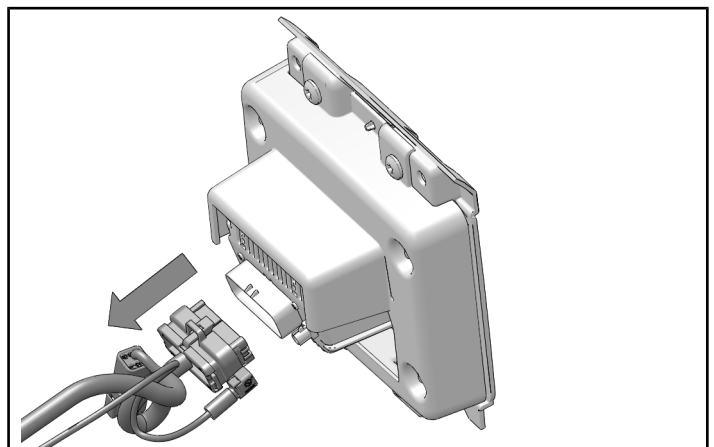

ACCESSORY INSTALLATION

1. If vehicle is equipped with front camera, disconnect front camera harness.

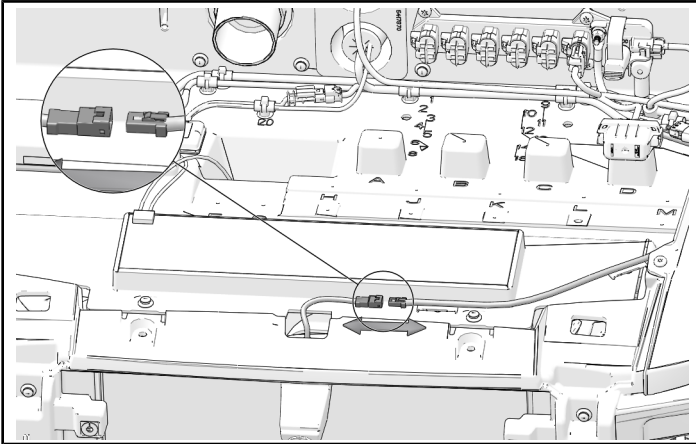

2. Remove and keep two push-pin rivets from front of underhood liner.

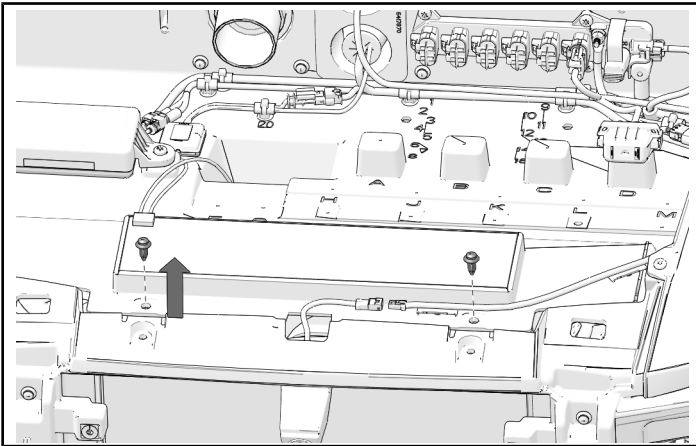

3. Lift front panel of underhood liner to access areas beneath.

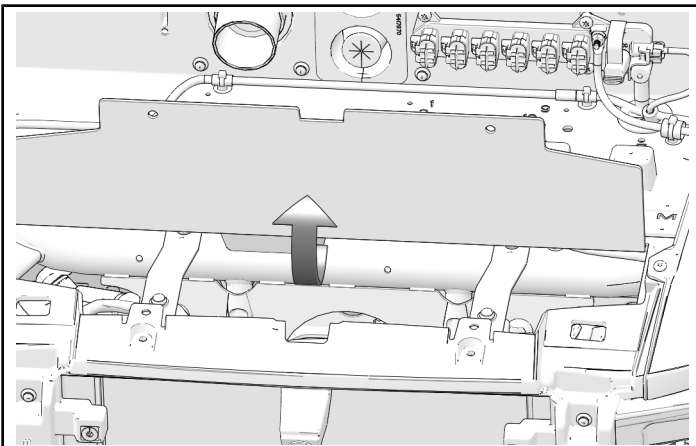

4. Remove harness clip from winch harness. Carefully cut zip tie from harness. Remove locator from hole in vehicle frame.

NOTICE

Underhood liner hidden for clarity.

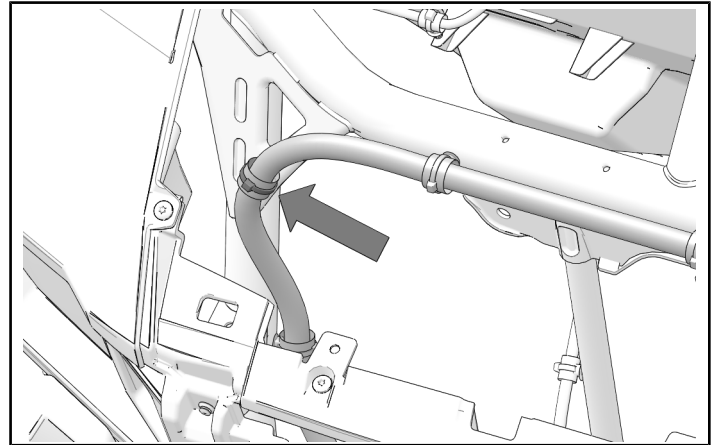

5. Install horn ③. Use screw ⑦, two washers ⑥, and nut ⑤ to attach horn to hole in frame. Torque nut to specification.

TORQUE

Nut ⑤:
97 in-lbs (11 N·m)

NOTICE

Winch harness hidden for clarity.

NOTICE

Screw ⑦ installs through hole which previously held harness clip. Put horn midway between adjacent frame members.

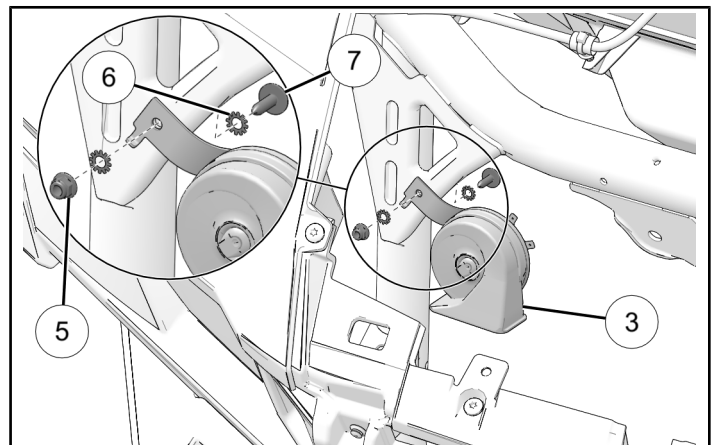

6. Install edge clip ① to winch harness. Attach edge clip to horn ③ bracket.

NOTICE

Underhood liner hidden for clarity.

NOTICE

Attach cable tie loosely to wiring harness until clip is fully seated on bracket. Then fully tighten cable tie.

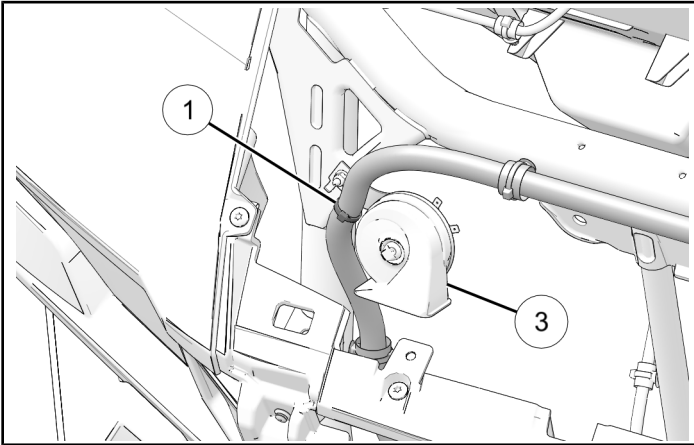

7. Attach wiring harness ② to horn terminals.

NOTICE

Underhood liner hidden for clarity.

NOTICE

Each wire can attach to either terminal on horn.

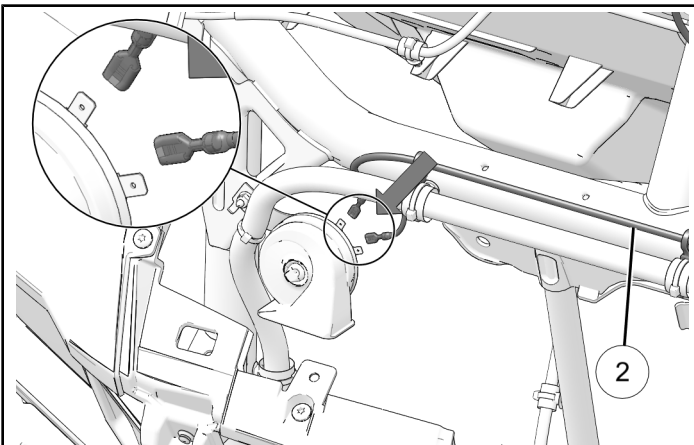

8. Route horn harness ② alongside existing winch harness. Attach four harness cable ties to winch harness near locations where winch harness attaches to frame.

NOTICE

Underhood liner hidden for clarity.

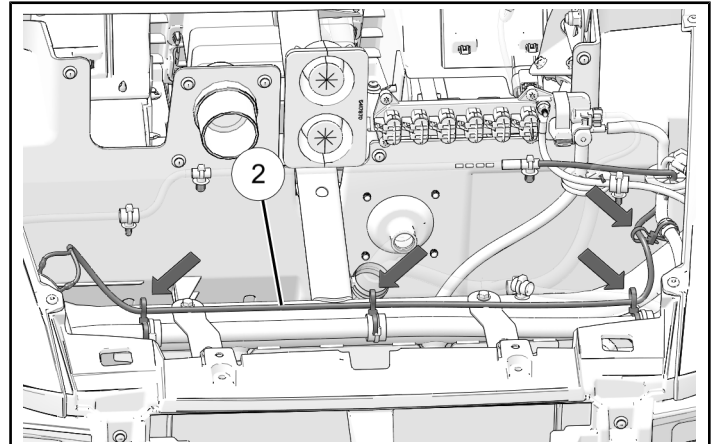

9. Route harness ② through leftmost grommet in underhood liner.

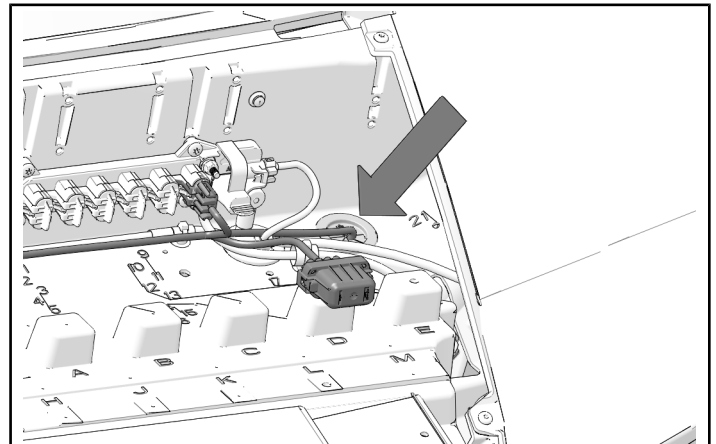

10. Route switch connector through upper grommet at back of underhood liner.

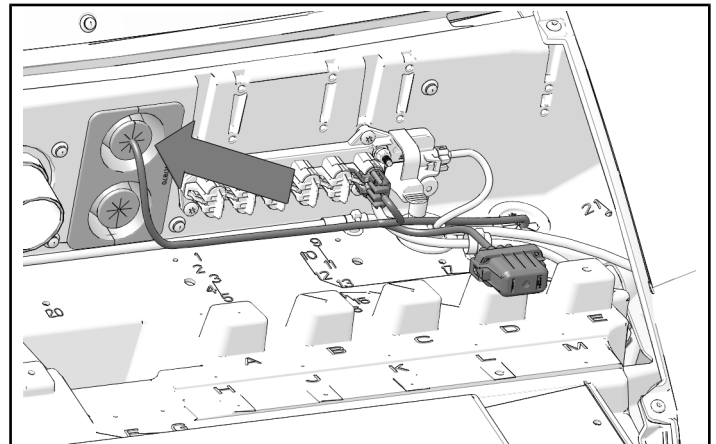

11. Reconnect front camera to harness.

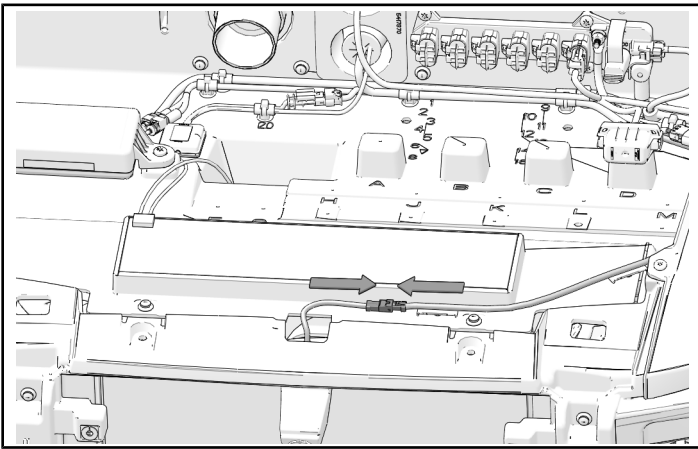

12. Drill hole through dimple at location D in underhood liner.

MEASUREMENT

Drill bit: 1/4 in (7 mm)

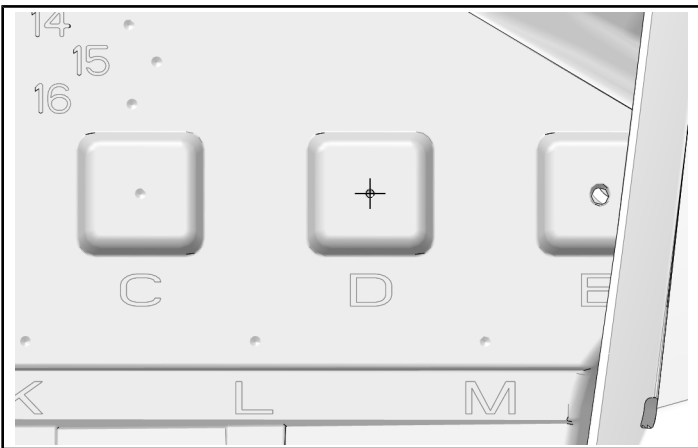

13. Push connector for fuse block into hole at location D marked on underhood liner.

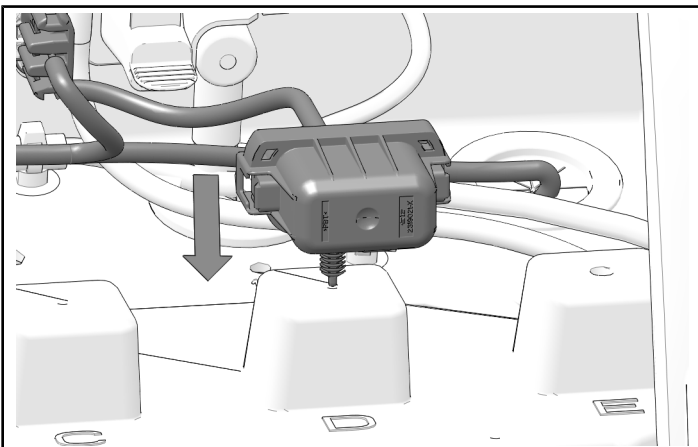

14. Connect harness ② to Pulse® Bar.

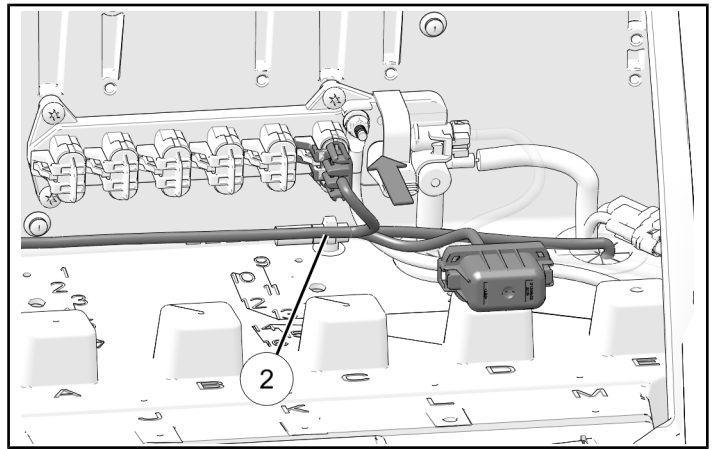

15. Install two push-pin rivets at front of underhood liner.

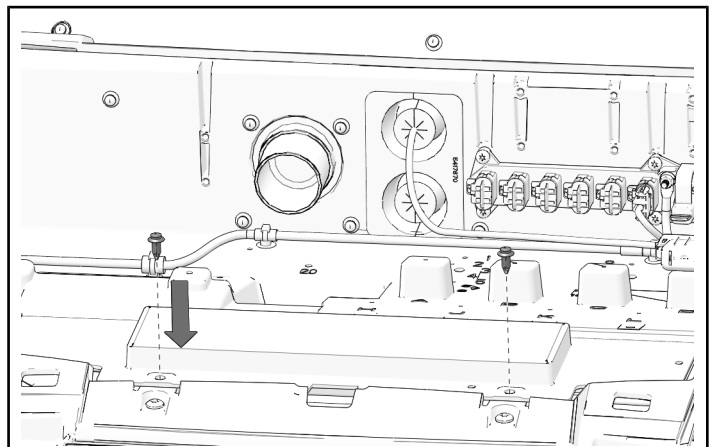

16. Remove switch cover from dash.

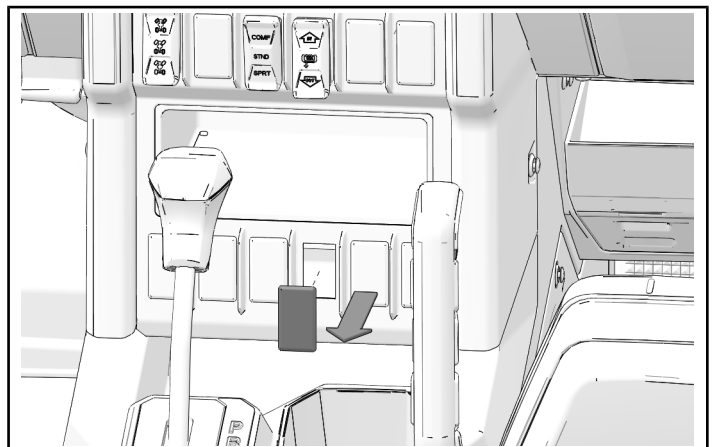

17. Pass harness ② switch connector through opening.

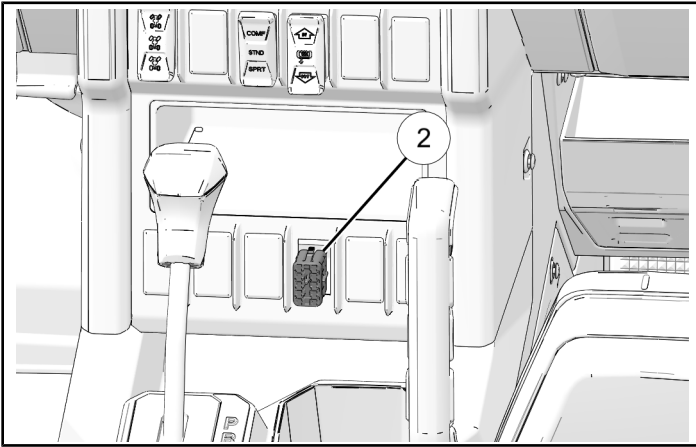

18. Attach switch ④ to harness ②.

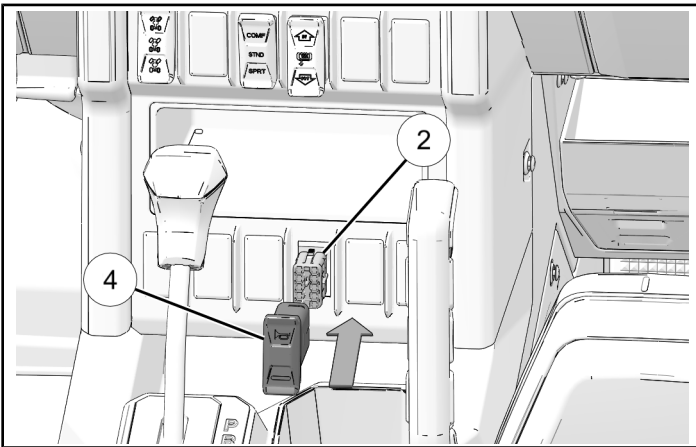

19. Install switch ④. Push switch into opening until switch clicks into place.

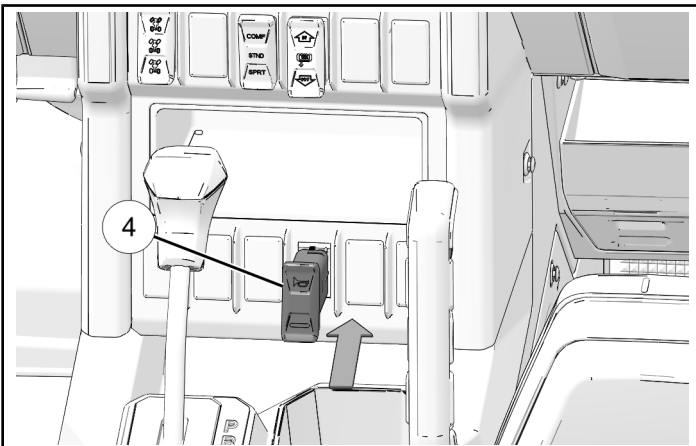

20. Test switch for proper function. Ignition switch must be in ON position. Horn will sound when switch is pressed.

VEHICLE REASSEMBLY

HEAD UNIT INSTALLATION

NOTICE

Base audio head unit installation shown. Ride Command® display installation similar.

1. Attach wiring harness and antenna to head unit.

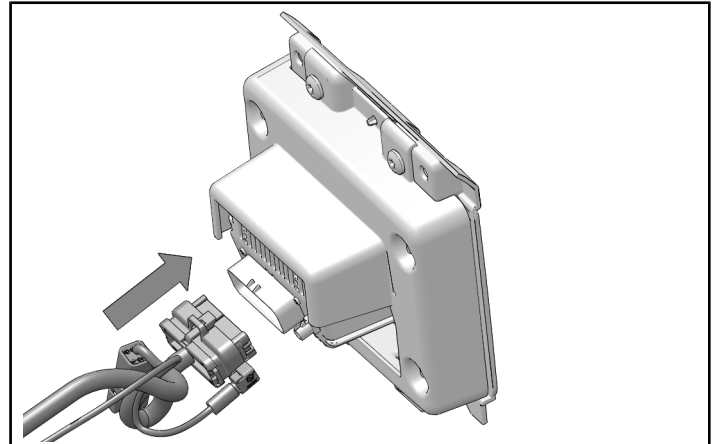

2. Put bottom of head unit into position. Push top of head unit into dash.

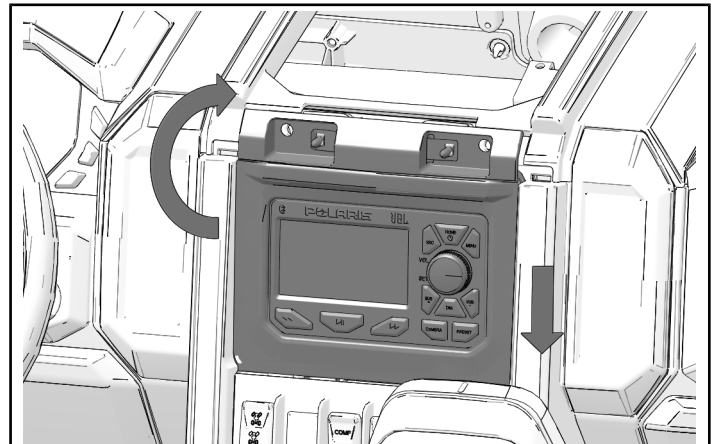

3. Install two push-pin rivets into top of head unit.

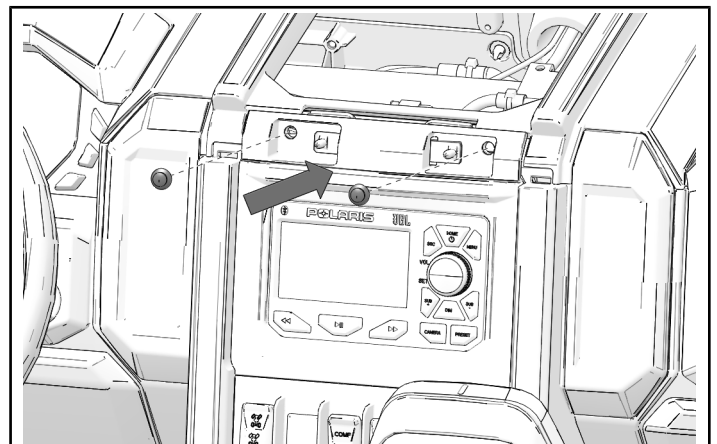

CENTER DASH PANEL INSTALLATION

1. Install center panel. Install rear tabs into dash, then lower into position.

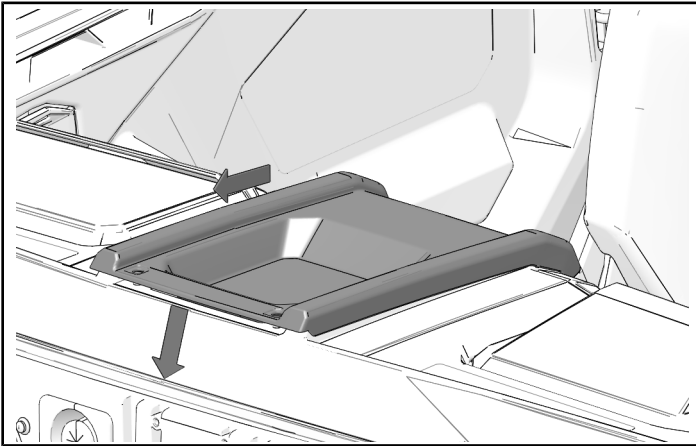

2. Install two push-pin rivets.

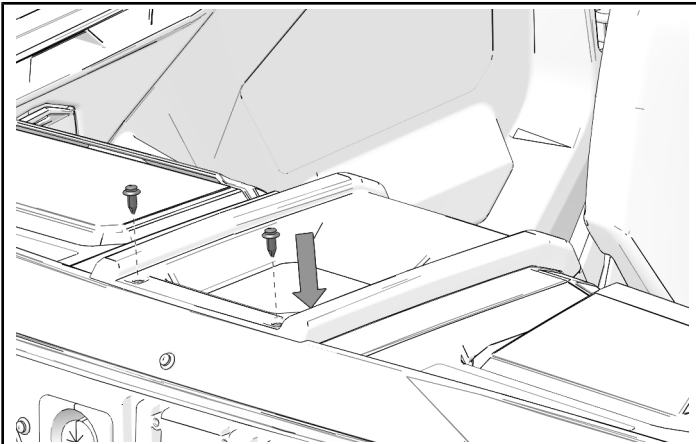

3. If vehicle is equipped with tip-out windshield. Install base, three screws, and washers. Torque screws to specification.

TORQUE

Base Screws:
89 in-lbs (10 N·m)

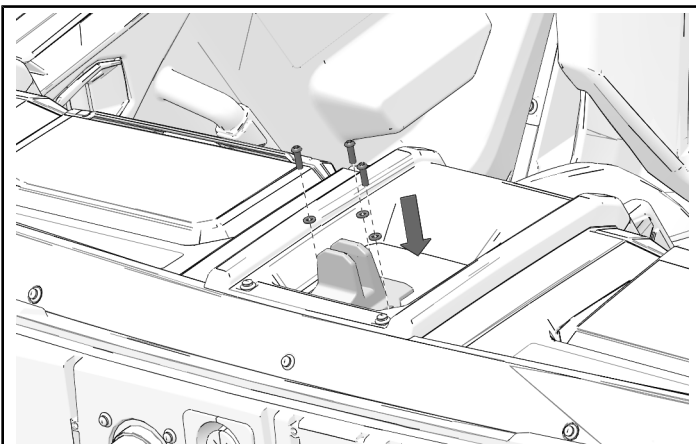

HOOD AND GRILL INSTALLATION

1. Put tabs on hood through openings in underhood liner. Then lower hood into position.

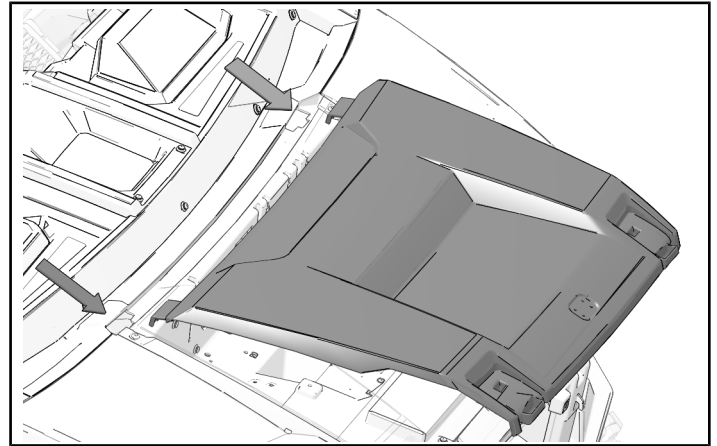

2. Pull rubber straps down over hooks to secure hood.

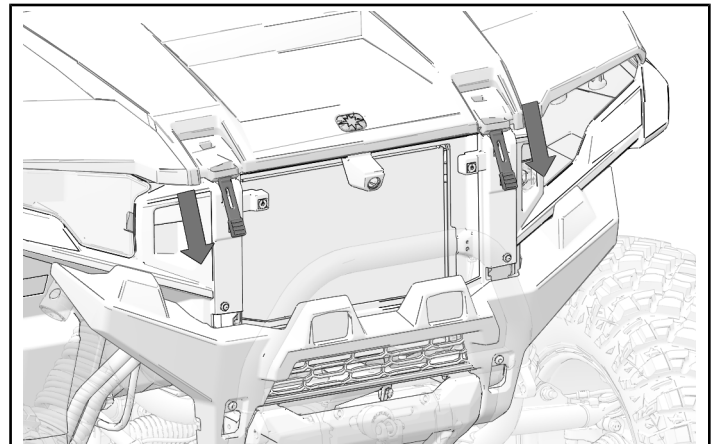

3. Put tabs on grill through openings in front fascia. Push top of grill into correct position.

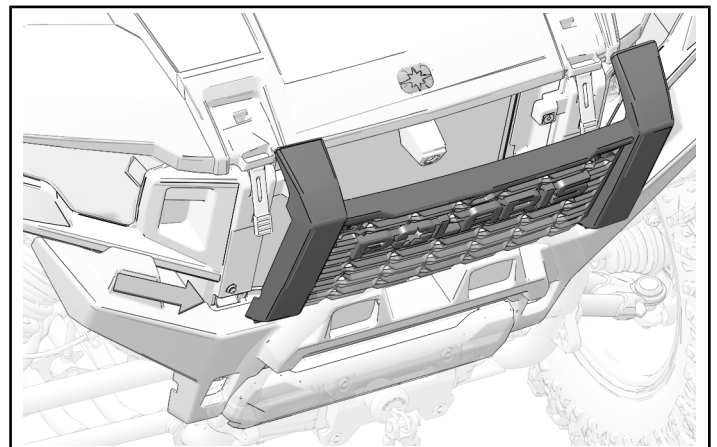

4. Push each stud in and turn one-quarter turn clockwise to attach grill.

