

PULSE™ 6 KIT



P/N 2884183

APPLICATION

Verify accessory fitment at Polaris.com.

BEFORE YOU BEGIN

Read these instructions and check to be sure all parts and tools are accounted for. Please retain these installation instructions for future reference and parts ordering information.

KIT CONTENTS

This Kit includes:

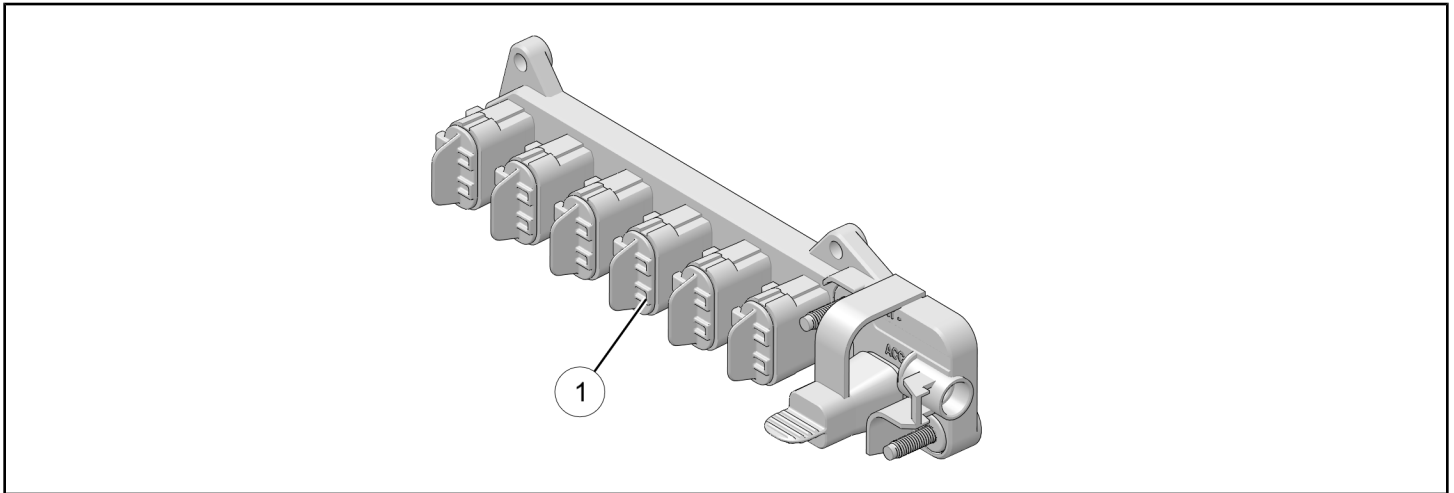

REF	QTY	PART DESCRIPTION	PART NUMBER
1	1	Terminal Block, Pulse™ 6	-
	1	Instructions	9929626

TOOLS REQUIRED

- Safety Glasses
- Screwdriver Set, Torx®
- Socket Set, Metric
- Torque Wrench
- Wrench Set, Metric

IMPORTANT

Your Pulse™ 6 Kit is exclusively designed for your vehicle. Please read the installation instructions thoroughly before beginning. Installation is easier if the vehicle is clean and free of debris. For your safety, and to ensure a satisfactory installation, perform all installation steps correctly in the sequence shown.

INSTALLATION INSTRUCTIONS

REMOVE EXISTING TERMINAL BLOCK

1. Shift vehicle transmission into "PARK". Turn ignition switch to "OFF" position and remove key.

⚠ WARNING

Ensure red positive (+) battery terminal is **COMPLETELY COVERED** by protective boot. Accidental tool contact across both battery terminals will result in high current electrical arc, and may result in battery explosion. Death or serious personal injury may occur.

Black negative (-) cable **MUST** be disconnected from battery terminal. Failure to disconnect cable may result in electrical arc when installing connections at terminal block. Death or serious personal injury, or damage to vehicle or accessory, may occur.

2. Flip up passenger seat bottom and remove under-seat storage compartment. Disconnect black negative (-) cable from battery.
3. Remove hood.
4. Disconnect all accessory harness connectors plugged into existing terminal block.
5. Remove nut **(A)** from terminal block stud identified as "**BAT -**", then detach chassis ground cable. Retain nut.

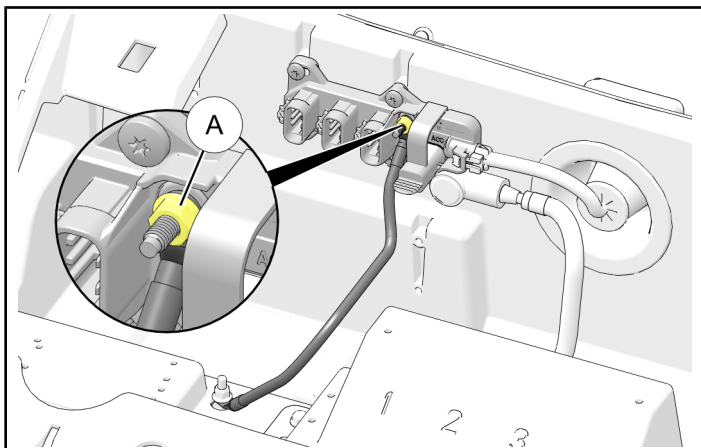

6. Slide red boot along "**T-BLOCK (B+)**" battery cable, remove nut **(B)** from terminal block stud identified as "**BAT +**", then detach battery cable. Retain nut.

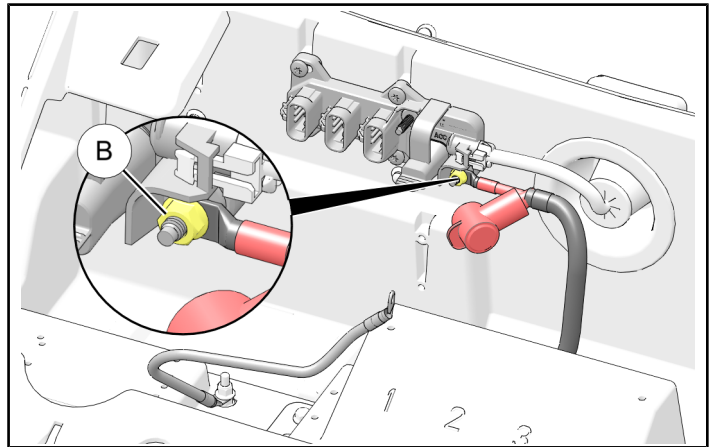

7. Detach harness connector **(C)** from terminal block connector identified as "**ACC**".

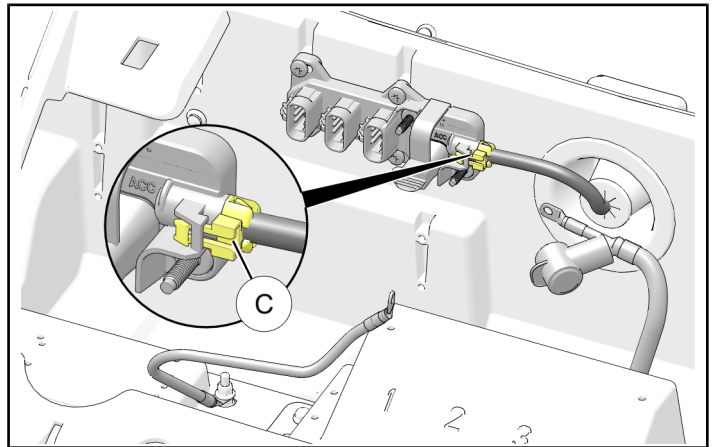

8. Remove four screws **(D)**, then remove terminal block. Retain screws. Terminal block will not be reused.

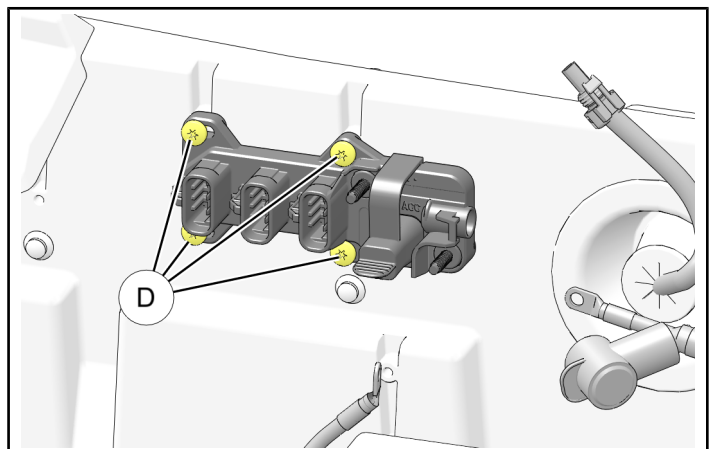

INSTALL NEW TERMINAL BLOCK

1. Install new terminal block ① to vehicle using four retained screws ④.

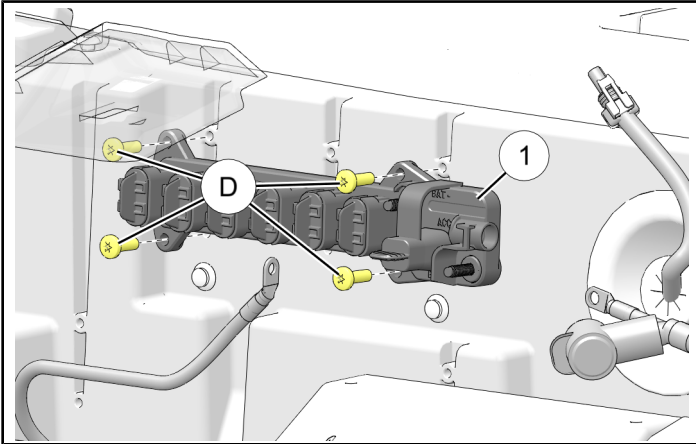

2. Join harness connector ③ to terminal block connector identified as “ACC”.

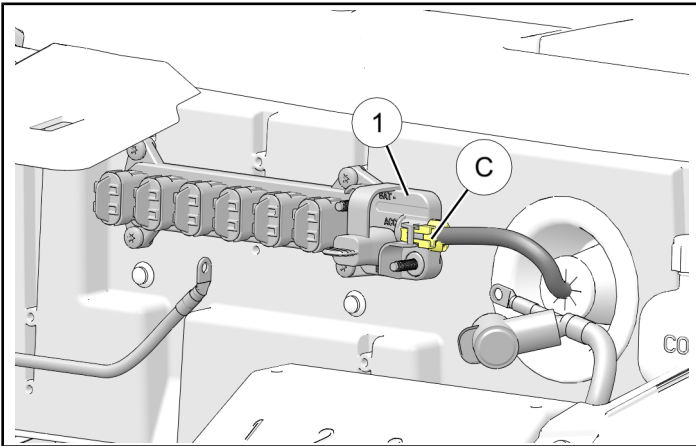

3. Install “T-BLOCK (B+)” battery cable to terminal block stud identified as “BAT +”, then reinstall nut ②. Torque nut to specification, then reposition red boot over stud.

TORQUE

31 in. lbs. (3.5 Nm) ± 10%

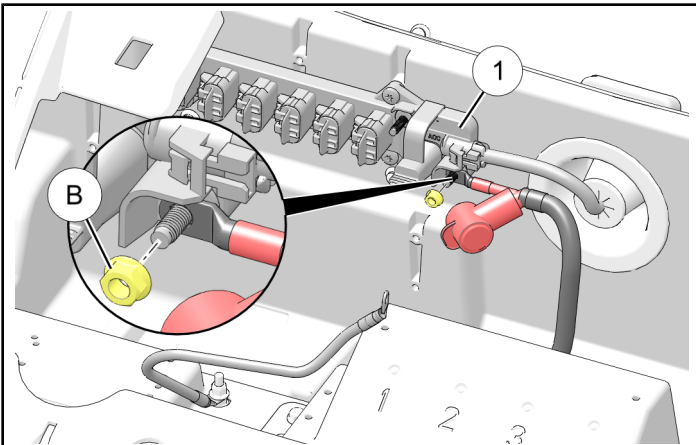

4. Install chassis ground cable to terminal block stud identified as “BAT -”, then reinstall nut ②. Torque nut to specification.

TORQUE

31 in. lbs. (3.5 Nm) ± 10%

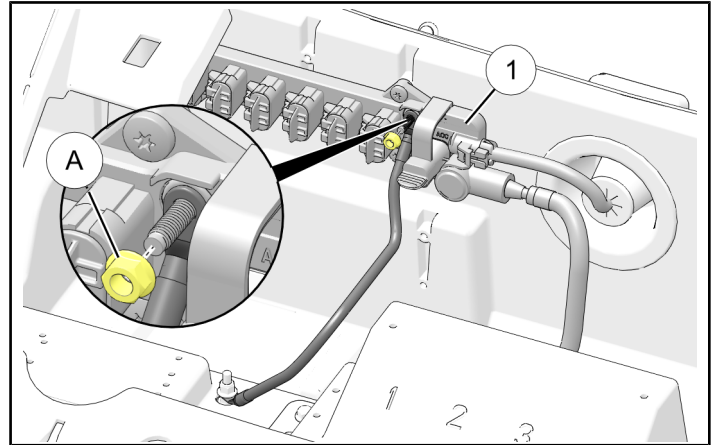

5. Reconnect accessory harness connectors to new terminal block ①.
6. Reconnect black negative (-) cable to battery, then reinstall under-seat storage compartment.
7. Reinstall hood.

FEEDBACK FORM

A feedback form has been created for the installer to provide any comments, questions or concerns about the installation instructions. The form is viewable on mobile devices by scanning the QR code or by clicking [HERE](#) if viewing on a PC.

