

HEATER KIT



P/N 2884066

APPLICATION

Verify accessory fitment at Polaris.com.

BEFORE YOU BEGIN

Read these instructions and check to be sure all parts and tools are accounted for. Please retain these installation instructions for future reference and parts ordering information.

KIT CONTENTS

This Kit includes:

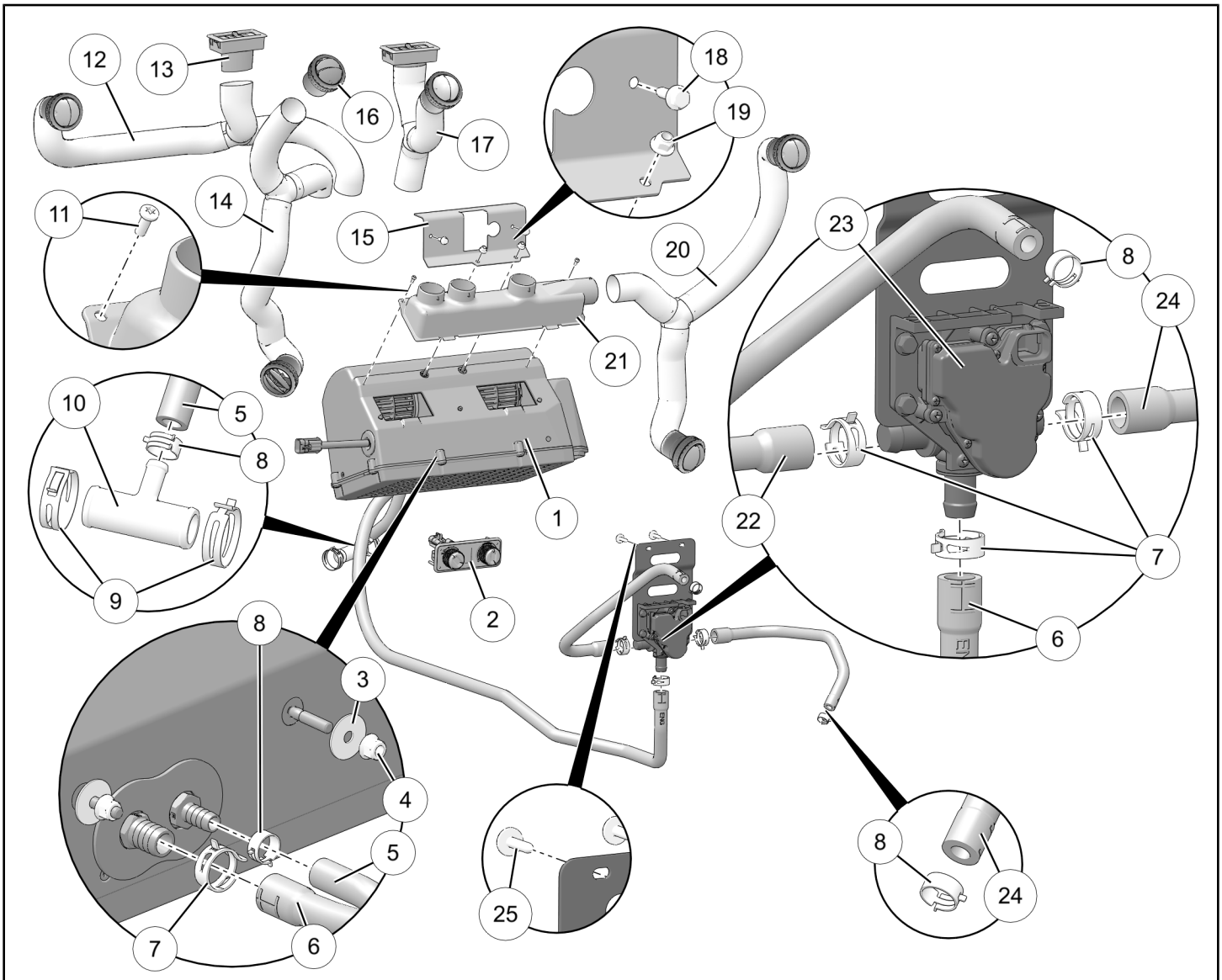

REF	QTY	PART DESCRIPTION	PART NUMBER
1	1	Core, Heater	2636739
2	1	Switch Panel	2413993
3	2	Washer, Flat - 0.328 X 1.25 X 16GA	7555716

REF	QTY	PART DESCRIPTION	PART NUMBER
4	2	Nut, Hex Flange, Locking - M8 X 1.25	7547332
5	1	Hose, Heater Core Outlet to Engine Return - 1/2 ID X 8.5 inches	5416358
6	1	Hose, 3-Way Valve Outlet to Heater Core Inlet	5417010
7	4	Clamp, Hose, Springband - 27/12 (Green)	7080841
8	4	Clamp, Hose, Spring	7081026
9	2	Clamp, Hose, Springband - 35/12 (Black)	7080844
10	1	Fitting, Tee - 1.0 X 1.0 X 0.5	7052530
11	2	Screw, Torx® Pan Head, High/Low - #10 X 1/2	7519091
12	1	Duct Assembly, LH Outboard Dash and LH Defrost	2636686
13	2	Vent, Rectangular (Defrost)	5453900
14	1	Duct Assembly, LH Inboard Dash and LH Footwell	2636684
15	1	Bracket, Core Mounting	5263841-329
16	6	Vent, Round	5452877
17	1	Duct Assembly, RH Inboard Dash and RH Defrost	2636687
18	2	Screw, Hex Flange - M6 X 1.0 X 20	7518529
19	2	Nut, Hex Flange, Locking - M6 X 1.0	7547339
20	1	Duct Assembly, RH Outboard Dash and RH Footwell	2636685
21	1	Manifold, Heater	5453899
22	1	Hose, Engine Oil Cooler Outlet to 3-Way Valve Inlet	5417211
23	1	Valve Assembly (includes items 23.1-23.2)	-
23.1	1	- Valve, 3-Way	2415244
23.2	4	- Screw, Hex Flange - M6 X 1.0 X 16	7518187
24	1	Hose, 3-Way Valve Outlet to Engine Water Pump Inlet	5417212
25	2	Screw, Torx® Truss Head - M6 X 1.0 X 25	7519650
26	1	Harness, Heater (not shown)	2414867
27	1	Cable Tie, Double (not shown)	7081807
28	30	Cable Tie (not shown)	7080761
29	1	Cover, Lower Storage Compartment (not shown)	5454155-070
	1	Instructions	9929385

TOOLS REQUIRED

- Safety Goggles
- Drill
- Drill Bit: 1/4 inch (6 mm)
- Drain Pan
- Hole Saw: 1-1/4 inch (32 mm), 2-1/2 inch (64 mm)
- Pliers, Hose Pinch-Off (three required)
- Pliers, Slip Joint
- Pliers, Side Cutting
- Pliers, Push Pin Rivet
- Cutting Tool
- Screwdriver Set, Torx®
- Socket Set, Metric
- Socket Set, SAE

CONSUMABLES REQUIRED

- Antifreeze, POLARIS 50/50 Premix, 2-4 quarts
- Gloves, Chemical Resistant

IMPORTANT

Your Heater Kit is exclusively designed for your vehicle. Please read the installation instructions thoroughly before beginning. Installation is easier if the vehicle is clean and free of debris. For your safety, and to ensure a satisfactory installation, perform all installation steps correctly in the sequence shown.

HARNESS DETAIL

SWITCH PANEL ②:

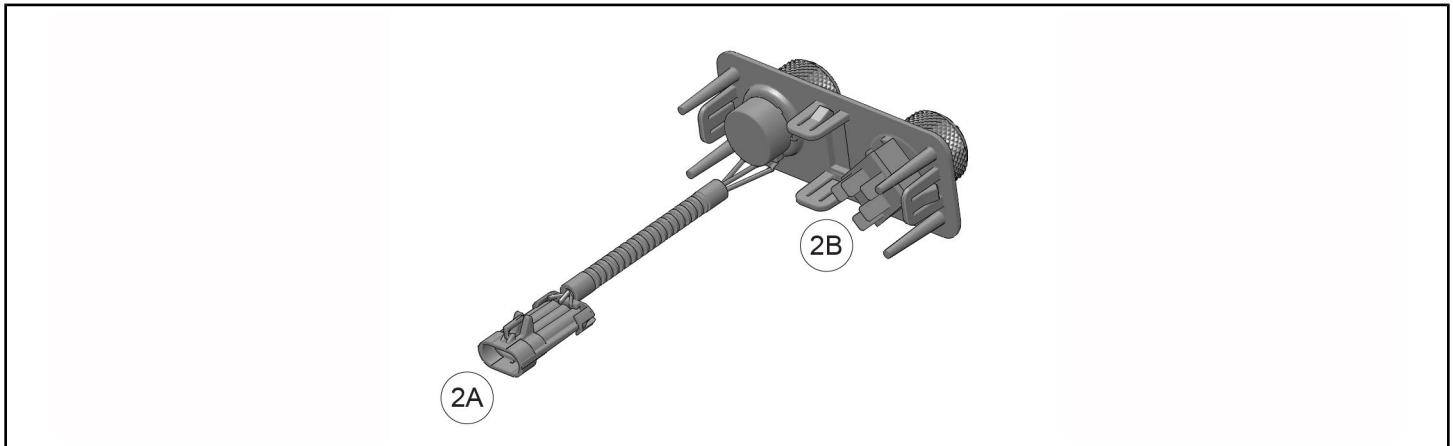

REF	PART DESCRIPTION	WIRE COLOR	PIN QTY/ GENDER	CONNECTS TO
2A	Connector, Temperature Control	-	3 male	Heater harness ②⑥, connector 26G
2B	Connector, Blower Control	-	5 male	Heater harness ②⑥, connector 26H

HEATER HARNESS ②⑥:

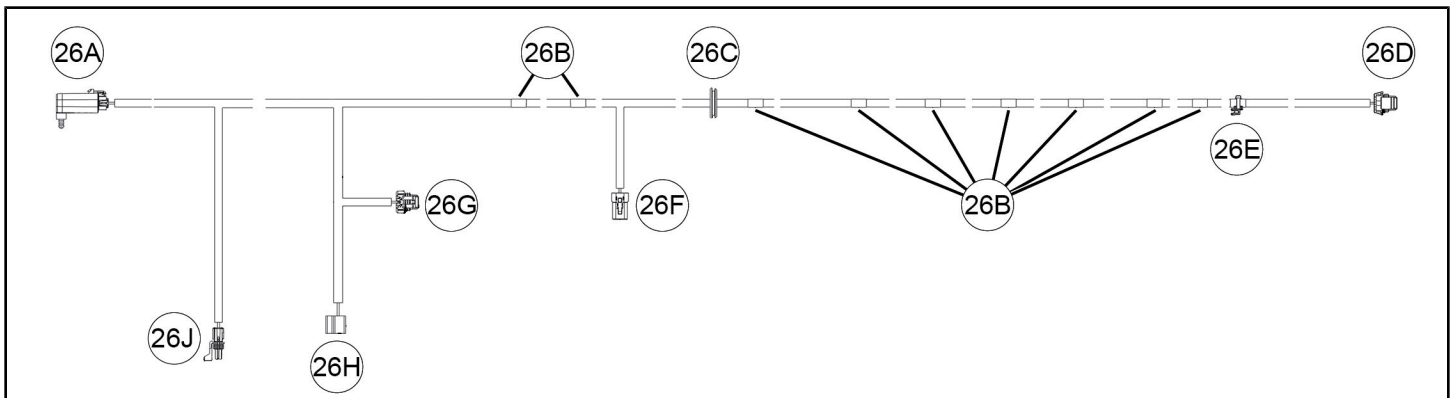

REF	PART DESCRIPTION	WIRE COLOR	PIN QTY/ GENDER	CONNECTS TO
26A	Relay/Fuse Block	-	-	Vehicle structure
26B	Tape, White (9 places)	-	-	Nothing; identifies locations where harness is secured using cable ties ②⑧
26C	Grommet	-	-	Vehicle structure
26D	Connector, 3-Way Valve	-	6 female	Valve assembly ②③
26E	Clip, Edge	-	-	Vehicle structure
26F	Connector, Blower Motor	-	4 female	Heater core ①
26G	Connector, Temperature Control	-	3 female	Switch panel ②, connector 2A
26H	Connector, Blower Control	-	5 female	Switch panel ②, connector 2B
26J	Connector, Terminal Block	-	3 female	Vehicle terminal block

COOLANT FLOW DETAIL

Coolant flow through the installed heater core is shown.

- **Heater OFF:** Coolant flows from oil cooler (A) through hose (22) into LH side of valve (23). Coolant passes straight through valve and out RH side, then flows through hose (24) back to water pump (B). No coolant flows through hose (6), core (1), or hose (5).
- **Heater ON:** Coolant flows from oil cooler (A) through hose (22) into LH side of valve (23). Coolant is diverted out bottom of valve, then flows through hose (6) to core (1), through core and out hose (5), then back to water pump (B). No coolant flows through hose (24).

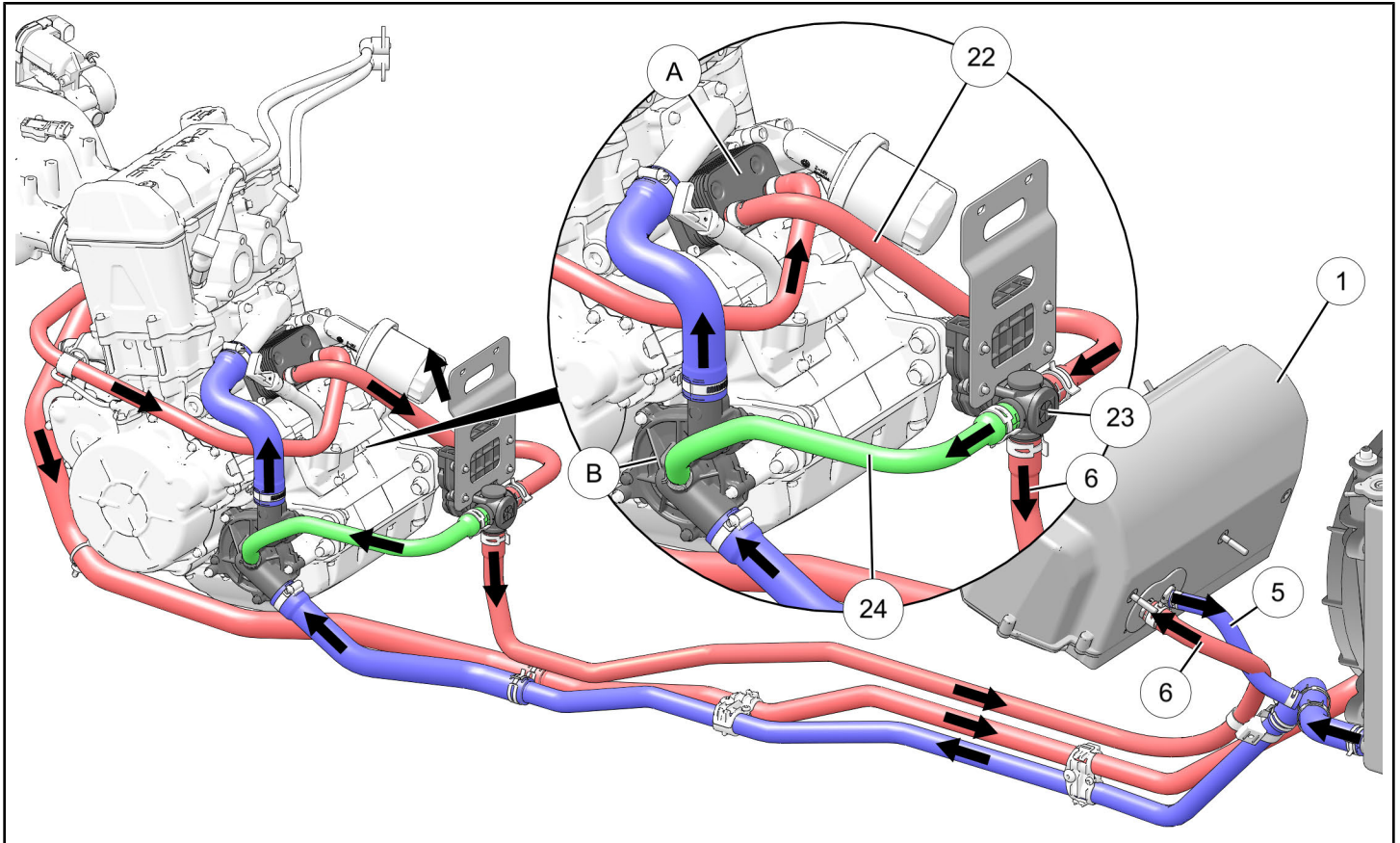

INSTALLATION INSTRUCTIONS

PREPARE VEHICLE FOR INSTALLATION

NOTE

Polaris recommends two people assemble and install this kit.

⚠ WARNING

Ensure red positive (+) battery terminal is COMPLETELY COVERED by protective boot. Accidental tool contact across both battery terminals will result in high current electrical arc, and may result in battery explosion. Death or serious personal injury may occur.

1. Shift vehicle transmission into "PARK". Turn ignition switch to "OFF" position and remove key.
2. Flip up passenger seat bottom and remove underseat storage compartment. Disconnect black negative (-) cable from battery.
3. Remove hood.
4. If windshield is installed, remove or open (as applicable) to gain access to upper dash.

5. Remove upper dash cupholder by removing two push pin rivets (A), then slide cupholder rearward. Retain rivets.

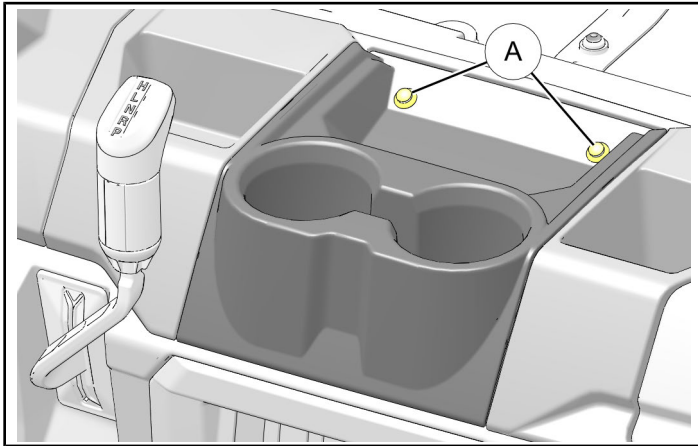

- c. Open door to upper storage compartment. Remove three push pin rivets (D) from RH side of dash: two inside storage compartment and one on underside of dash above cupholder.

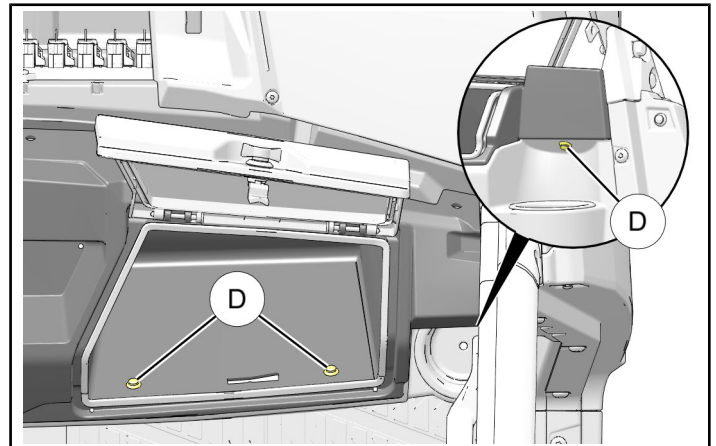

6. Remove upper dash.

- a. Remove six push pin rivets (B) along forward edge of dash.

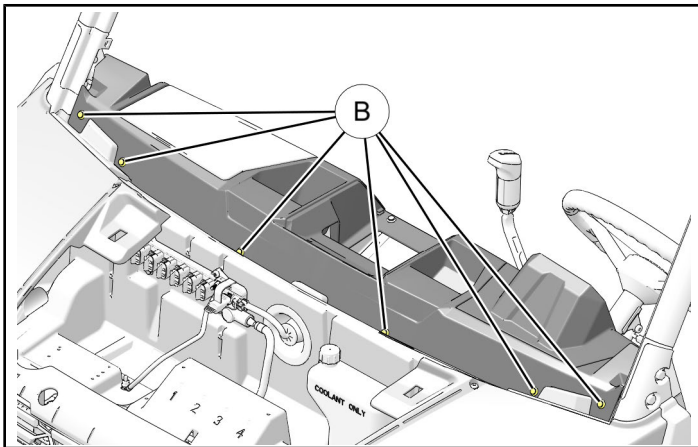

- b. Remove five push pin rivets (C) from LH side of dash: two at center cupholder, two below instrument cluster, and one on underside of dash above cupholder.

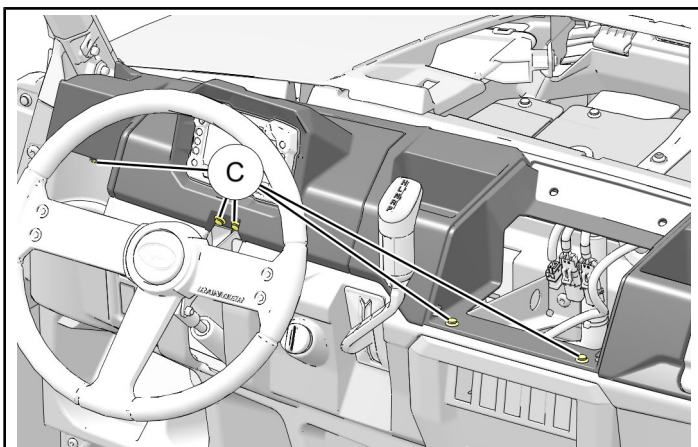

- d. Remove upper dash from vehicle.

7. Remove control panel.

- a. Remove two push pin rivets (E) from lower face of control panel. Retain rivets.

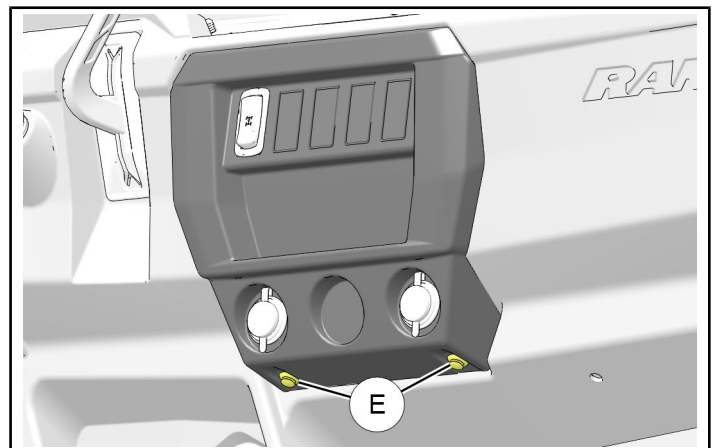

- b. Rotate bottom of control panel rearward, disengaging two side tabs (F), then drop two upper tabs (G) out of slots in main dash panel.

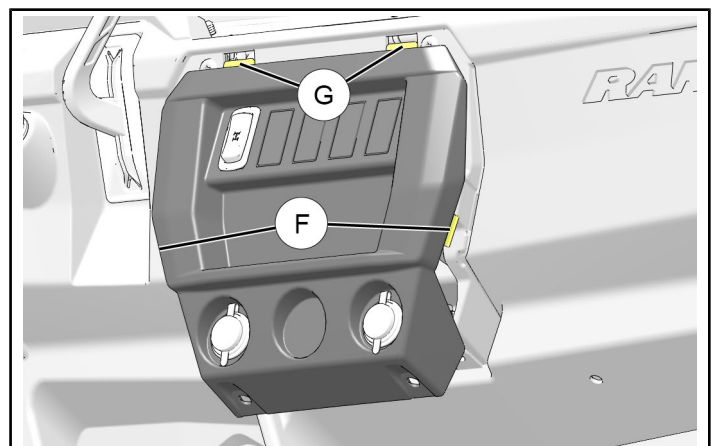

- c. Label and disconnect electrical harnesses from switches, sockets, or other devices in control panel.

8. Remove lower storage compartment by removing six push pin rivets (H). Retain rivets (two rivets will be reused later to install new cover). Storage compartment will not be reused.

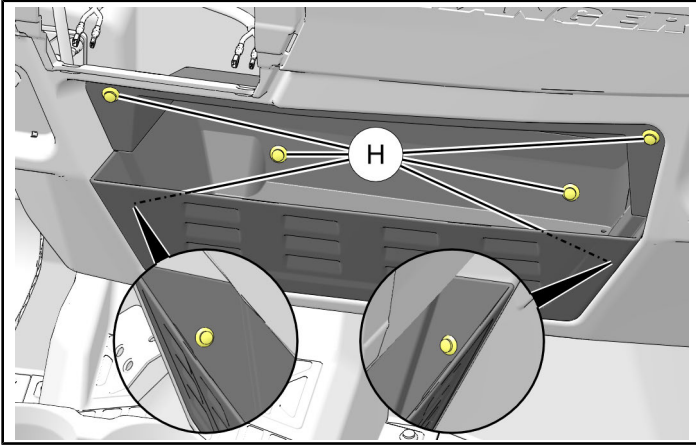

9. Remove screw (J), then pull off shift lever grip. Retain screw and grip.

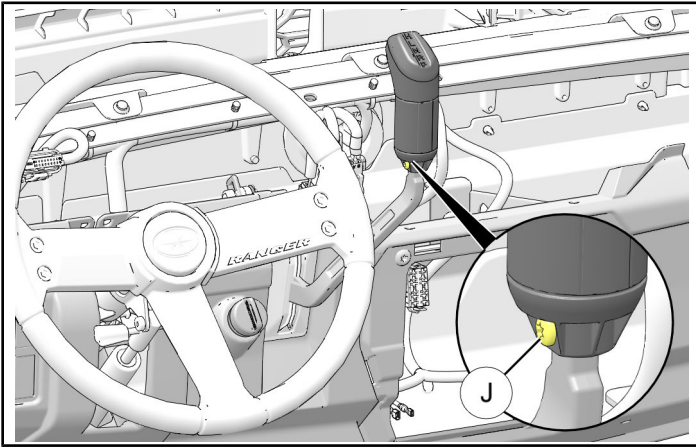

10. Remove lower dash by removing the following:

- Four M6 screws (K)
- Four M8 screws (L) (with net buckles)
- Four #14 high-low screws (M)

Retain all fasteners and buckles.

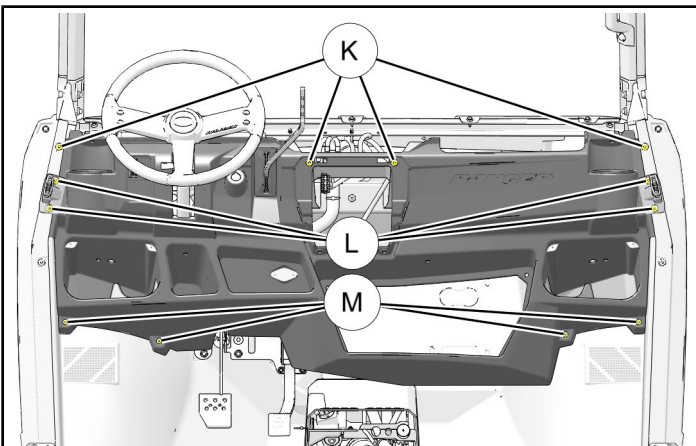

11. Remove three push pin rivets (N) from each side of center floor console.

Lift back of console, disengage tab from front, then remove console from vehicle. Retain rivets.

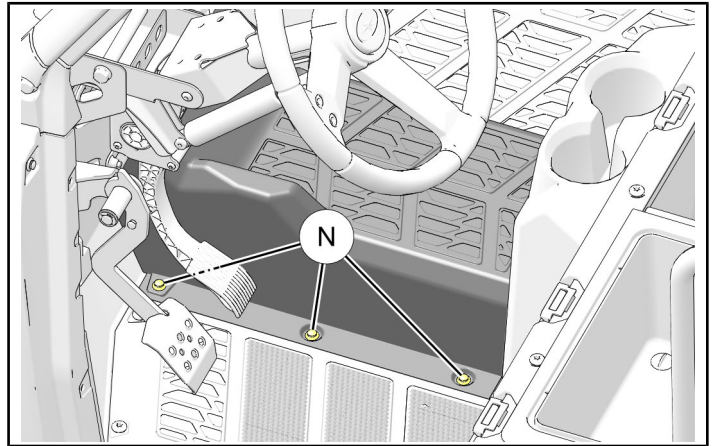

INSTALL HEATER CORE

1. Remove two screws (A), then remove dash support bracket (B). Also remove screw (C). Retain any two screws; the remaining screw will not be reused.

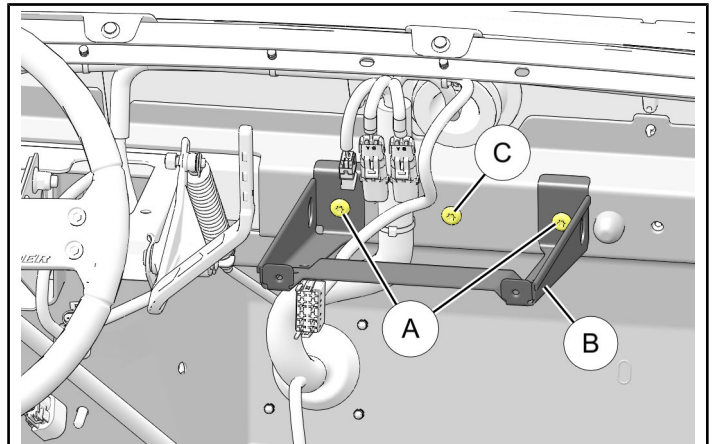

2. Insert two tabs (D) on lower edge of manifold (21) into slots on front side of core (1), then secure top edge of manifold to core using two screws (11). Tighten screws.

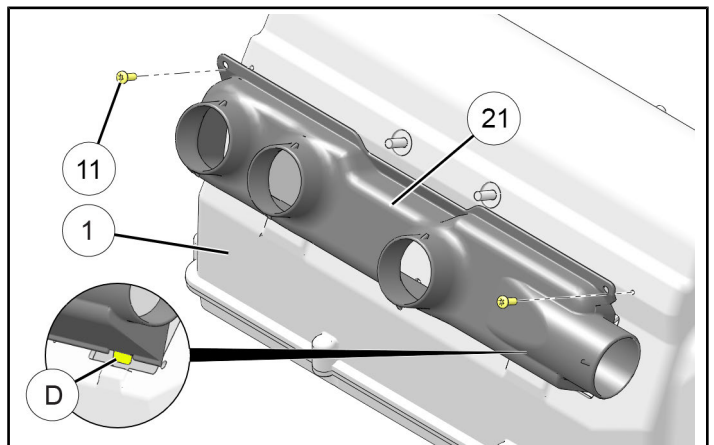

3. Cut out three marked openings in firewall:
 - Two vertical slots **E** for heater core mounting studs
 - One figure-eight shaped opening **F** for heater core hose fittings
 - One circular opening **G** for grommet 26C on heater harness **26**; use 1-1/4 inch (32 mm) hole saw centered on marked outline; drilled opening will be LARGER than marked outline

Debur openings.

IMPORTANT

Control cutting depth to prevent damage to underlying structure or components.

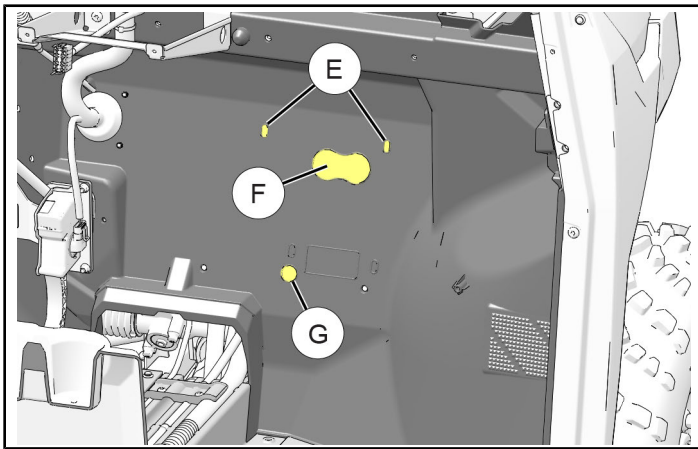

4. Lift heater core assembly **1** into position beneath dash, inserting two front studs **H** through vertical slots **E** in firewall. Loosely install two each washers **3** and nuts **4**.

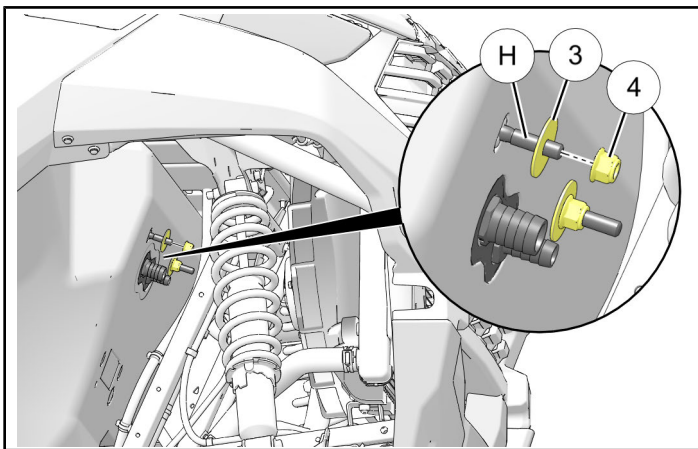

5. Install core mounting bracket **15** over heater core upper studs **J**, then install bracket to firewall structure using two screws **18**. Tighten screws.

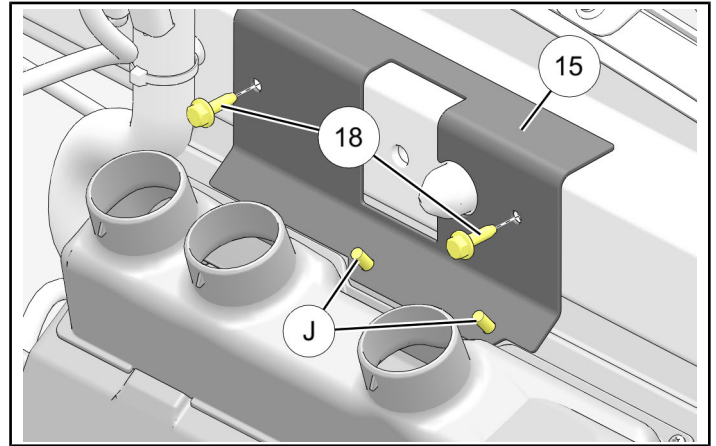

6. Secure heater core upper studs **J** to core mounting bracket **15** using two nuts **19**. Tighten nuts.

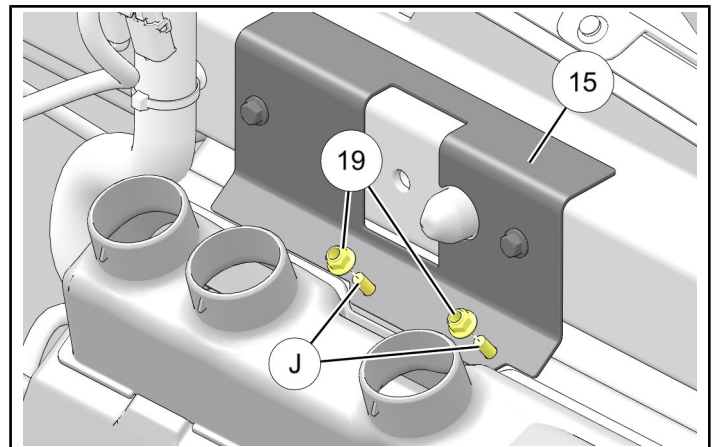

7. Tighten two firewall nuts **4** installed in Step 4 of this section.

NOTE

Do not reinstall dash support bracket **B** at this time.

INSTALL HARNESS

NOTE

See previous section, **HARNESS DETAIL**, for connector identification.

1. Route all connectors on heater harness ②⑥, EXCEPT relay/fuse block connector 26A and terminal block connector 26J, rearward through firewall grommet ① into upper dash compartment.

NOTE

Grommet may be temporarily removed to facilitate harness passage.

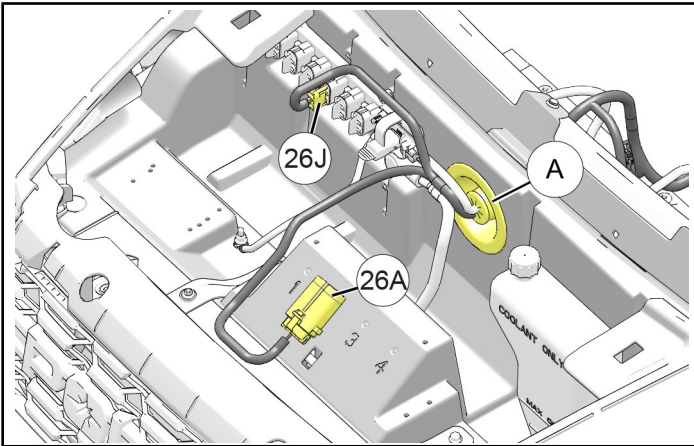

2. Drill out one accessory plug (1/4 inch / 6 mm) on under-hood liner, then install relay/fuse block 26A using attached fir tree clip.

IMPORTANT

Control drill depth to prevent damage to underlying structure or components.

3. Open power cap on vehicle terminal block at any open location, then plug in connector 26J.
4. Route connectors 26G and 26H rearwards towards control panel opening for later connection to heater switch panel ②.

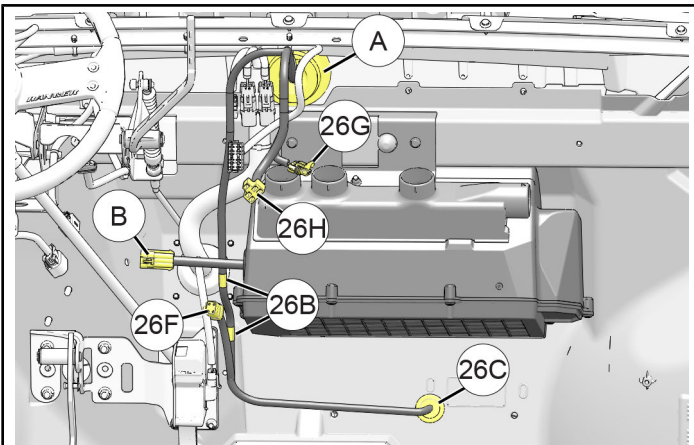

5. Route connector 26F downward, then join to connector ② exiting LH side of heater core ①.
6. Route 3-way valve connector 26D forward through drilled firewall hole (see previous section, **INSTALL HEATER CORE**, Step 3), then install grommet 26C in hole.

Secure with two cable ties ②⑧ at (or near) white tape locations 26B to prevent contact with hot components, sharp edges, or moving parts.

7. Route heater harness ② downwards towards center floor console, then rearward into console as shown.

Secure heater harness to main chassis harness using cable tie ②⑧ at (or near) white tape location 26B to prevent contact with hot components, sharp edges, or moving parts.

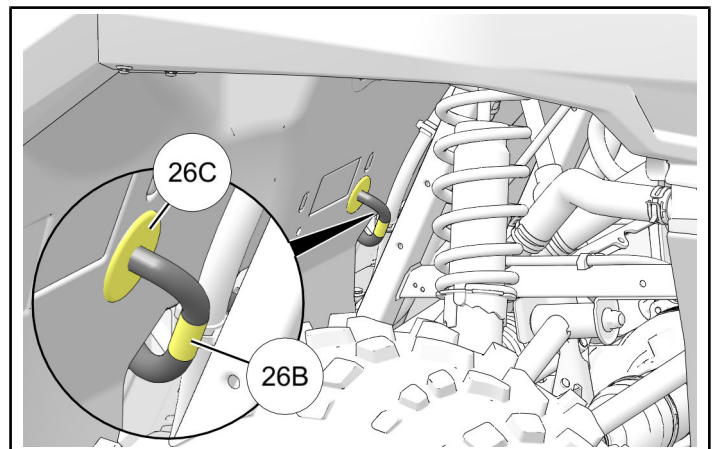

- Continue routing connector 26D rearward through center console. Ensure harness is routed to prevent contact with hot components, sharp edges, or moving parts, but do not secure harness at this time.

NOTE

Observe six white tape locations 26B and edge clip 26E. These will be used to secure harness in a later step.
 Connector 26D will be joined to 3-way valve assembly ② in a later step.

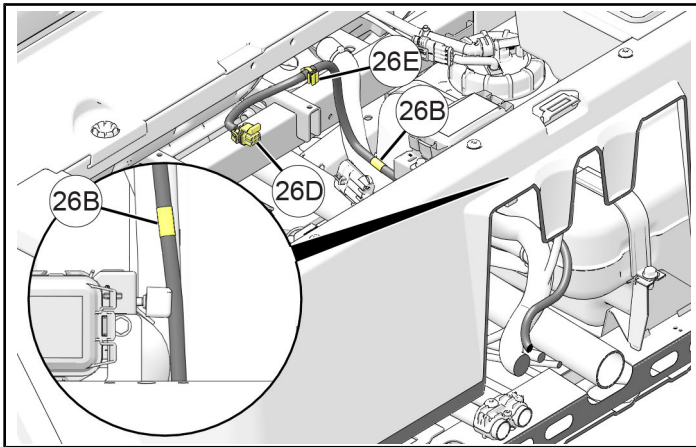
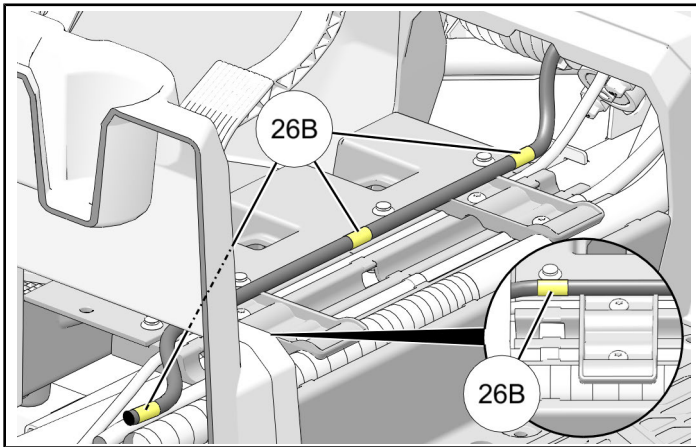

INSTALL DUCT ASSEMBLIES

- UPPER DASH PANEL:** Cut one driver side rectangular DEFROST vent opening ① along INSIDE EDGE of recessed marking. Debur opening.

Repeat for passenger side of panel (two openings total).

NOTE

Passenger side vents shown installed for reference.

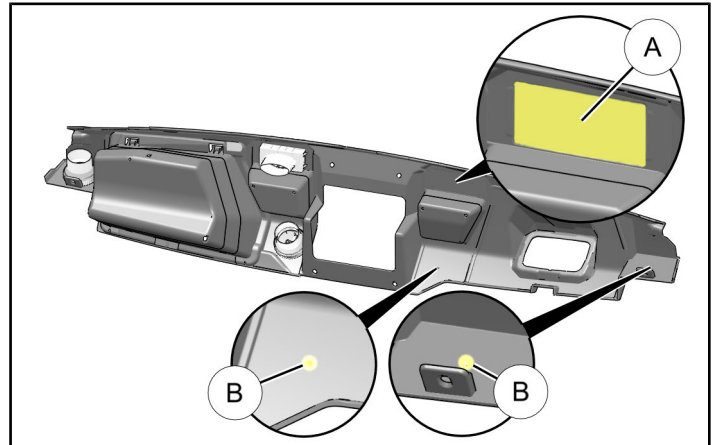

- UPPER DASH PANEL:** Cut two driver side round DASH vent openings ② using 2-1/2 inch (64 mm) hole saw, centered on existing markings.

Repeat for passenger side of panel (four openings total).

- LOWER DASH PANEL:** Cut two round FOOTWELL vent openings ③ using 2-1/2 inch (64 mm) hole saw, centered on existing markings.

NOTE

Driver side vent shown installed for reference.

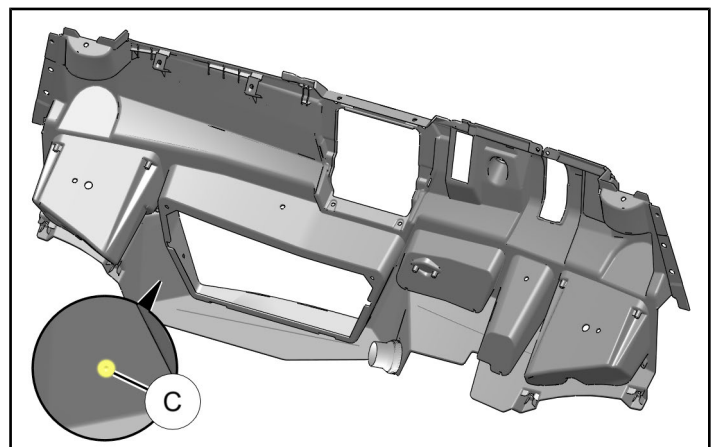

4. Install duct assembly 12 to SECOND outlet on manifold 21 (counting from LH to RH side) until duct contacts stop on manifold. Secure duct to manifold using cable tie 28.

NOTE

Steering wheel hidden in following steps for clarity.

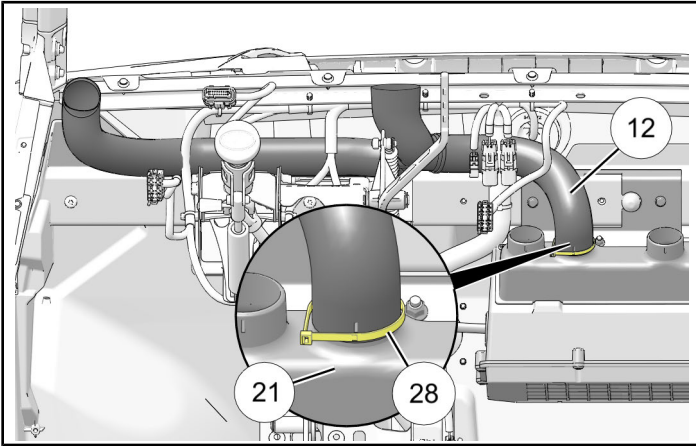

5. Install duct assembly 14 to FIRST outlet on manifold 21 until duct contacts stop on manifold. Secure duct to manifold using cable tie 28.

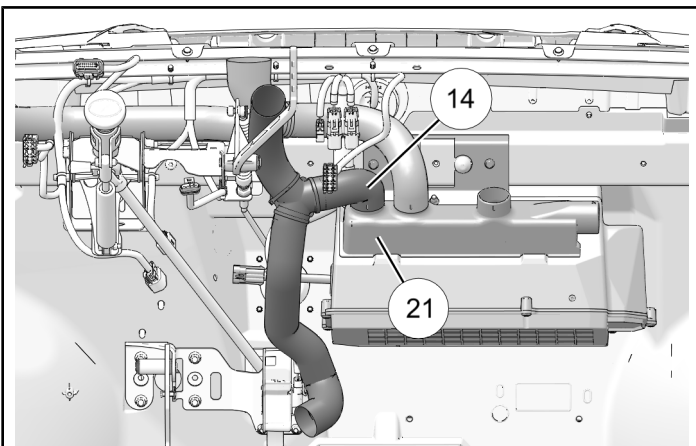

6. Install duct assembly 17 to THIRD outlet on manifold 21 until duct contacts stop on manifold. Secure duct to manifold using cable tie 28.

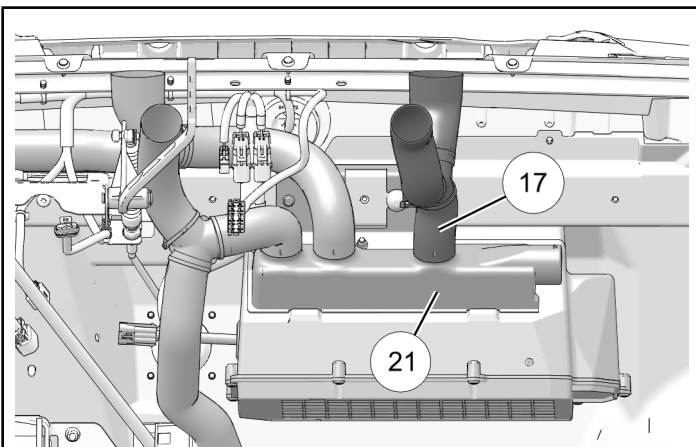

7. Install duct assembly 20 to FOURTH outlet on manifold 21 (RH side) until duct contacts stop on manifold. Secure duct to manifold using cable tie 28.

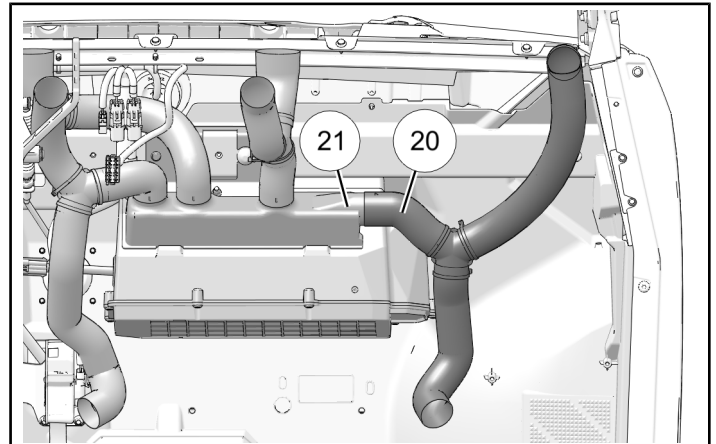

8. Reinstall dash support bracket D removed in previous section, **INSTALL HEATER CORE**, Step 1, using two retained screws E. Tighten screws.

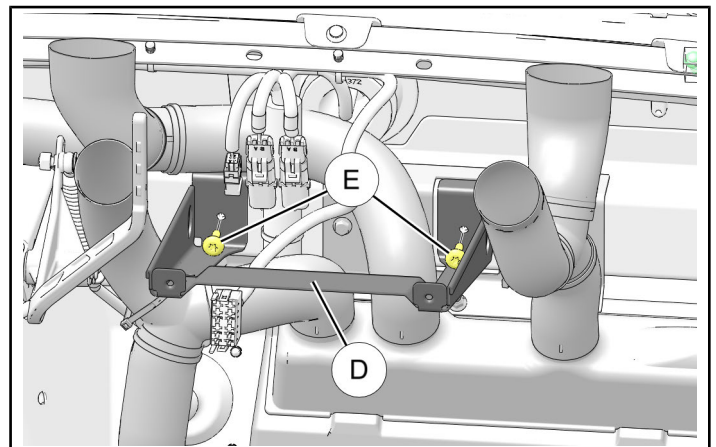

9. Install lower dash and footwell vents.

- a. Disassemble two round vents 16 by unscrewing vent outlet from vent body.
- b. Attach vent body to lower branch of RH duct 20 using cable tie 28. Repeat for LH duct 14.

- c. Reinstall lower dash using retained screws (F), (G), and (H). Also reinstall net buckles. See previous section, **PREPARE VEHICLE FOR INSTALLATION**, Step 10.

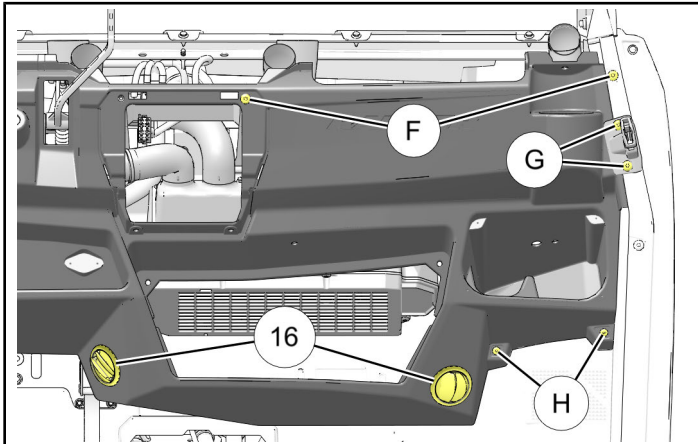

- d. Position footwell vent body (with attached duct) in dash opening, then thread vent outlet onto vent body. Repeat for opposite side.

10. Install upper dash and vents.

- a. Disassemble four round vents (16) by unscrewing vent outlet from vent body.
- b. Attach all four vent bodies to ROUND (occupant-facing) branches of ducts (12), (14), (17), and (20) using cable ties (28).
- c. Holding upper dash into position, push LH defrost duct (12) up through upper dash. Install rectangular vent (13), secure vent to duct using cable tie (28), then snap vent into defrost opening.

Repeat for RH side using RH defrost duct (17).

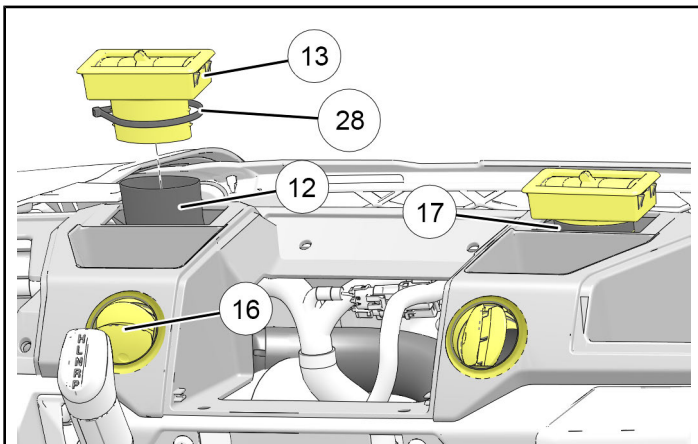

- d. Insert each of the four round vent bodies (with attached duct) into its corresponding dash opening, then thread vent outlet back onto vent body.

11. Reinstall shift lever grip using retained screw. See previous section, **PREPARE VEHICLE FOR INSTALLATION**, Step 9.
12. Reinstall upper dash. See previous section **PREPARE VEHICLE FOR INSTALLATION**, Step 6.

INSTALL CONTROL PANEL

1. Carefully cut out marked rectangular area (A) from control panel (visible on inside of panel). Debur opening.

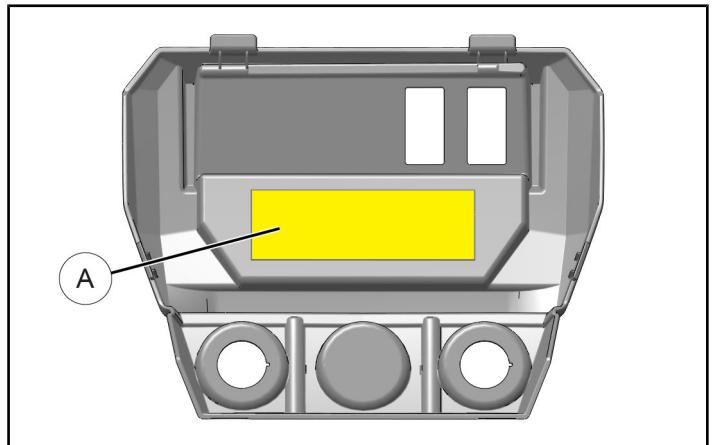

2. Orient switch panel (2) so blower control is on LH side and temperature control is on RH side, then install into opening until tabs lock in place.

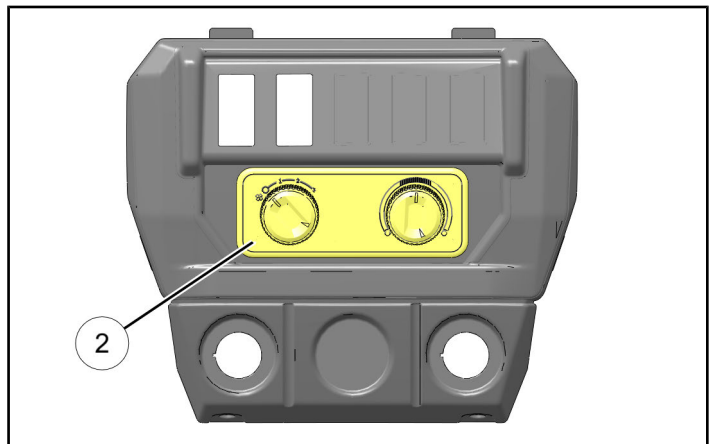

3. Join temperature control connector 2A on switch panel (2) to connector 26G on heater harness (26).
4. Join blower control connector 2B on switch panel (2) to connector 26H on heater harness (26).
5. Reconnect electrical harnesses disconnected in previous section **PREPARE VEHICLE FOR INSTALLATION**, Step 7, then reinstall control panel using two retained rivets.

INSTALL COOLING SYSTEM COMPONENTS

⚠ WARNING

Ensure red positive (+) battery terminal is **COMPLETELY COVERED** by protective boot. Accidental tool contact across both battery terminals will result in high current electrical arc, and may result in battery explosion. Death or serious personal injury may occur.

⚠ WARNING

Always wear safety goggles and proper shop clothing when performing this procedure. Failure to do so may result in severe injury or death.

⚠ WARNING

Ensure engine is **COOL** before performing the following steps. Hot cooling system will be pressurized, and opening system may result in uncontrolled release of hot coolant, resulting in severe burns or other injuries.

NOTE

See previous section, **COOLANT FLOW DETAIL**, for additional information.

1. Install 3-way valve assembly.
 - a. Join valve connector 26D on heater harness ②6 to 3-way valve ①A.

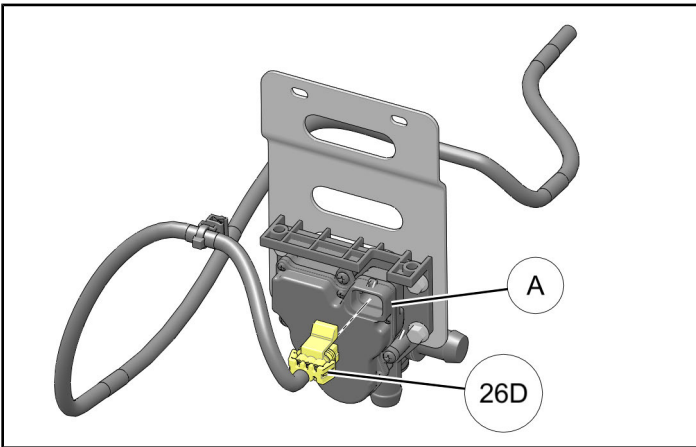

- b. Install valve assembly ②3 to seat support structure using two screws ②5. Tighten screws.

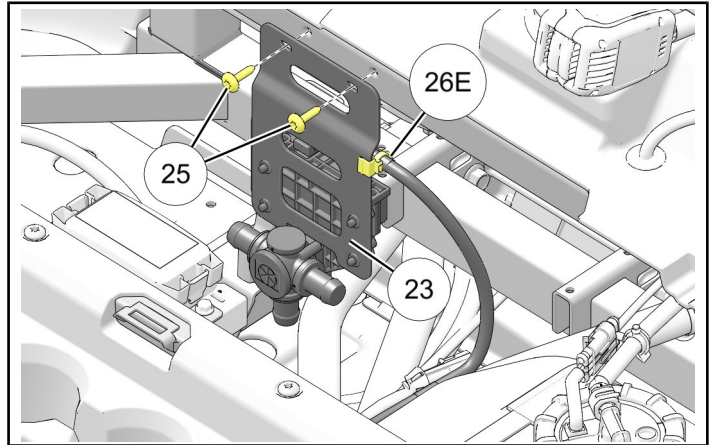

- c. Secure heater harness ②6 to valve assembly ②3 using edge clip 26E.
 - d. Secure heater harness ②6 to main chassis harness at six white tape locations 26B using cable ties ②8. See previous section, **INSTALL HARNESS**, Step 8.

Carefully examine all harness routing. Ensure harnesses are routed and secured to prevent contact with hot components, sharp edges, or moving parts. Use additional cable ties ②8 as required.

2. Install COLD RETURN heater hose to heater core outlet.
 - a. Assemble tee fitting ⑩ to one end of short hose ⑤ using clamp ⑧.

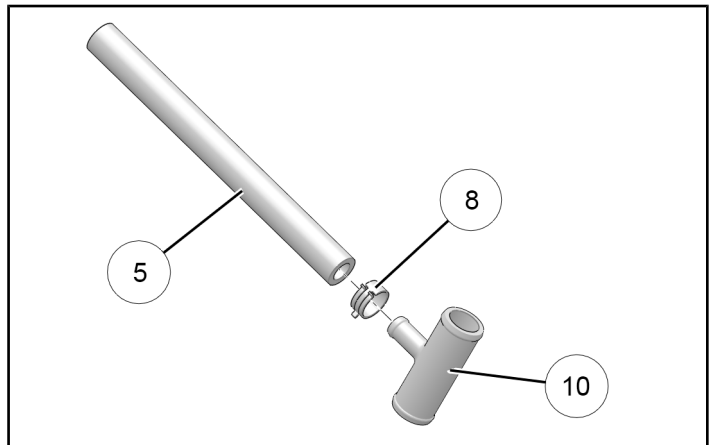

- b. Slip second clamp ⑧ over opposite end of hose ⑤, then install hose to 1/2 inch outlet hose fitting ⑧. Do not clamp hose to fitting at this time to allow hose assembly to rotate into proper position.

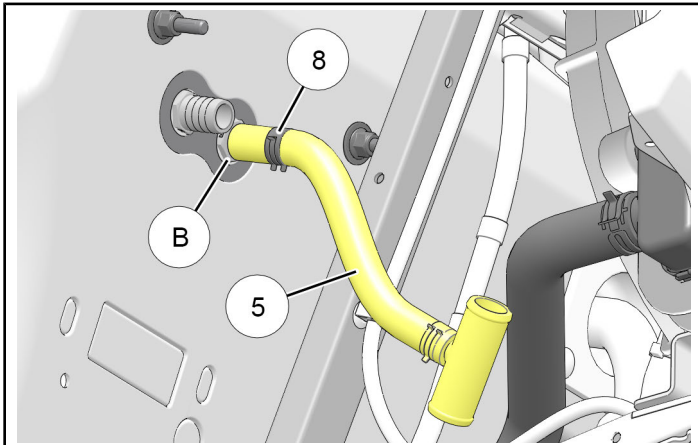

- c. Hold tee fitting ⑩ against existing cold return hose, rotating new hose ⑤ on fitting ⑧ as required to relieve twist.

Mark two cut lines on cold hose, approximately 1 inch (25 mm) apart, as shown.

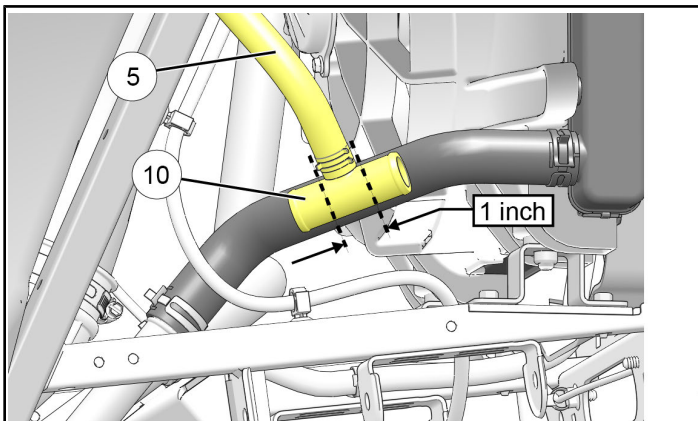

- d. Using two pinch-off pliers, clamp existing cold return hose approximately 3 inches from each mark to prevent excessive coolant loss.
- e. Place drain pan beneath work area, then cut existing cold hose at two marks. Discard 1 inch hose segment between marks.
- f. Install tee fitting ⑩ between cut ends of cold hose using two clamps ⑨. Ensure clamp orientation will not chafe against vehicle components.
- g. Move clamp ⑧ into final position on fitting ⑧.
- h. Temporarily install 3rd hose pinch-off pliers on hose ⑤ between hose fitting ⑧ and tee fitting ⑩ to prevent core from filling with coolant.
- i. Remove two pinch-off pliers from each side of tee fitting ⑩.

3. Install HOT SUPPLY heater hose between heater core inlet and 3-way valve.

- a. Hose ⑥, routed between 3-way valve outlet and heater core inlet, is formed to fit vehicle.

Hose orientation is as follows:

- **3-way valve outlet:** Hose end WITH “ENG” (towards engine) marking
 - **Heater core inlet:** Hose end WITHOUT marking
- b. Route end of hose ⑥ WITHOUT marking forward through center console opening, then up to heater core inlet. Ensure the following:
- White tape ① is located in approximate position shown (final adjustment will be made later)
 - Hose cannot chafe against vehicle components or contact moving parts, taking into consideration suspension travel and steering operation
 - Hose is not kinked at any point along its length

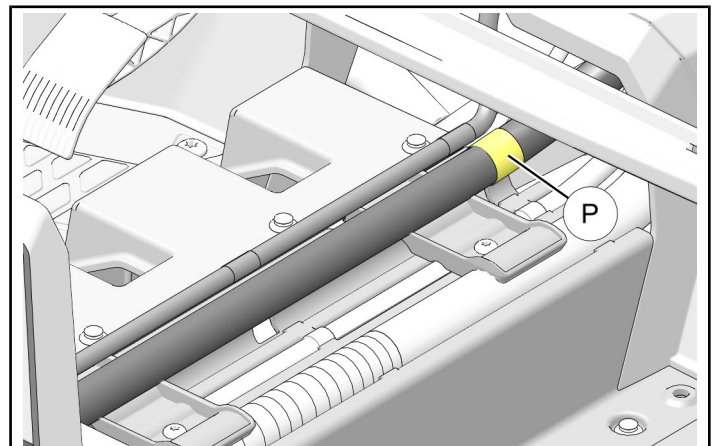

- c. Install end of hose ⑥ to 3/4 inch inlet hose fitting ③ using clamp ⑦ positioned in center of “H” marking. Ensure clamp orientation will not chafe against vehicle components.

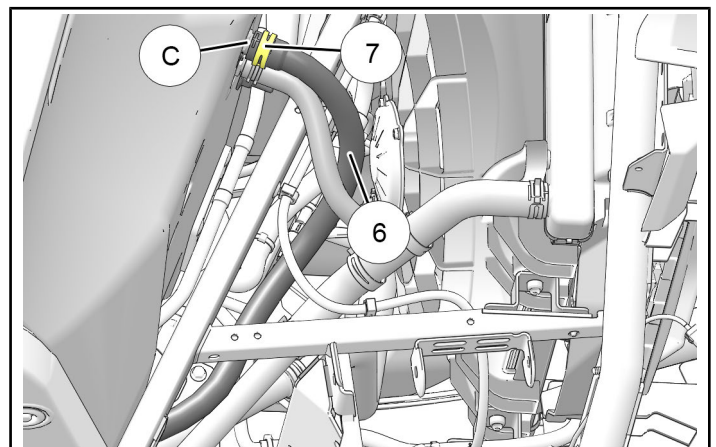

- d. Temporarily remove four screws **D** from clamps. Insert hose **6** into empty channel with white tape **P** located as shown, then loosely reinstall clamps and screws.

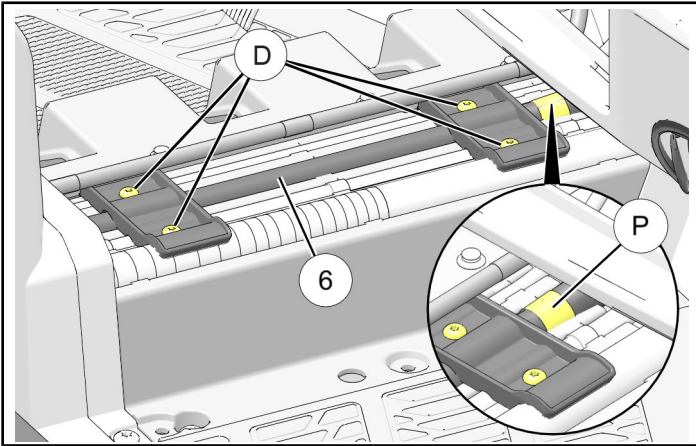

- e. Route hose **6** rearward to 3-way valve **A**, then join to **BOTTOM** fitting of valve using clamp **7** positioned in center of "H" marking.

Ensure the following:

- Hose and clamp cannot chafe against vehicle components or contact moving parts
- Hose is not kinked at any point along its length

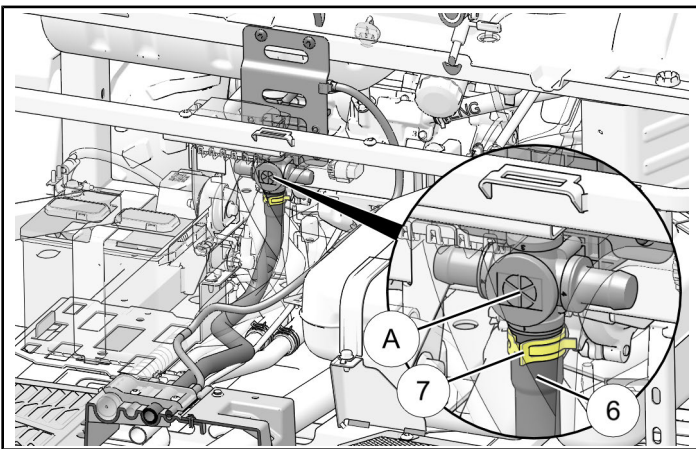

- f. Install double-cable tie **27** between hose **6** and rigid cold line **E**.

NOTE

Fastener hole in center of double-cable tie is not used.
Front suspension and driveline components hidden for clarity.

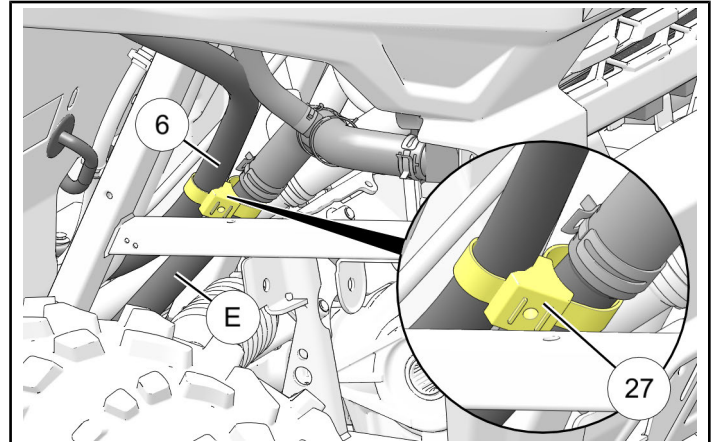

- g. Tighten four screws **D** for center console clamps. See previous Step d.

4. Install heater hoses between 3-way valve and engine.

- a. Use two hose pinch-off pliers to clamp existing hot **F** and cold **G** coolant hoses.

NOTE

Specific location not critical; choose location as close to engine as possible to minimize coolant loss.

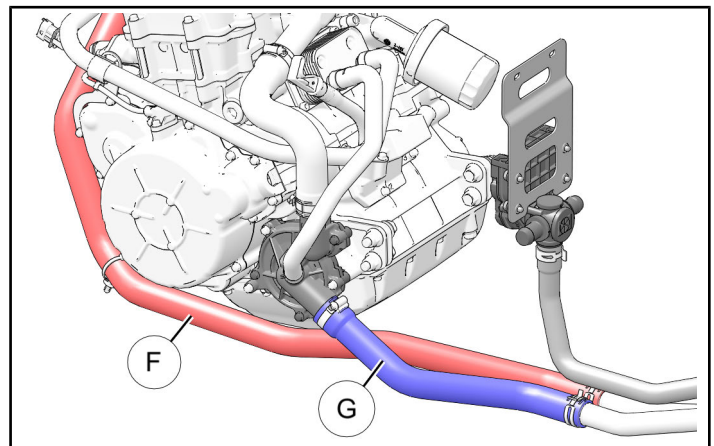

- b. Place drain pan beneath forward RH corner of engine (approximate locations of water pump and oil cooler).

- c. Locate existing hose **H** between oil cooler outlet **J** and water pump inlet **K**.

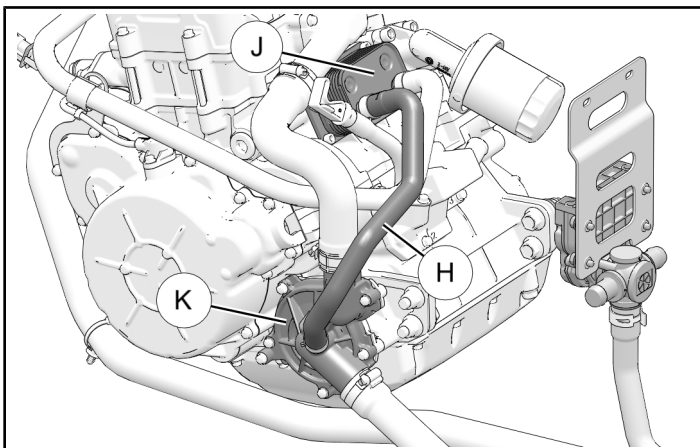

- d. Slide clamp **7** over hose **22** to a location near its flared (larger) end for later installation.

Orient hose so flared end is at **LEFT (DRIVER) SIDE** of 3-way valve **23**, and opposite end is at oil cooler outlet **J**. Install hose to valve fitting.

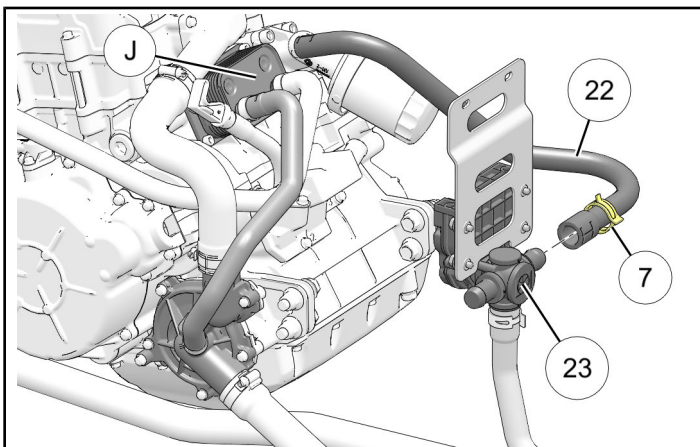

- e. Slide clamp **7** over hose **24** to a location near its flared (larger) end for later installation.

Orient hose so flared end is at **RIGHT (PASSENGER) SIDE** of 3-way valve **23**, and opposite end is at water pump inlet **K**. Install hose to valve fitting.

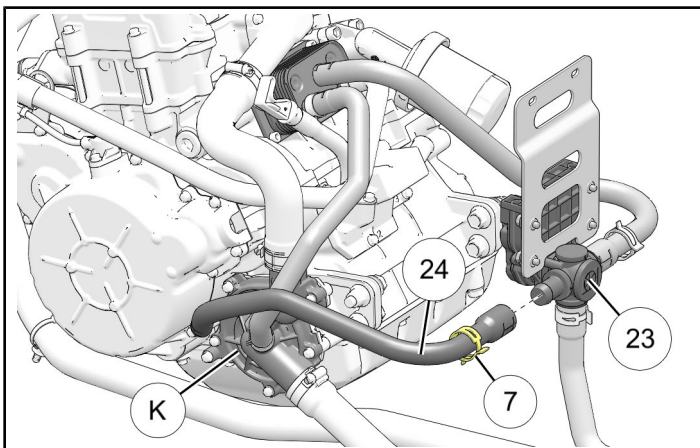

- f. Slide clamp **8** over opposite end of each hose **22** and **24** to a location far enough from ends to prevent interference during installation.

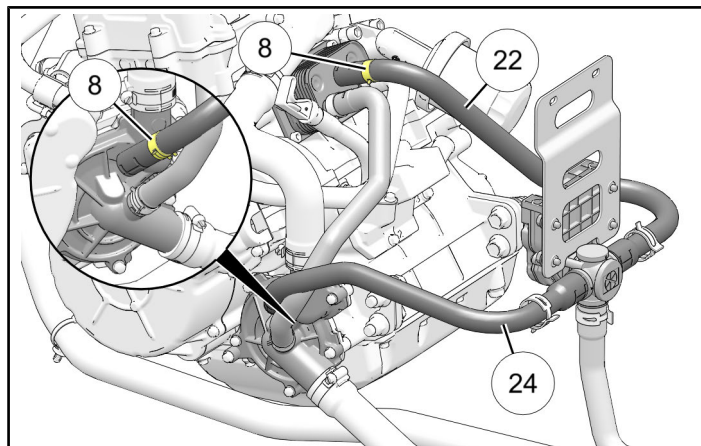

- g. Slide two clamps **L**, one on each end of existing hose **H**, to a location far enough from ends to prevent interference during removal.

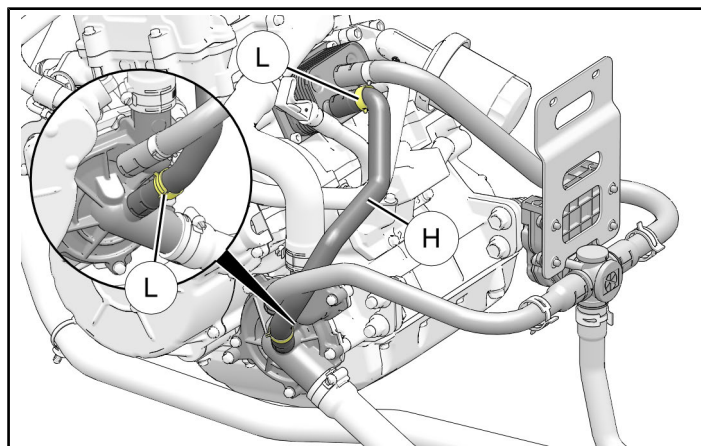

IMPORTANT

In the following steps coolant will flow from oil cooler outlet and water pump inlet fittings when existing hose **H** is removed.

To minimize coolant loss ensure the new hoses and clamps are ready for installation, and perform the next two steps in quick succession.

Clamps do not need to be moved into final position until after both new hoses are installed.

- h. Remove upper end of hose **H** from oil cooler outlet fitting **J**, then immediately install hose **22** to fitting.

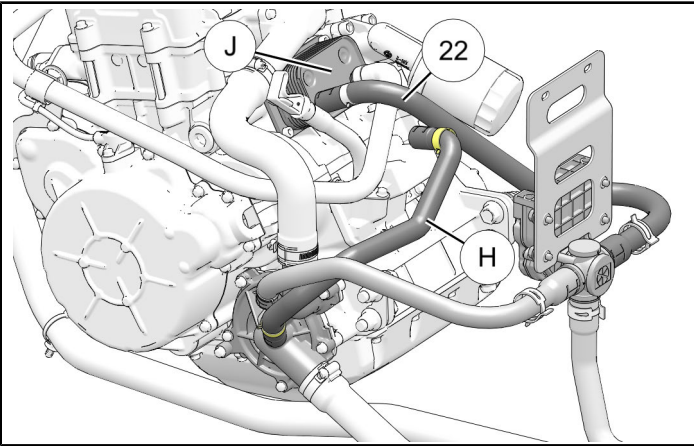

- i. Remove lower end of hose **H** from water pump inlet fitting **K**, then immediately install hose **24** to fitting.

Hose **H**, with associated clamps, will not be reused.

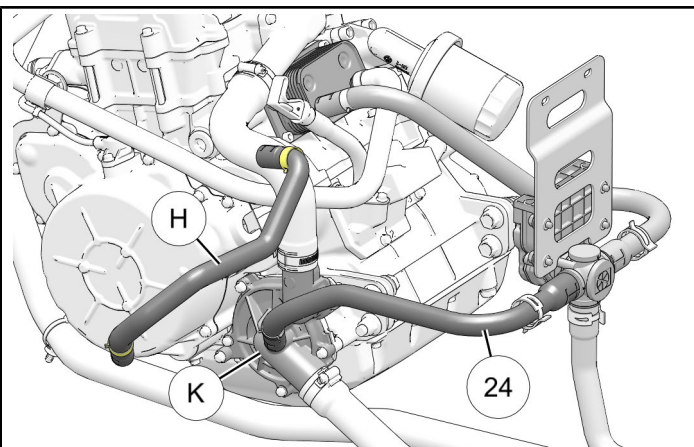

- j. Ensure routing of both hoses **22** and **24** prevents the following:
- Hoses cannot chafe against vehicle components or contact moving parts
 - Hoses cannot make contact with hot engine or exhaust components
 - Hoses are not kinked at any point along their length

- Water pump hose **24** is located at least 1/2 inch (13 mm) away from engine mount box beam as shown. If not, rotate hose on water pump fitting and/or 3-way valve fitting as required to achieve specified clearance.

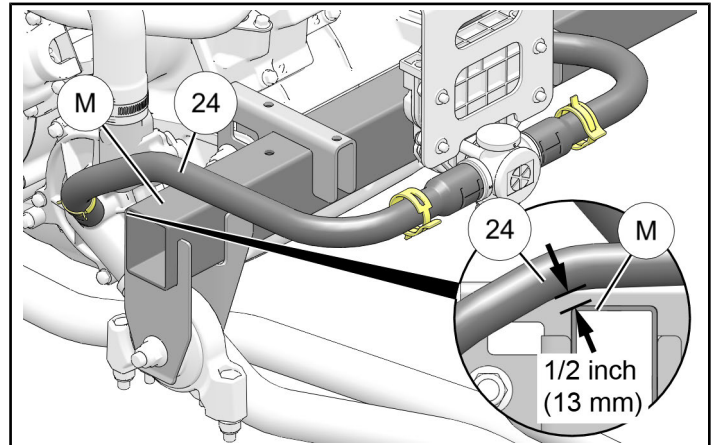

- k. Move two hose clamps **7** and two hose clamps **8** into final position in center of "H" markings **N** as shown. Ensure clamp orientation will not chafe against vehicle components.

NOTE

"H" markings shown at 3-way valve are typical of all locations.

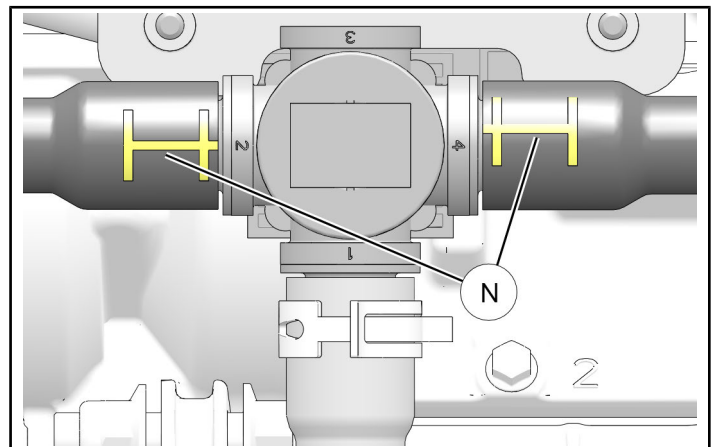
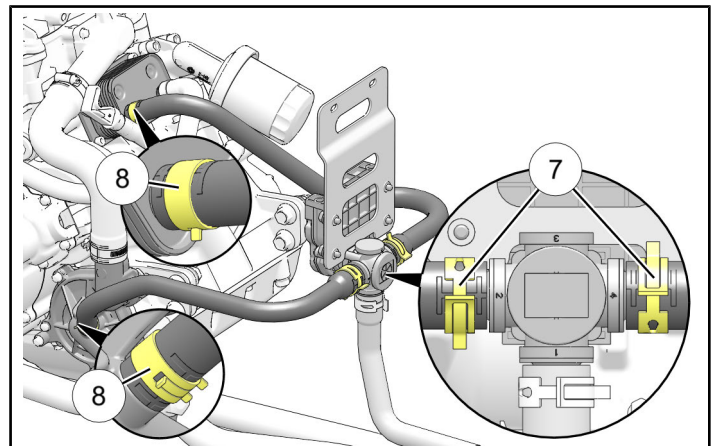

5. Remove hose pinch-off pliers from the following locations:
 - Hot ⑤ and cold ⑥ coolant hoses. See Step 4a.
 - From hose ⑤ between hose fitting ⑧ and tee fitting ⑩. See Step 2h.

IMPORTANT

ALL pinch-off pliers should be removed at this time.

6. Secure all four coolant hoses using cable ties ⑳ to prevent contact with hot components, sharp edges, or moving parts.
7. Properly dispose of any drained coolant per local and/or state regulations.

BLEED COOLING SYSTEM

Two bleed procedures are provided: one with the front end of the vehicle **LIFTED**, and another with the vehicle **LEVEL**. Where bleed steps differ, both procedures are called out.

TIP

Performing the **LIFTED** procedure is faster, easier, and generally results in a more complete system bleed.

NOTE

It is suggested two people perform the **LEVEL** procedure: one to fill radiator, and one to monitor bleed screw.

⚠ WARNING

Always wear safety goggles and proper shop clothing when performing this procedure. Failure to do so may result in severe injury or death.

⚠ WARNING

Follow all chemical manufacturer instructions and safety precautions. Failure to follow all manufacturer instructions and precautions may result in severe injury or death.

1. Reconnect black negative (-) cable to battery, then reinstall under-seat storage compartment(s).
2. If performing **LEVEL** procedure, proceed to Step 3.

If performing **LIFTED** procedure, properly lift and safely support front of vehicle 12–18 inches above rear of vehicle.

⚠ WARNING

DO NOT USE JACK TO STABILIZE OR SUPPORT VEHICLE. Chocks must be used to stabilize vehicle prior to lifting. **Blocks or jack stands** must be used to support vehicle after lifting.

Failure to properly chock and block vehicle may allow vehicle to fall, resulting in severe injury or death.

NEVER place any part of your body under lifted vehicle without properly chocking and blocking vehicle.

Observe the following:

- a. Vehicle must be on **FIRM, LEVEL, and DRY SURFACE** to permit safe jacking.
 - b. Ensure vehicle transmission is in “**PARK**” and ignition switch is in “**OFF**” position.
 - c. Securely chock **FRONT AND REAR** sides of **BOTH** rear tires to prevent vehicle from moving.
 - d. **SUPPORT VEHICLE WITH BLOCKS OR JACK STANDS** designed for that purpose and which have adequate weight capacity.
 - e. **FOLLOW ALL INSTRUCTIONS** included with jack, blocks, jack stands, and any other equipment used.
3. Allow engine to cool to room temperature.
 4. Place drain pan in position:
 - **LEVEL** procedure: Beneath engine
 - **LIFTED** procedure: Beneath radiator

⚠ WARNING

Do NOT remove radiator pressure cap when system is hot. Hot cooling system will be pressurized, and opening system will result in uncontrolled release of hot coolant, resulting in severe burns or other injuries.

5. Remove recovery bottle cap (A) and radiator pressure cap (B). Fill recovery bottle to MAX COLD line and radiator to filler neck with **Polaris Antifreeze 50/50 Pre-Mix**. Leave both caps off at this time.

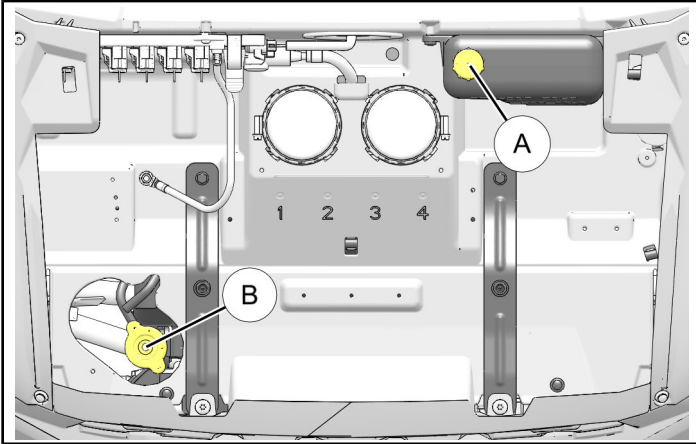

6. Open heater core valve.
 - a. Turn ignition key to "ON" position. Do NOT start engine.
 - b. Turn heater temperature control to full HOT. Wait 10 seconds.
 - c. Turn ignition switch to "OFF" position and remove key.

NOTE

Heater fan speed position is irrelevant.

7. Bleed engine block.
 - a. Raise vehicle bed.

- b. Use 5/16 inch socket to loosen bleed screw (C) at front of engine until escaping air can be heard (approximately 2 full turns). Do NOT remove bleed screw.

NOTE

Exhaust system shown partially transparent for clarity.

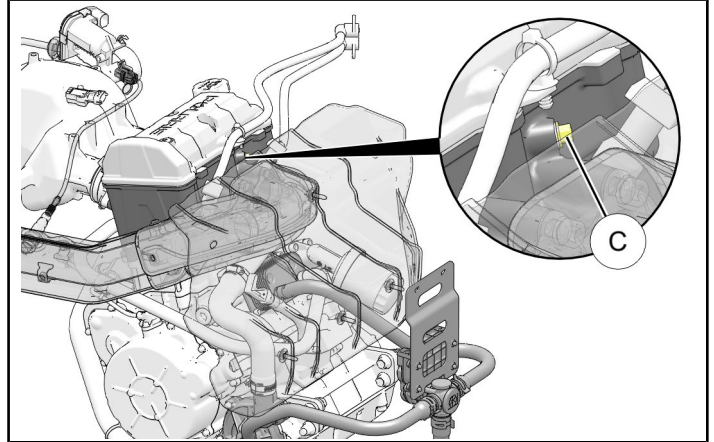

- c. Add **Polaris Antifreeze 50/50 Pre-Mix** to radiator as coolant fills heater system. Stop filling when a steady stream of coolant drains from bleed screw (C).
 - d. Close bleed screw (C) and torque to specification.

TORQUE

7 ft. lbs. (10 Nm) ± 10%

- e. Fill recovery bottle to MAX COLD line and reinstall cap (A).
 - f. **LEVEL** procedure: Fill radiator to filler neck and reinstall pressure cap (B).
 8. Start engine, leaving heater temperature control at full hot and turning heater fan to high speed.

⚠ WARNING

LEVEL procedure: Do NOT remove radiator pressure cap when system is hot. Hot cooling system will be pressurized, and opening system will result in uncontrolled release of hot coolant, resulting in severe burns or other injuries.

IMPORTANT

LIFTED procedure: Radiator pressure cap remains OFF throughout entire bleed procedure.

9. Allow engine to idle until radiator fan has cycled 2 times, **OR** until 215° F (102° C) temperature limit is reached.

While engine is warming up perform the following steps:

- a. Monitor engine/coolant temperature at all times. If temperature exceeds 215° F (102° C), then **IMMEDIATELY** shut off engine, allow engine to cool to room temperature, and re-bleed system.
- b. Monitor coolant level as follows:
 - **LEVEL** procedure: Monitor coolant level in recovery bottle. Add coolant as required.

NOTE

If leaks are present cooling system may not draw coolant from recovery tank.

- **LIFTED** procedure: Monitor coolant level in radiator (cap remains OFF). Add coolant as required.

NOTE

Coolant may periodically “burp” out of radiator filler neck as air exits system.

- c. Inspect system for leaks. Repair leaks as required, allowing engine to cool to room temperature before opening system.
10. Test heater operation. If inadequate heat is present allow engine to cool to room temperature, then re-bleed system using other bleed procedure (**LIFTED** or **LEVEL**, as applicable).
11. Allow engine to cool to room temperature.

⚠ WARNING

Do **NOT** remove radiator pressure cap when system is hot. Hot cooling system will be pressurized, and opening system will result in uncontrolled release of hot coolant, resulting in severe burns or other injuries.

12. Remove recovery bottle cap (A) and radiator pressure cap (B) (if installed), then fill recovery bottle to MAX COLD line and radiator to filler neck. Reinstall caps.

IMPORTANT

Periodically check coolant level during first few hours of operation.

13. Lower vehicle bed.
14. **LIFTED** procedure: Remove support equipment and lower vehicle. Follow all manufacturers instructions for equipment use.
15. Properly dispose of any drained coolant per local and/or state regulations.

RESTORE VEHICLE TO OPERATIONAL CONDITION

1. Reinstall upper dash cupholder. See previous section **PREPARE VEHICLE FOR INSTALLATION**, Step 5.
2. Reinstall center floor console. See previous section **PREPARE VEHICLE FOR INSTALLATION**, Step 11.
3. Install lower storage compartment cover (29) by inserting two lower tabs into dash panel, then secure using two retained push pin rivets (A).

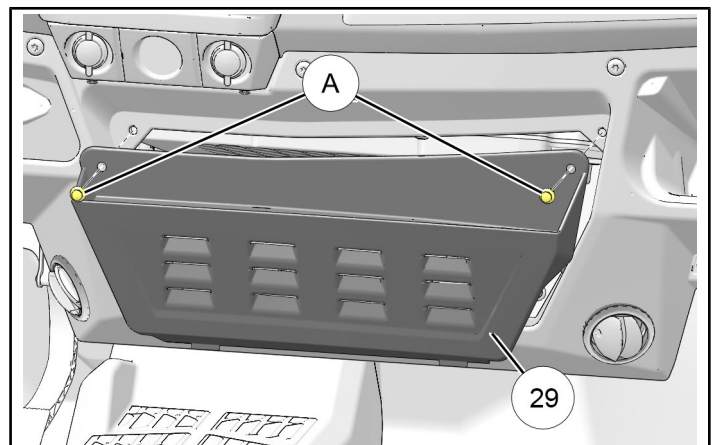

4. Reinstall or close windshield (if applicable).
5. Reinstall hood.

FEEDBACK FORM

A feedback form has been created for the installer to provide any comments, questions or concerns about the installation instructions. The form is viewable on mobile devices by scanning the QR code or by clicking [HERE](#) if viewing on a PC.

