

# DASH AMP KIT



**P/N 2884064**

## APPLICATION

Verify accessory fitment at [Polaris.com](http://Polaris.com).

## BEFORE YOU BEGIN

Read these instructions and check to be sure all parts and tools are accounted for. Please retain these installation instructions for future reference and parts ordering information.

## KIT CONTENTS

This kit contains parts for installation of the dash amp only. Prior installation of the following additional components is also required (sold separately):

- RIDE COMMAND™ 7" Display Mount Kit, PN 2884021 (or equivalent factory installation)
- Speaker Kit

This Kit includes:

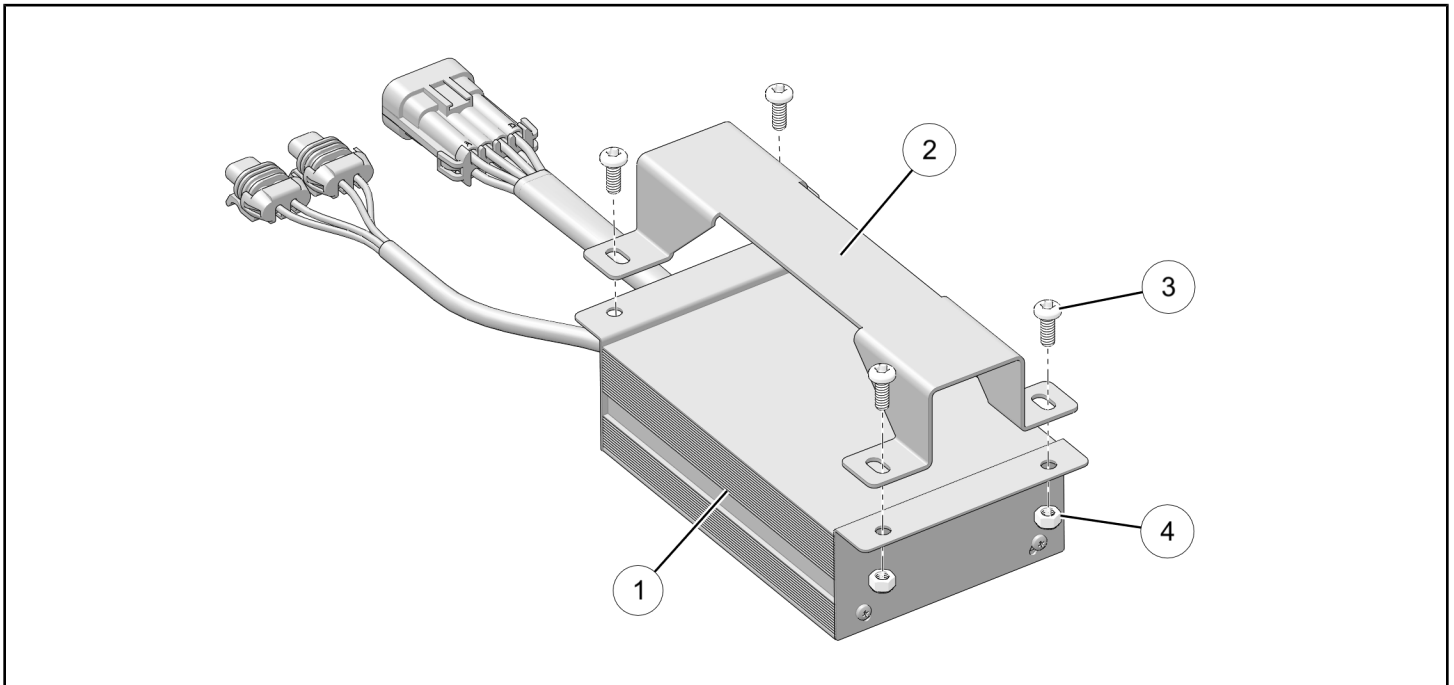

REF	QTY	PART DESCRIPTION	PART NUMBER
1	1	Amp	-
2	1	Bracket	5267462-458
3*	4	Screw, Torx® Pan Head, High/Low - M5 X 12	-
4*	4	Nut, Hex, Locking - M5	-
	1	Instructions	9929382

Items marked (\*) are included in Hardware Kit PN 2207961.

## TOOLS REQUIRED

- Safety Glasses
- Pliers, Push Pin Rivet
- Screwdriver Set, Torx®
- Wrench Set, Metric

## IMPORTANT

Your Dash Amp Kit is exclusively designed for your vehicle. Please read the installation instructions thoroughly before beginning. Installation is easier if the vehicle is clean and free of debris. For your safety, and to ensure a satisfactory installation, perform all installation steps correctly in the sequence shown.

## HARNESS DETAIL

### AMP ①:

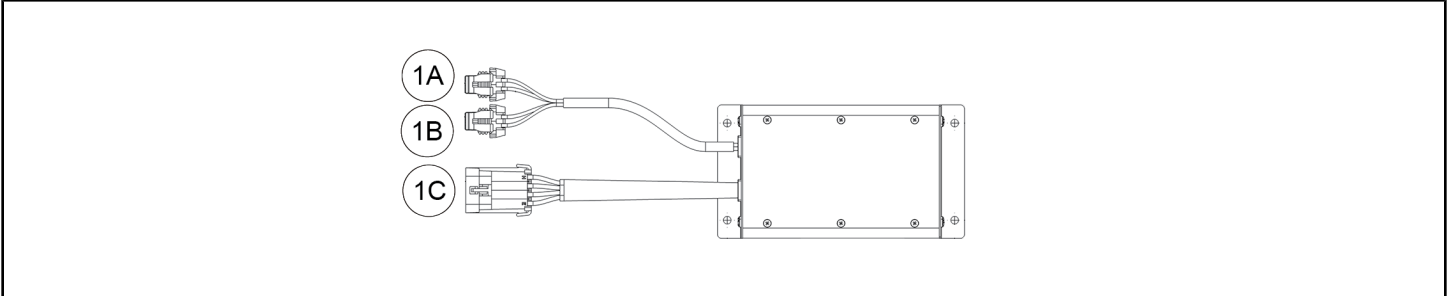

REF	PART DESCRIPTION	WIRE COLOR	PIN QTY/ GENDER	CONNECTS TO
1A	Connector, Speaker Signal OUT, RH	Gray*	2 female	Speakers (sold separately)
1B	Connector, Speaker Signal OUT, LH	White*	2 female	
1C	Connector, Audio Source	-	8 male	RIDE COMMAND™ display harness (included in kit PN 2884021 or equivalent), connector identified as <b>AUDIO AMP 1</b>

\* With or without black stripe.

## INSTALLATION INSTRUCTIONS

- Shift vehicle transmission into “PARK”. Turn ignition switch to “OFF” position and remove key.
- Gain access.
  - Remove hood.
  - Remove windshield (if installed).
  - Remove upper dash storage compartment by removing two push pin rivets (A), then slide compartment rearward to detach two tabs on lower rear corners. Retain rivets.

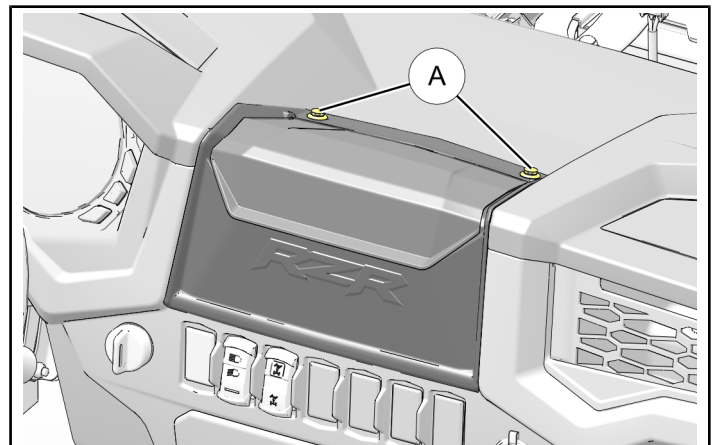

- d. Remove upper dash panel.
  - i. Remove four screws **B** securing upper dash panel. Retain screws.

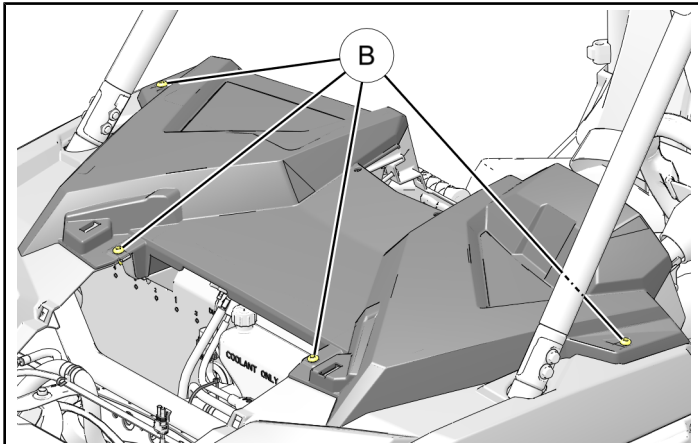

- ii. Lift front of upper dash panel, detaching two posts **C** (LH and RH). Carefully lift and pull panel rearward, disengaging two retaining clips **D** (LH and RH) and two tabs **E**.

**NOTE**

Tabs located immediately above instrument cluster.

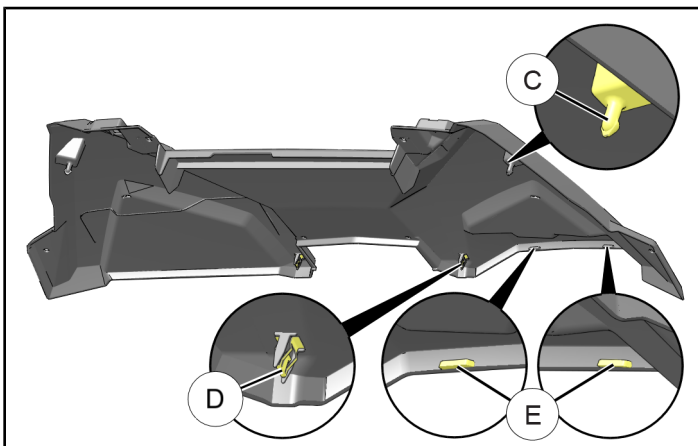

- e. Remove left front fender flare by removing four 25 mm screws **F**, one 50 mm screw **G**, one #14 X 1-3/4 screw **H**, and one push pin rivet **J**. Set fender flare and hardware aside.

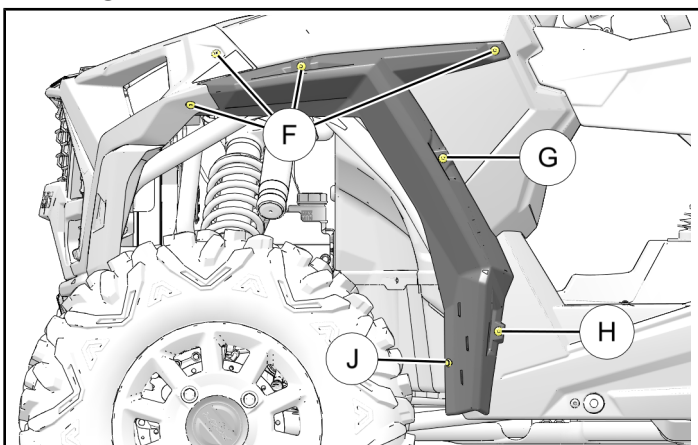

- f. Reposition left front fender.
  - i. Remove three additional 25 mm screws **F** and two 20 mm door striker screws **K**. Retain hardware.

**TIP**

Apply tape around perimeter of door striker to identify location and minimize door adjustment when striker is reinstalled.

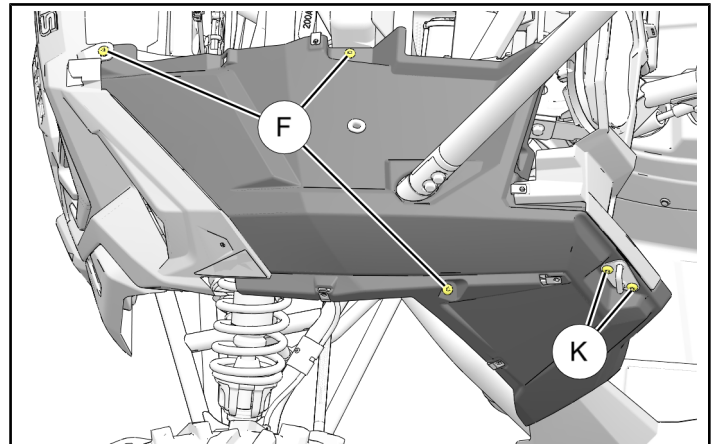

- ii. Carefully pull fender from beneath front fascia at location **L**. Also pull instrument panel slightly rearward, disengaging two retaining clips **M** from fender.

Do NOT lift fender up over ROPS fasteners at this time.

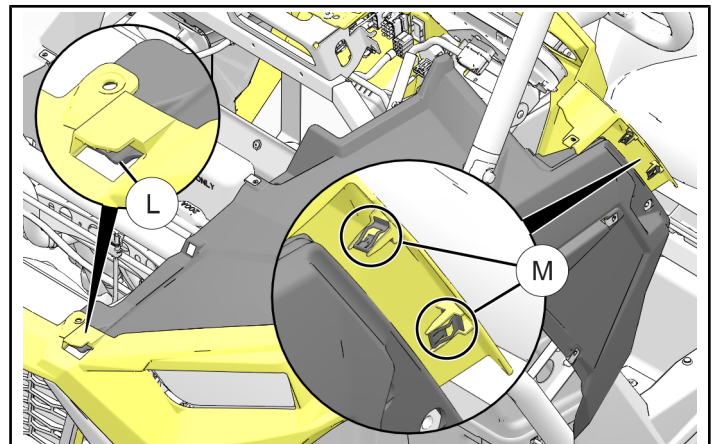

- iii. With fender loose, apply tape over ROPS fasteners **N** (screw heads and nuts) and around cutout **P** to minimize contact with fender in next step.

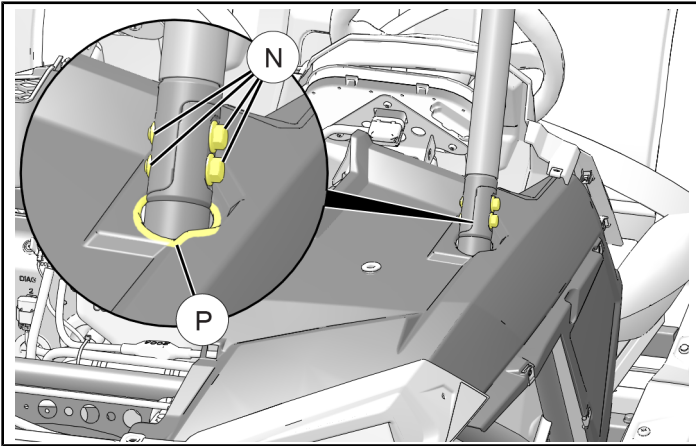

- iv. Carefully lift fender over ROPS fasteners and up A-pillar, rotating as required, to gain access to upper dash structure.

**NOTE**  
Final amp location **Q** shown for reference. Fender hidden for clarity.

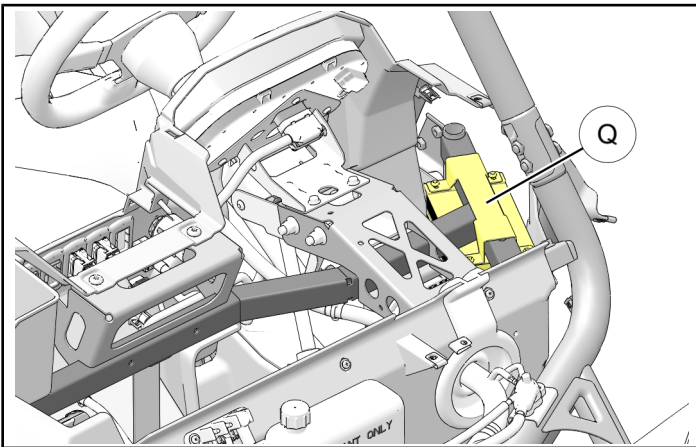

- 3. Position amp **1** against lower side of chassis tube, oriented so harnesses exit towards FRONT of vehicle. Position bracket **2** on upper side of chassis tube, then assemble bracket to amp using four each screws **3** and nuts **4**.

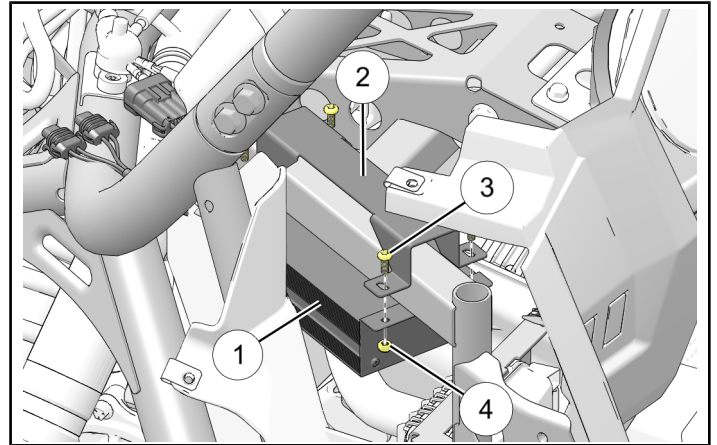

- 4. Connect amp to audio components.

**NOTE**  
See previous section, **HARNES DETAIL**, for connector identification.

- a. Join connectors 1A and 1B on amp **1** to speakers (sold separately).
- b. Join connector 1C on amp **1** to RIDE COMMAND™ display harness (included in kit PN 2884021 or equivalent), connector identified as **AUDIO AMP 1**.

**NOTE**  
**AUDIO AMP 1** is a **POWERED** connector (along with audio signal). **AUDIO AMP 2** and **AUDIO AMP 3** are **UNPOWERED** connectors (audio signal only).  
If amp does not power on when installation is complete, ensure connector 1C is joined to **AUDIO AMP 1**.

- 5. Secure audio harnesses as required to prevent contact with hot components, sharp edges, or moving parts.
- 6. Restore access in reverse order of disassembly.

**FEEDBACK FORM**

A feedback form has been created for the installer to provide any comments, questions or concerns about the installation instructions. The form is viewable on mobile devices by scanning the QR code or by clicking [HERE](#) if viewing on a PC.

