

DOME LIGHT KIT



P/N 2884047

APPLICATION

Verify accessory fitment at Polaris.com.

BEFORE YOU BEGIN

Read these instructions and check to be sure all parts and tools are accounted for. Please retain these installation instructions for future reference and parts ordering information.

KIT CONTENTS

This kit contains parts for installation of the dome light only. Prior installation of one of the following additional kits is also required (sold separately):

- Premium Poly Roof Kit, PN 2883800, 2883801, or equivalent
- Sport Roof Kit, PN 2883780, 2883781, or equivalent

This Kit includes:

NOTE

The same harness ② is shown below in both two and four seat configurations.

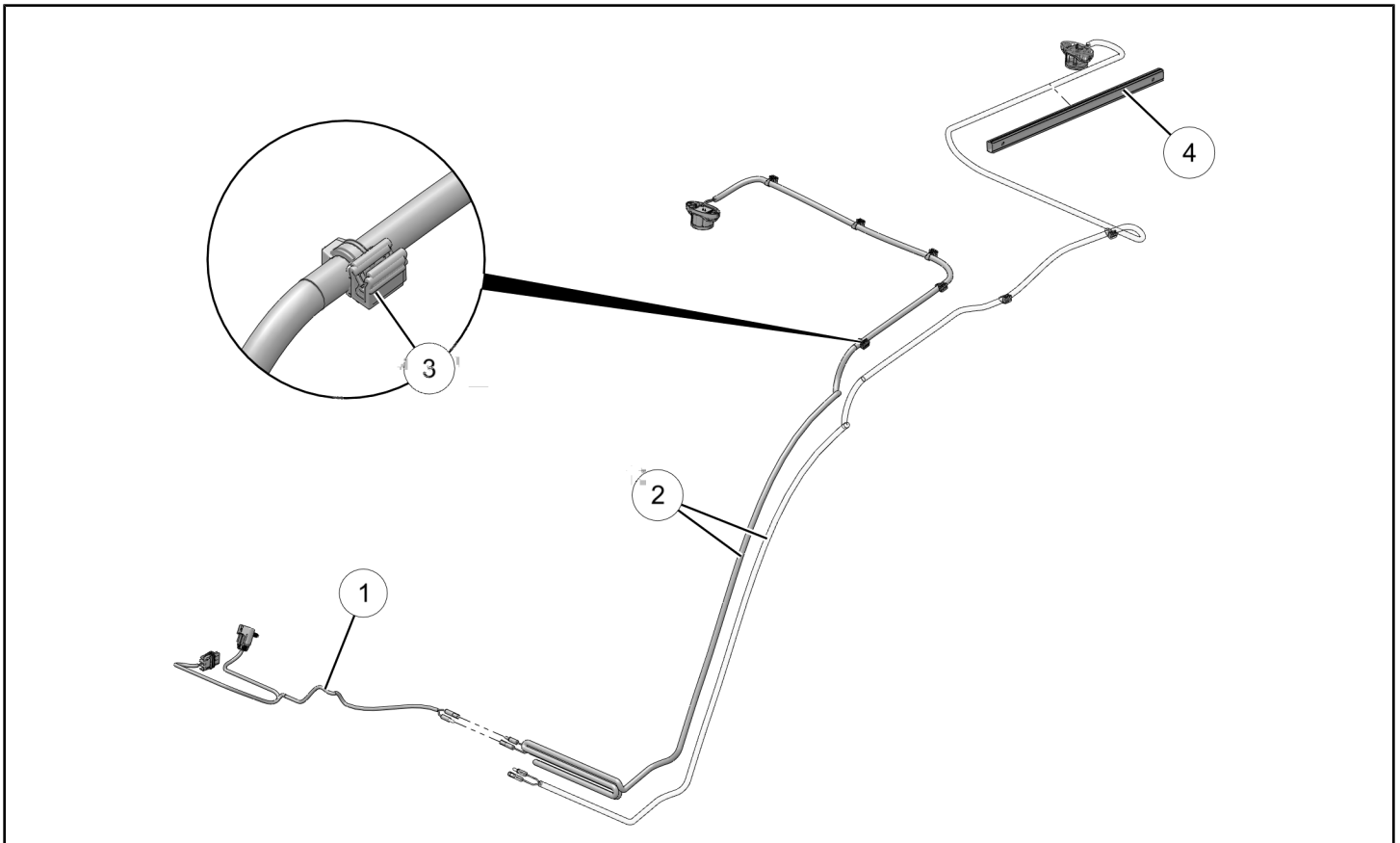

REF	QTY	PART DESCRIPTION	PART NUMBER
1	1	Harness, Dash	2414810
2	1	Harness, ROPS	2414795

REF	QTY	PART DESCRIPTION	PART NUMBER
3	5	Edge Clip	7082403
4	1	Conduit, Routing	5416632
5	2	Screw, Torx® Pan Head, High/Low - #10 X 5/8 (not shown)	7518238
6	7	Cable Tie (not shown)	7080492
	1	Instructions	9929358

TOOLS REQUIRED

- Safety Glasses
- Cutting Tool
- Drill
- Drill Bit: 1/4 inch (6 mm)
- Pliers, Push Pin Rivet
- Screwdriver Set, Torx®

IMPORTANT

Your Dome Light Kit is exclusively designed for your vehicle. Please read the installation instructions thoroughly before beginning. Installation is easier if the vehicle is clean and free of debris. For your safety, and to ensure a satisfactory installation, perform all installation steps correctly in the sequence shown.

HARNESS DETAIL

DASH HARNESS ①:

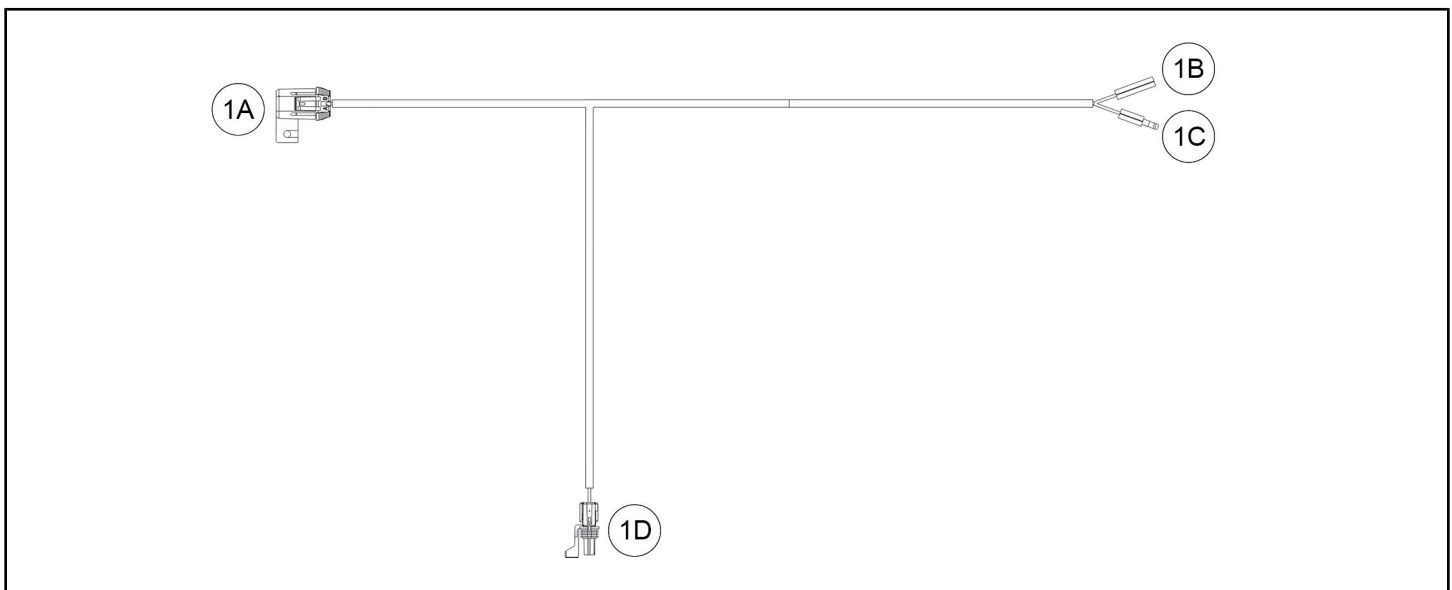

REF	PART DESCRIPTION	WIRE COLOR	PIN QTY/ GENDER	CONNECTS TO
1A	Fuse Block	-	-	Vehicle structure
1B	Connector, Bullet, Key Ignition / B+	Orange/ White	1 female	ROPS harness ②, connector 2C
1C	Connector, Bullet, Ground	Brown	1 male	ROPS harness ②, connector 2B
1D	Connector, Terminal Block	-	3 female	Pulse™ terminal block

ROPS HARNESS ②:

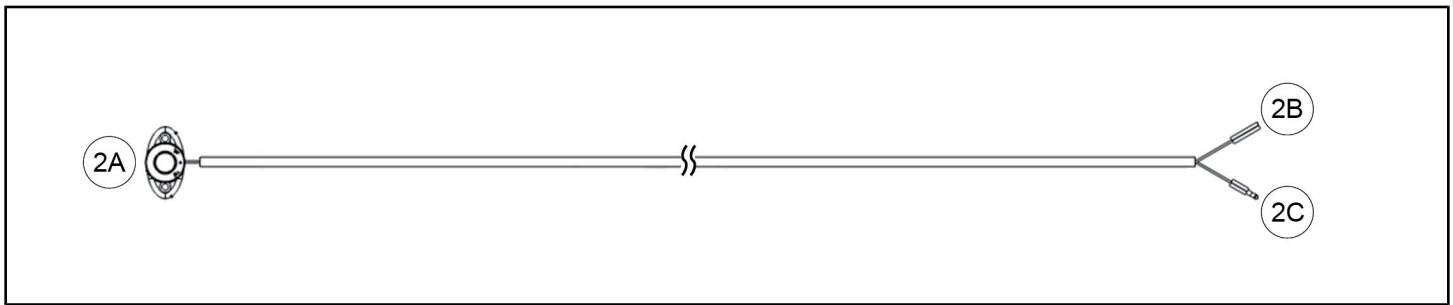

REF	PART DESCRIPTION	WIRE COLOR	PIN QTY/ GENDER	CONNECTS TO
2A	Light, Removable LED	-	-	Vehicle structure
2B	Connector, Bullet, Ground	Brown	1 female	Dash harness ①, connector 1C
2C	Connector, Bullet, Key Ignition / B+	Orange/ White	1 male	Dash harness ①, connector 1B

INSTALLATION INSTRUCTIONS

1. Shift vehicle transmission into “PARK”. Turn ignition switch to “OFF” position and remove key.

⚠ WARNING

Ensure red positive (+) battery terminal is COMPLETELY COVERED by protective boot. Accidental tool contact across both battery terminals will result in high current electrical arc, and may result in battery explosion. Death or serious personal injury may occur.

2. Remove driver’s seat (**GENERAL® 4**: left rear passenger seat) and battery access cover, then disconnect black negative (-) cable from battery.
3. Gain access.
 - a. Remove hood.
 - b. If windshield is installed, then open it or remove it as required to gain access to upper dash panel.

- c. Remove upper dash panel.
 - i. Remove five push pin rivets ① from forward side of upper dash panel. Retain rivets.

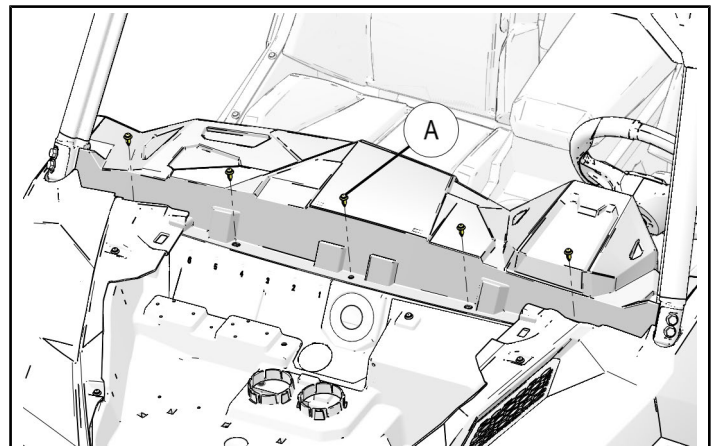

- ii. Slide upper dash panel to rear, disengaging eight spring clips ②.

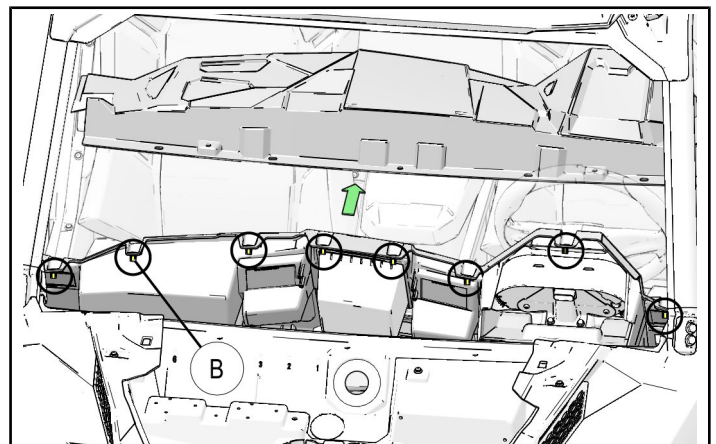

- d. If a roof liner is NOT installed on your vehicle, then proceed to Step 5. Otherwise, remove liner(s) as follows:

GENERAL® 4 Vehicles - Rear Liner

- i. Remove two screws (C) on forward side of B-pillar cross-member. Retain hardware.

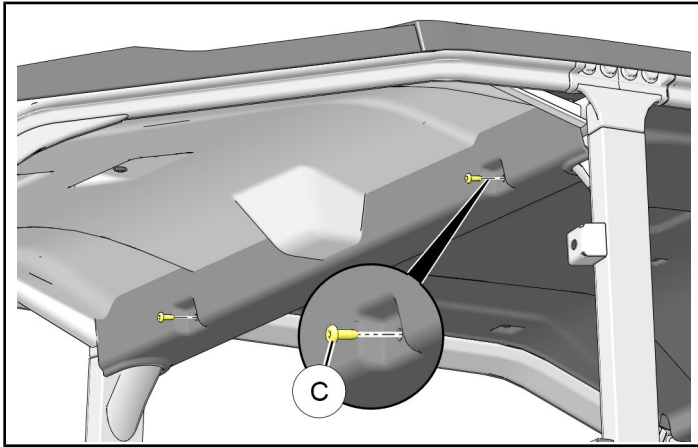

- ii. Remove six screws (D), two on rear side of B-pillar cross-member, and four near center of liner. Retain hardware.

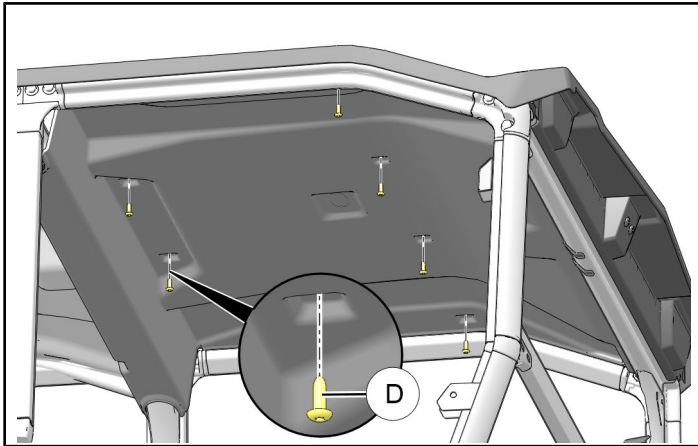

- iii. Carefully pull LH and RH edges of liner (E) down from between ROPS and roof seal, then remove rear edge of liner from above C-pillar cross-member. Set liner aside.

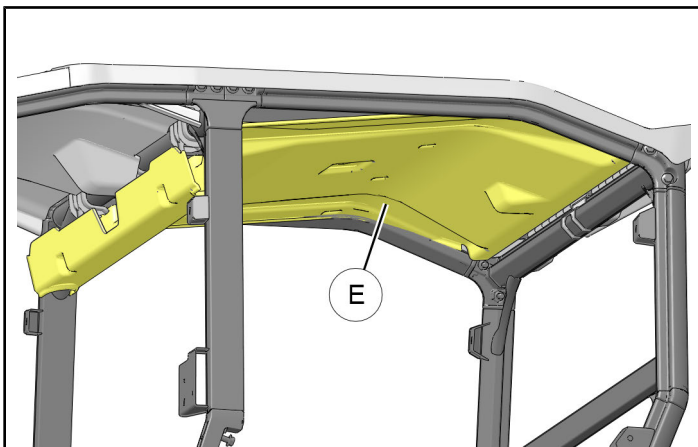

All GENERAL® Vehicles - Front Liner

NOTE

2-seat liner shown; 4-seat front liner similar.

- i. Remove two each screws (F) and washers (G), and two outboard screws (H) (one on each side of liner). Retain hardware.

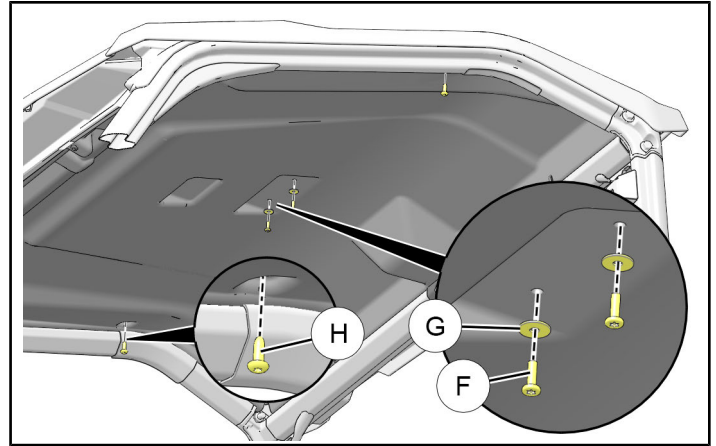

- ii. If overhead sound bar is installed, proceed to next step iii. Otherwise remove six screws (I). Retain hardware.

NOTE

LH side shown; RH side opposite.

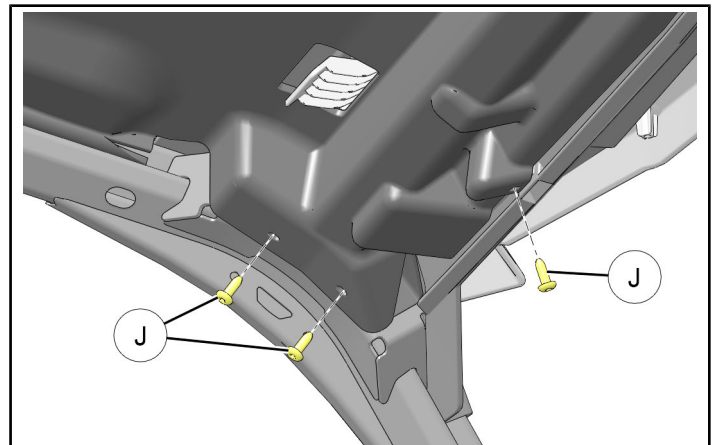

iii. Access underside of roof.

NOTE

2-seat liner shown; 4-seat front liner similar.

- **WITH Overhead Sound Bar:** Starting at rear of vehicle, carefully pull LH and RH edges of liner from between ROPS and roof seal, then tip rear edge of liner down just enough to access underside of roof.

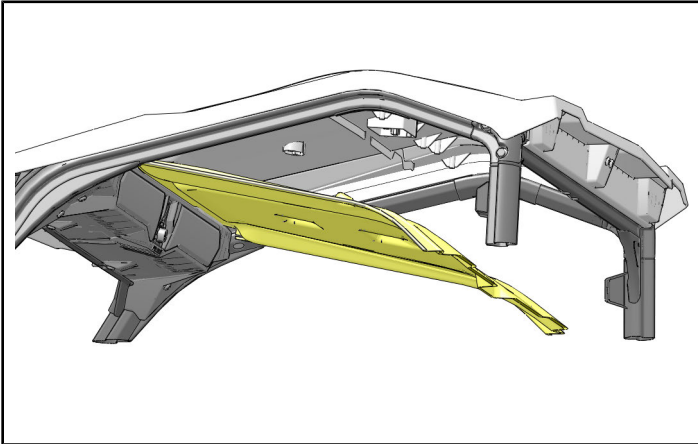

- **WITHOUT Overhead Sound Bar:** Starting at front of vehicle, carefully pull LH and RH edges of liner from between ROPS and roof seal, then remove liner.

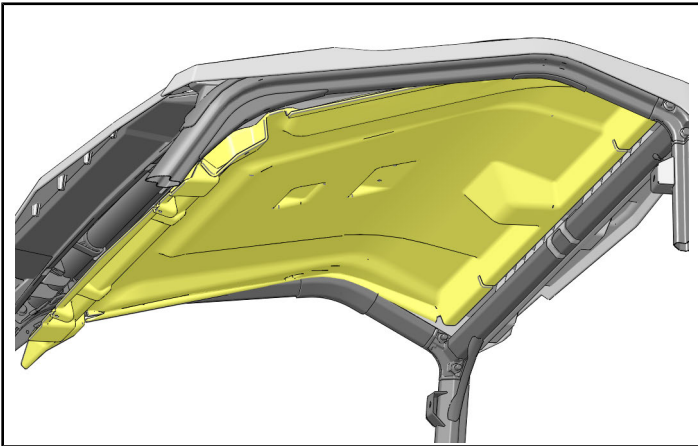

4. Cut dome light opening (K) in applicable liner along **INSIDE EDGE** of recessed marking.

GENERAL® - Front Liner

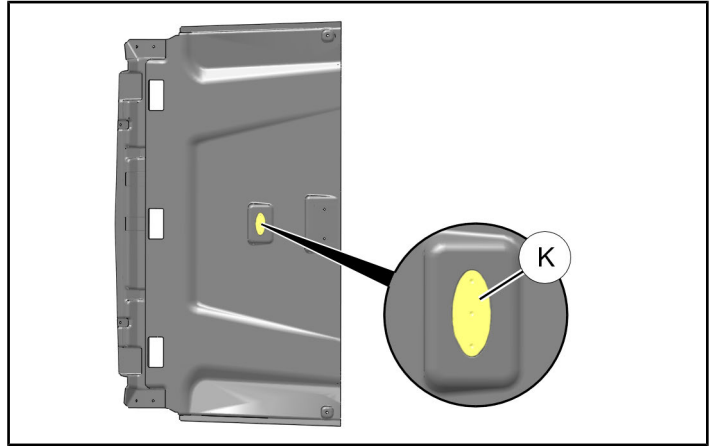

GENERAL® 4 - Front and Rear Liners

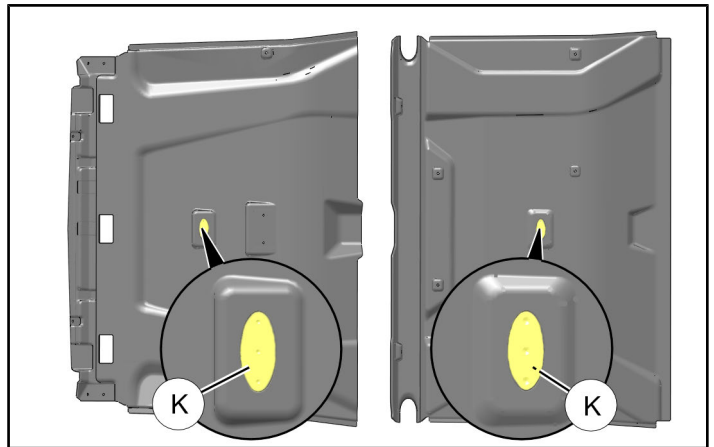

5. Install dash harness ①.

NOTE

See previous section, **HARNESSES DETAIL**, for connector identification.

- a. Route bullet connectors 1B and 1C on dash harness ① from under-hood compartment rearward through firewall grommet ① into upper dash compartment.

NOTE

Fuse block 1A and terminal block connector 1D remain on forward side of firewall grommet.

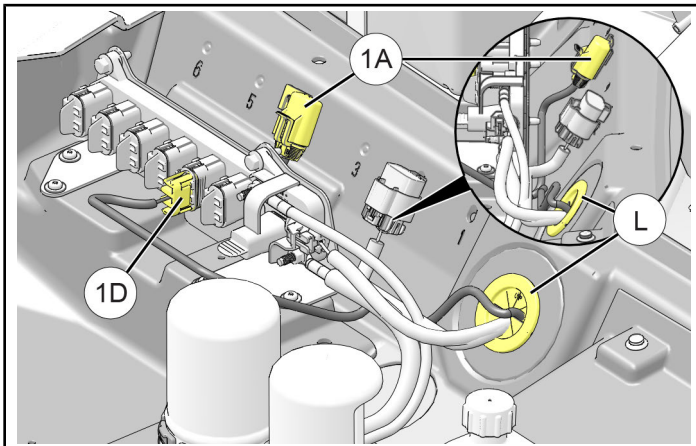

- b. Drill out one accessory plug (1/4 inch / 6 mm) on forward side of firewall, then install fuse block 1A.

IMPORTANT

Control drill depth to prevent damage to underlying structure, components, wiring, lines/hoses/ducts, etc.

NOTE

Use fir tree clip attached to fuse block. Tab with hole is not used in this application.

- c. Open power cap on vehicle terminal block at any open location, then plug in connector 1D.

- d. Route bullet connectors 1B and 1C from firewall grommet ① towards LH side of dash along main chassis harness. Do not secure dash harness to main chassis harness at this time.

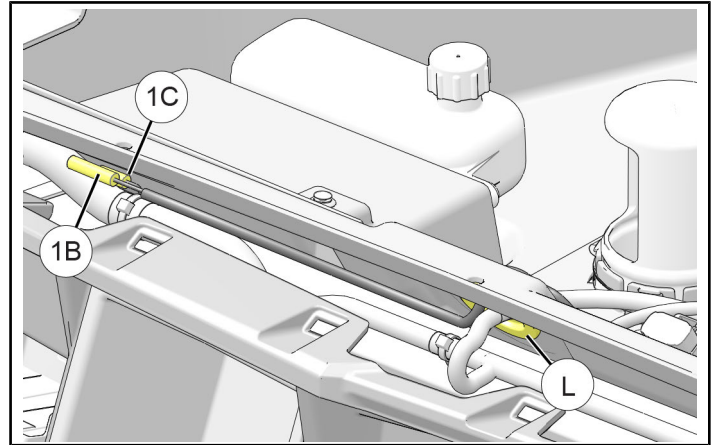

6. Install ROPS harness ②.

- a. Route two bullet connectors 2B and 2C on ROPS harness ② into hole ① at top of driver side A-pillar, down ROPS, out of welded coupler at base of pillar, and into upper dash compartment.

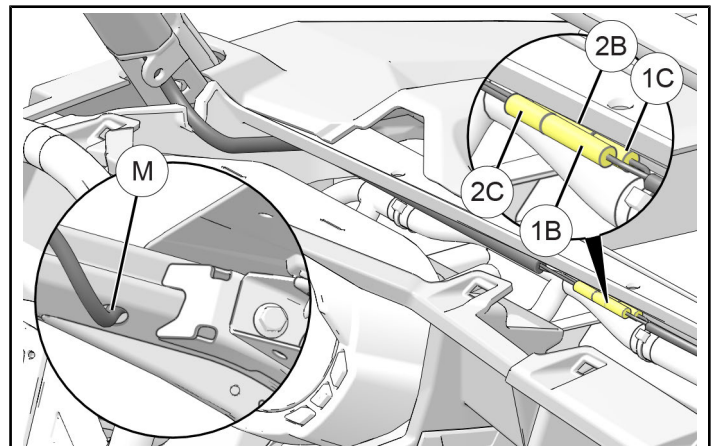

- b. Join bullet connectors 2B and 2C to mating bullet connectors 1C and 1B on dash harness ①, matching wire colors (orange/white to orange/white, brown to brown).

c. Secure harness to roof.

All GENERAL® Vehicles - Front Installation

i. Hold dome light 2A in mounting location (or temporarily secure with two screws ⑤).

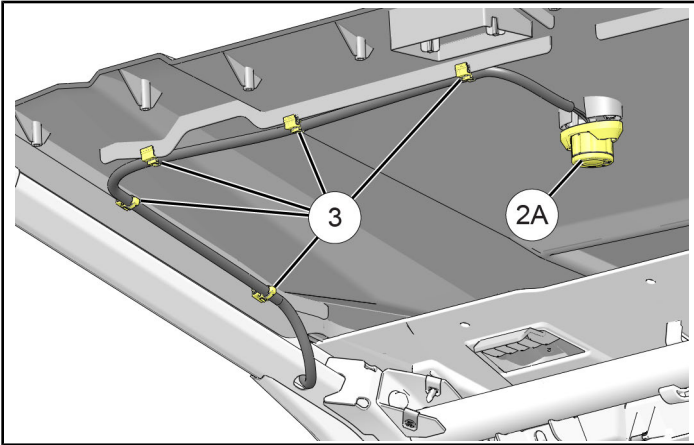

ii. Provide adequate harness slack to allow light base to easily pass through cutout in roof liner (if applicable; see previous Step 4), then secure harness to roof using five edge clips ③.

Ensure harness is routed and secured to prevent contact with hot components, sharp edges, or moving parts.

GENERAL® 4 Vehicles - Rear Installation

i. Hold dome light 2A in mounting location (or temporarily secure with two screws ⑤).

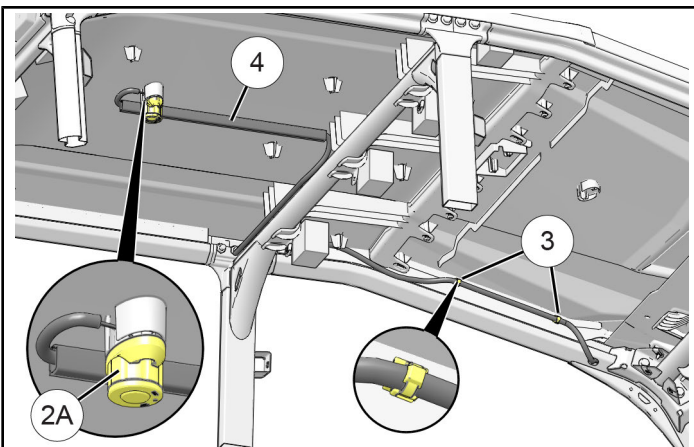

ii. Determine mounting location for routing conduit ④, trimming length as required. Clean installation surface, peel adhesive backing from conduit, then press firmly into place.

iii. Insert ROPS harness ② into conduit ④.

iv. Provide adequate harness slack to allow light base to easily pass through cutout in roof liner (if applicable; see previous Step 4). Secure harness to B-pillar cross-member using three cable ties ⑥, and to front roof using two edge clips ③.

Ensure harness is routed and secured to prevent contact with hot components, sharp edges, or moving parts.

d. Feed any excess ROPS harness length down through A-pillar, providing enough slack for harness to pass through notch ① in left forward corner of front liner (if applicable).

NOTE

Liner shown for reference only.

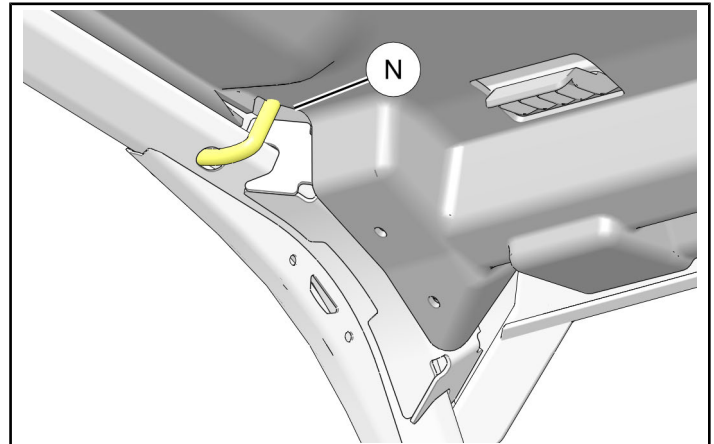

e. Route ROPS harness through notch ① in panel, then secure ROPS harness **AND** dash harness ① to main chassis harness using four cable ties ⑥, coiling excess harness as required.

Ensure harness is routed and secured to prevent contact with hot components, sharp edges, or moving parts.

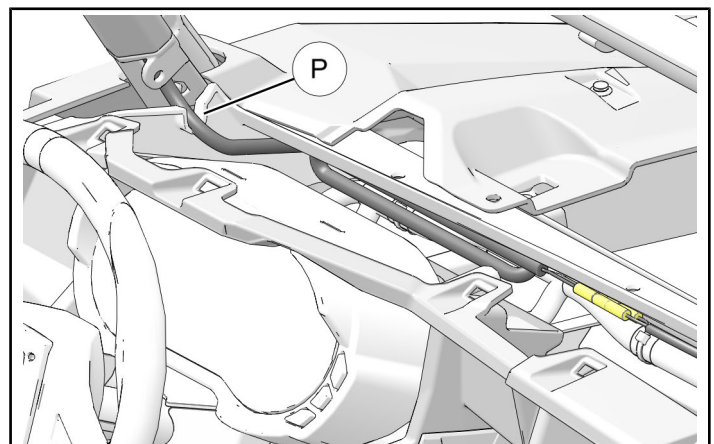

7. **If liner will be installed:** Detach removable portion of light from base per separate operation instructions (included), pass light down through opening in liner, then reinstall liner(s) in reverse order of removal. See Step 3d.
8. Install light 2A to roof using two screws ⑤. Do not overtighten screws.

9. Restore remaining access. See Steps 3a-3c.
10. Reconnect black negative (-) cable to battery, then reinstall battery access cover and seat.

NOTE

Shown with liner installed; installation without liner similar.

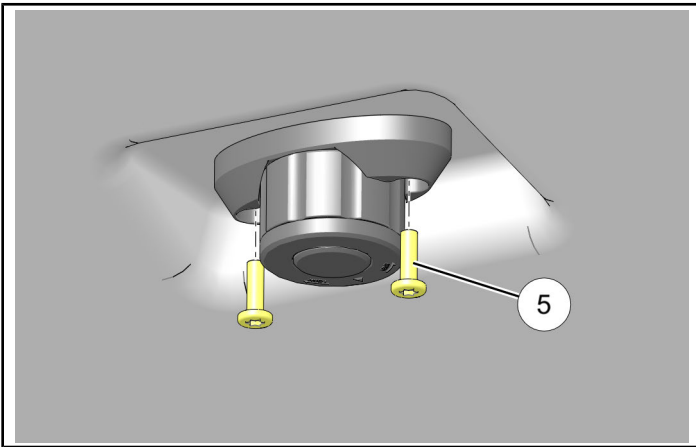

FEEDBACK FORM

A feedback form has been created for the installer to provide any comments, questions or concerns about the installation instructions. The form is viewable on mobile devices by scanning the QR code or by clicking [HERE](#) if viewing on a PC.

FEEDBACK FORM

