

# CREW REAR DOOR KIT



P/N 2883632; 2883633; 2884278

## MISSING OR DAMAGED PARTS

Before beginning assembly, inspect the kit and its component(s) to be sure all parts and tools are accounted for and not damaged. If missing parts or parts are damaged, please contact your Selling Dealer for assistance.

If your accessory was purchased online, please contact POLARIS® customer service at **1-800-POLARIS** (US & Canada only).

## APPLICATION

Verify accessory fitment at [Polaris.com](https://www.polaris.com).

## KIT CONTENTS

### NOTE

The LOWER CHASSIS-SIDE hinges required to install these REAR doors are not included in this kit. They are included in Front Door Kit 2882901, 2883229 (or equivalent), and are also available in service kit 2207871. See section **INSTALLATION INSTRUCTIONS**, Step 3, for detail.

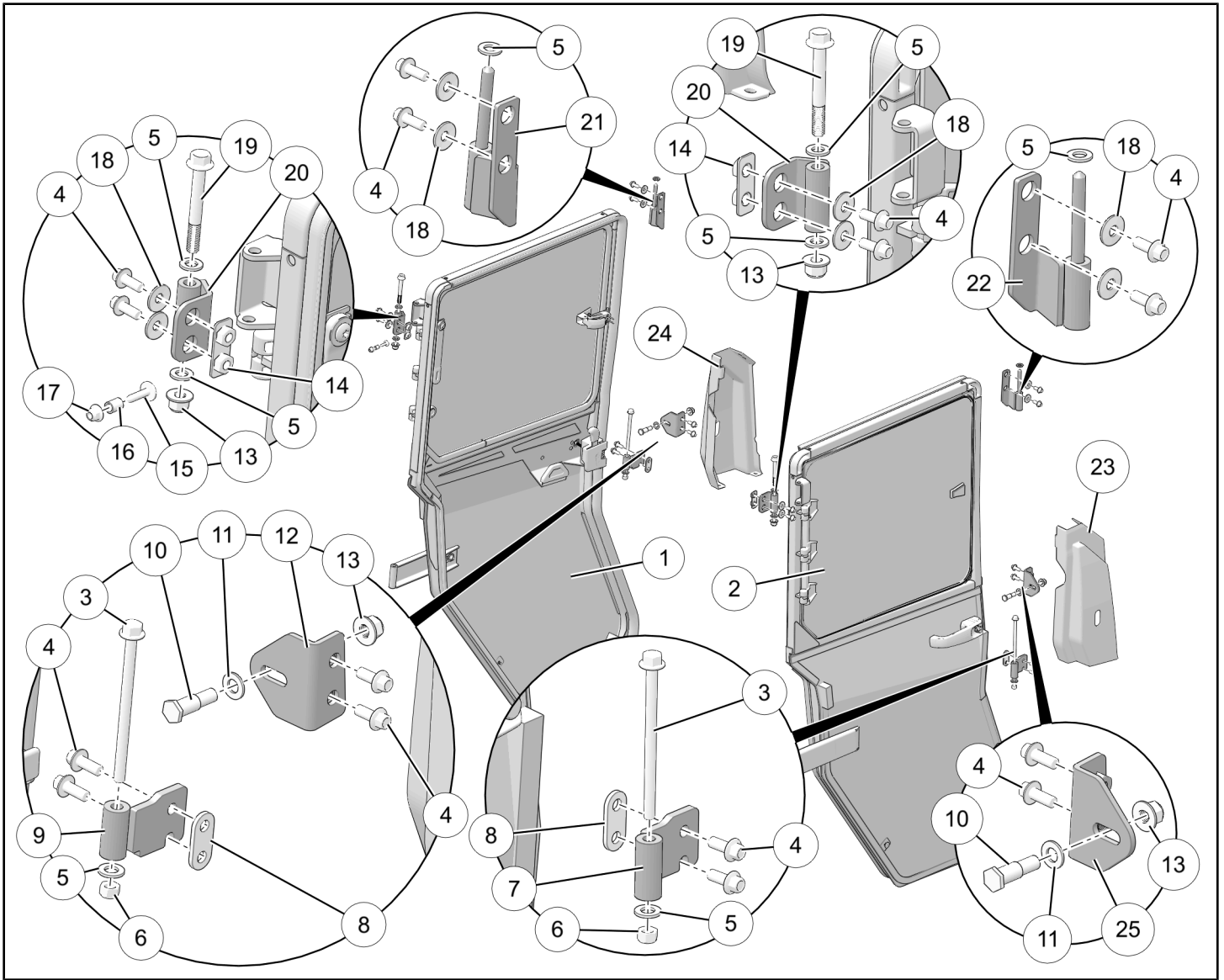

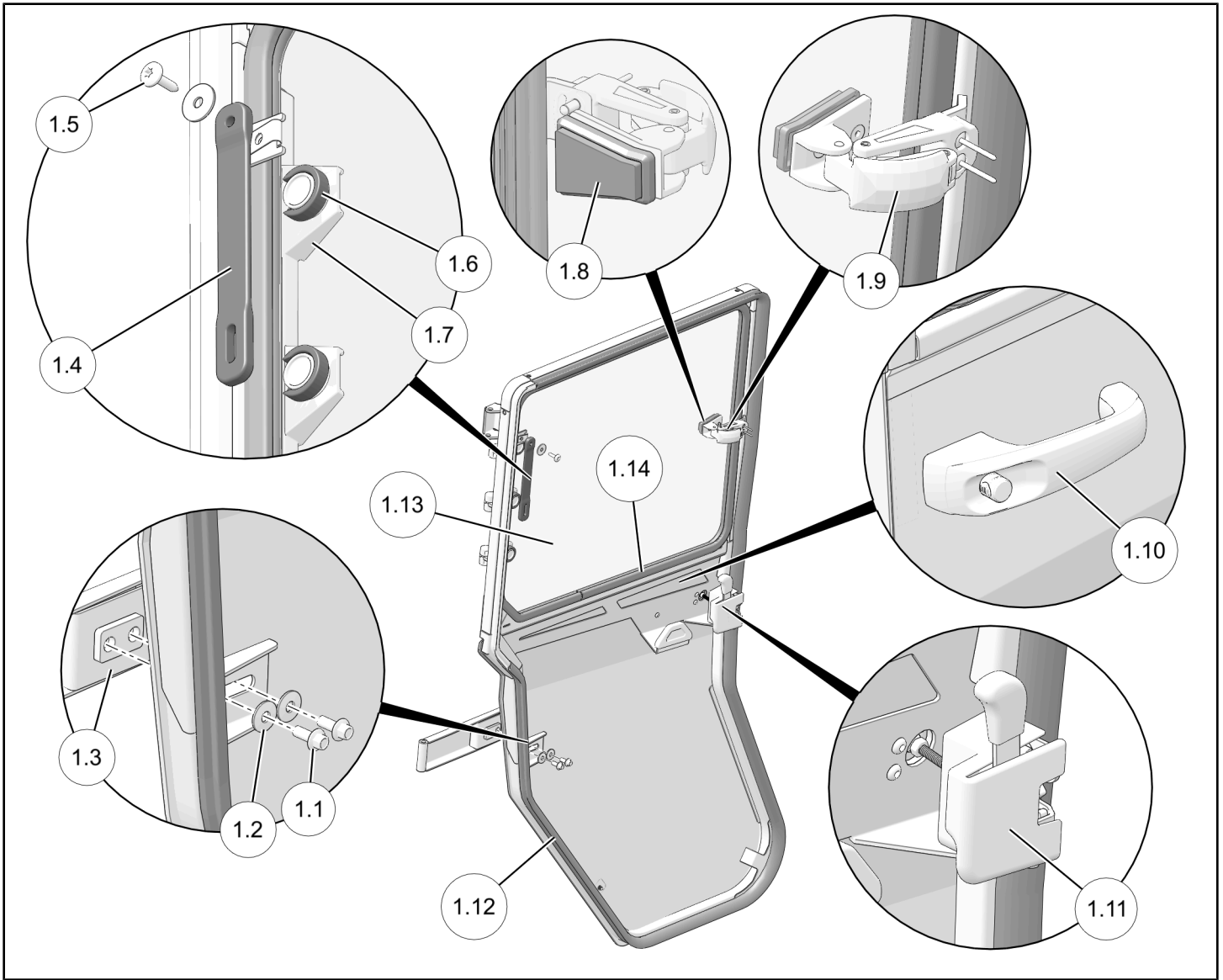

REF	QTY	PART DESCRIPTION	PART NUMBER	INCLUDED IN SERVICE KIT
1	1 1	Door Assembly, Left (includes items 1.1–1.14) Clear (P/N 2883632 only) Camo (P/N 2883633 only)	2637237 2637238	n/a n/a
1.1	2	- Screw, Hex Flange, M8 X 1.25 X 20 mm	7519936	2207871
1.2	2	- Washer, Conical Spring	n/a	2207871
1.3	1	- Hinge, Door Side, Lower Left	n/a	2207871
1.4	1	- Strap, Limiter	n/a	2205280
1.5	1	- Screw, Torx® Truss Head, M6 X 1.0 X 25 mm	7519650	2205280
1.6	3	- Clip, Hinge Retention	n/a	2207873*
1.7	1	- Hinge, Window	n/a	2207873*
1.8	1	- Base, Latch	n/a	2207873*
1.9	1	- Latch (includes mounting hardware)	n/a	2207873*

REF	QTY	PART DESCRIPTION	PART NUMBER	INCLUDED IN SERVICE KIT
1.10	1	- Handle, Exterior (includes mounting hardware)	n/a	2207880*
1.11	1	- Handle and Latch Assembly, Interior, Left (includes cover and mounting hardware)	n/a	2207878
1.12	1	- Seal, Door, Perimeter, Left	n/a	2207877
1.13	1	- Glass, Left	n/a	2207874
1.14	1	- Seal, Glass, Perimeter	n/a	2207876*
2	1 1	Door Assembly, Right (includes items 2.3, 2.11–2.13; all <b>other</b> right side parts same as left side parts) Clear (P/N 2883632 only) Camo (P/N 2883633 only)	2637249 2637250	n/a n/a
2.3	1	- Hinge, Door Side, Lower Left (not shown)	n/a	2207871
2.11	1	- Handle and Latch Assembly, Interior, Right (includes cover and mounting hardware) (not shown)	n/a	2207879
2.12	1	- Seal, Door, Perimeter, Right (not shown)	n/a	2207877
2.13	1	- Glass, Right (not shown)	n/a	2207875
3	2	Screw, Hex Flange, M8 X 1.25 X 120 mm	7519818	2207872
4	20	Screw, Hex Flange, M8 X 1.25 X 20 mm	7519936	2207871, 2207872
5	10	Washer, Nylon, 10.25 X 19.0 X 2.0 mm	5439712	2207871, 2207872
6	2	Nut, Hex, Locking, M8 X 1.25 mm	7547480	2207872
7	1	Hinge, Chassis-Side, Lower RH (front door)	n/a	2207872
8	2	Spacer	5265312	2207872
9	1	Hinge, Chassis-Side, Lower Left (front door)	n/a	2207872
10	2	Pin, Striker	n/a	2207871
11	2	Washer - M10	n/a	2207871
12	1	Bracket, Striker, Left	n/a	2207871
13	4	Nut, Hex Flange, Locking, M10 X 1.5 mm	n/a	2207871
14	2	Nut Plate, Upper Chassis-Side Hinge	5256140	2207871
15	2	Screw, Torx® Truss Head, M6 X 1.0 X 25 mm	7519650	2205280
16	2	Spacer	5139193	2205280
17	2	Nut, Hex Flange, Locking, M6 X 1.0 mm	7547339	2205280
18	8	Washer, Conical Spring	n/a	2207871, 2207872
19	2	Screw, Hex Flange, M10 X 1.5 X 80 mm	n/a	2207871
20	2	Hinge, Chassis-Side, Upper	n/a	2207871
21	1	Hinge, Chassis-Side, Upper Left (front door)	n/a	2207872
22	1	Hinge, Chassis-Side, Upper Right (front door)	n/a	2207872

REF	QTY	PART DESCRIPTION	PART NUMBER	INCLUDED IN SERVICE KIT
23	1	Cover, B-Pillar, Right	5454373-070	n/a
24	1	Cover, B-Pillar, Left	5454372-070	n/a
25	1	Bracket, Striker, Right	n/a	2207871

\* Service kit contains parts and hardware required for ONE side of vehicle.

## TOOLS REQUIRED

- Safety Glasses
- Pliers, Push Pin Rivet
- Screwdriver Set, Torx®
- Socket Set, Hex Bit, Metric
- Socket Set, Metric
- Socket Set, Torx® Bit
- Torque Wrench
- Wrench Set, Metric

## CONSUMABLES REQUIRED

- Gloves, Chemical Resistant
- Grease, Polaris All Season (or equivalent)

## IMPORTANT

Your Crew Rear Door Kit is exclusively designed for your vehicle. Please read the installation instructions thoroughly before beginning. Installation is easier if the vehicle is clean and free of debris. For your safety, and to ensure a satisfactory installation, perform all installation steps correctly in the sequence shown.

## INSTALLATION INSTRUCTIONS

### IMPORTANT

Polaris recommends completing installation Steps 1–3 of this Crew Rear Door Kit **PRIOR TO** installing Front Door Kit (2882901, 2883229, or equivalent). Installation of FRONT door hinges on **crew** vehicles is different from installation on **non-crew** vehicles. See Step 3 for detail.

### NOTE

Polaris recommends two people install this kit.

1. Shift vehicle transmission into “PARK”. Turn ignition switch to “OFF” position and remove key.
2. Open vehicle bed.

3. Install **FRONT** chassis-side hinges.

**IMPORTANT**

The LOWER chassis-side hinges included in this Crew REAR Door Kit will be used on the FRONT doors. Conversely, the LOWER chassis-side hinges included in the FRONT Door Kit will be used on the Crew REAR doors.

Swapping hinges is required to accommodate different hinge mounting structure between crew and non-crew vehicles.

As a result, do NOT follow front door hinge installation instructions included in the Front Door Kit. Follow these instructions instead.

- a. Identify upper **LH** chassis-side hinge (21). Notice differences from upper **RH** chassis-side hinge (22).

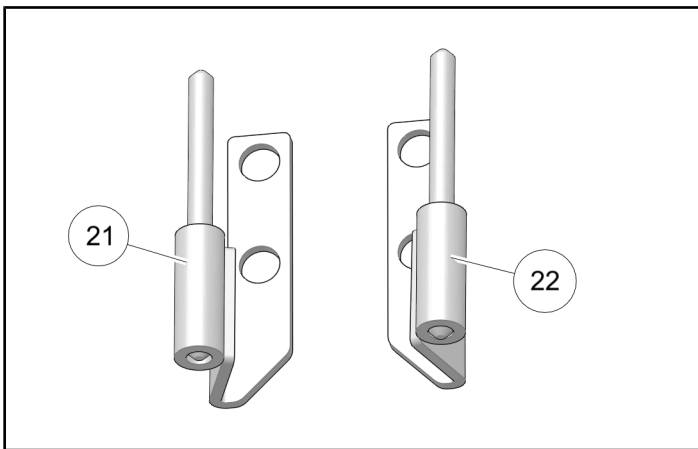

- b. Loosely install upper LH chassis-side hinge (21) to B-pillar fitting using two each screws (4) and washers (18). Ensure cupped-side of washer is towards hinge.

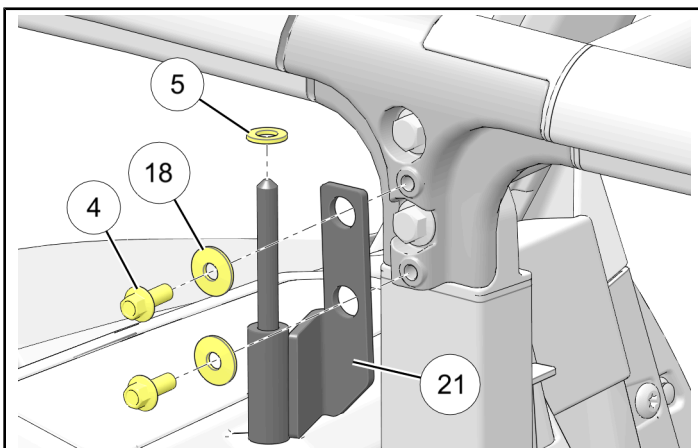

- c. Install nylon washer (5) to hinge pin.

**NOTE**

Washer acts as bearing surface to assist in smooth door operation.

- d. Remove two screws (A) from top of existing B-pillar cover. Retain screws.

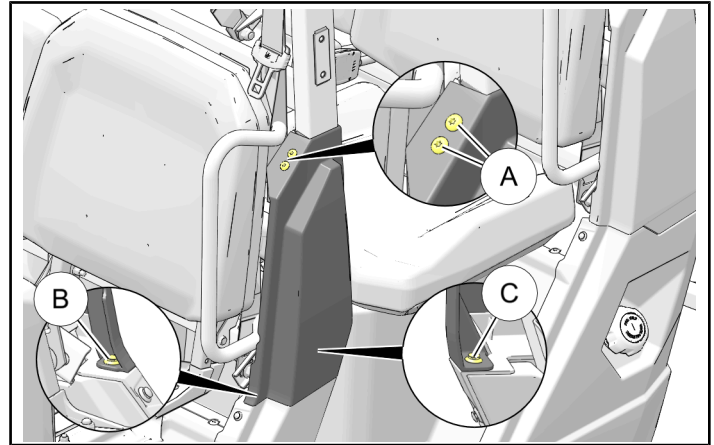

- e. Remove two push pin rivets from bottom interior of B-pillar cover (front rivet (B) and rear rivet (C)), then remove cover. Retain rivets. Cover will not be reused.

- f. Install new B-pillar cover (24) using retained screws (A) and push-pin rivets (B) and (C).

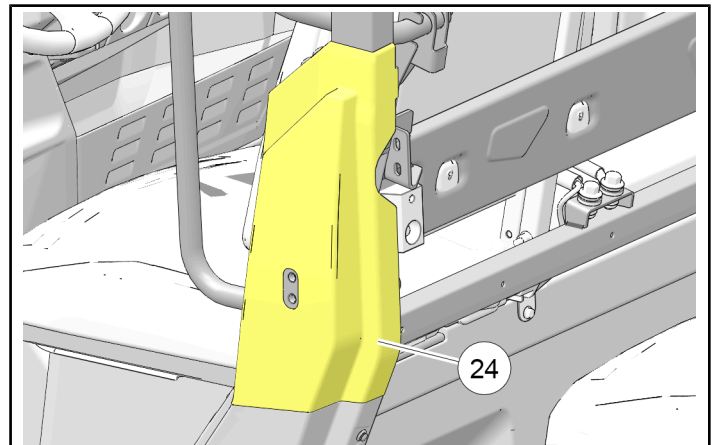

- g. Identify lower **LH** chassis-side hinge (9). Notice differences from lower **RH** chassis-side hinge (7).

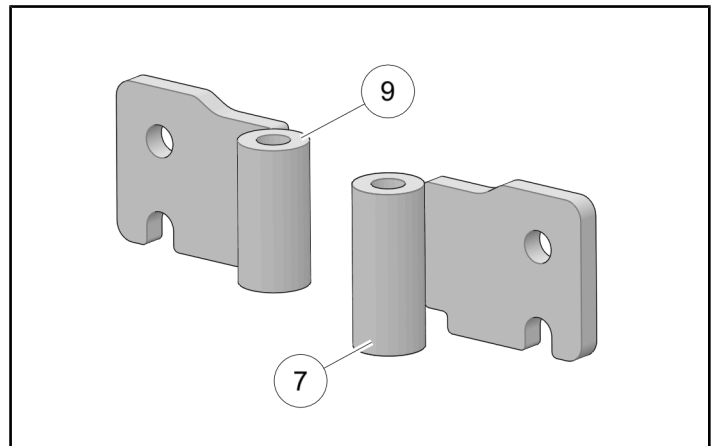

- h. Loosely install spacer ⑧ and lower LH chassis-side hinge ⑨ to B-pillar fitting using two screws ④.

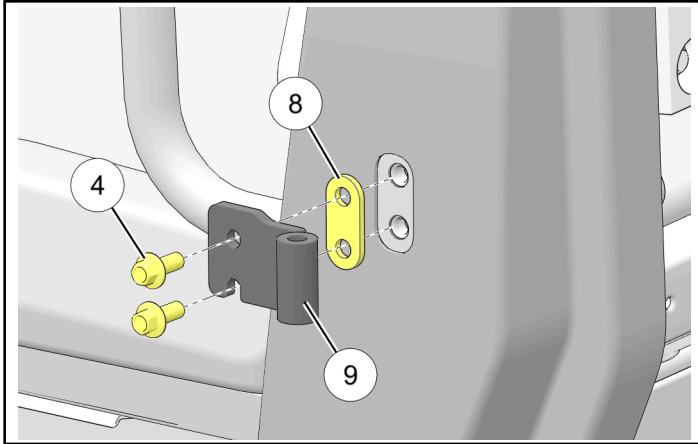

- k. Continue with front door installation per instructions provided with Front Door Kit. Torque all four hinge screws ④ to specification.

### TORQUE

17 ft. lbs. (23 Nm) ± 10%

4. Install **REAR** chassis-side hinges.

- a. Loosely install upper chassis-side hinge ⑳ to C-pillar fitting using two each screws ④ and washers ⑱, and nut plate ⑭. Ensure cupped-side of washer is towards hinge.

### NOTE

Upper chassis-side hinge ⑳ is identical for LH and RH sides.

### ⚠ WARNING

Follow all chemical manufacturer instructions and safety precautions. Failure to follow all manufacturer instructions and precautions may result in severe injury or death.

- i. Grease screw ③ and pin on upper chassis-side hinge ㉑ with Polaris All Season Grease (or equivalent).
- j. Hang front door assembly on upper chassis-side hinge ㉑. Align door with lower chassis-side hinge ⑨, insert nylon washer ⑤ between chassis and door-side hinges as shown, then install screw ③.

Secure with nut ⑥. Torque to specification.

### TORQUE

8 ft. lbs. (11 Nm) ± 20%

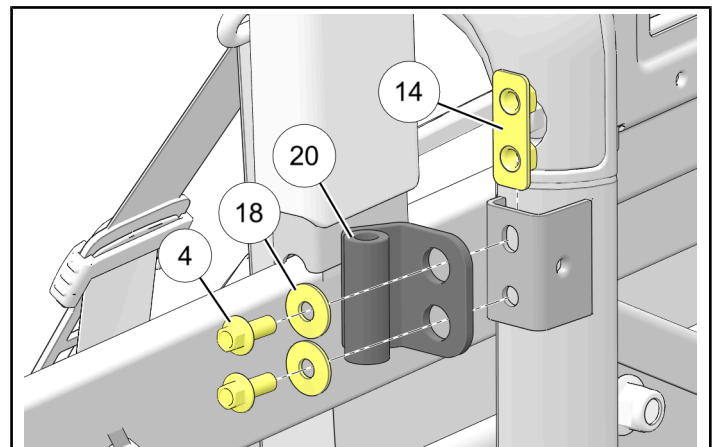
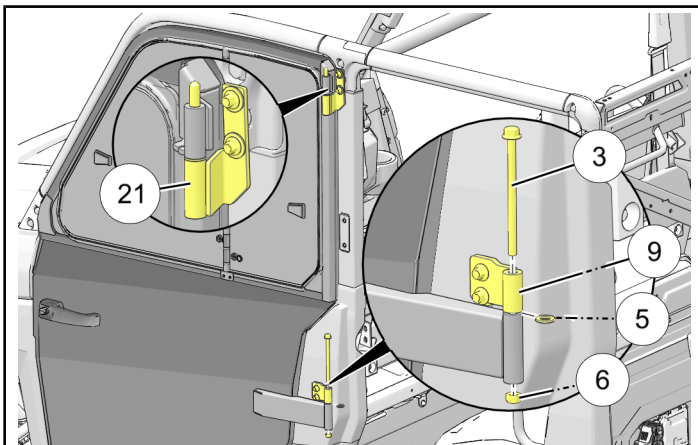

- b. Locate the following parts included in the **FRONT DOOR KIT**:

- Lower **LH** chassis-side hinge ①
- Lower **RH** chassis-side hinge ②

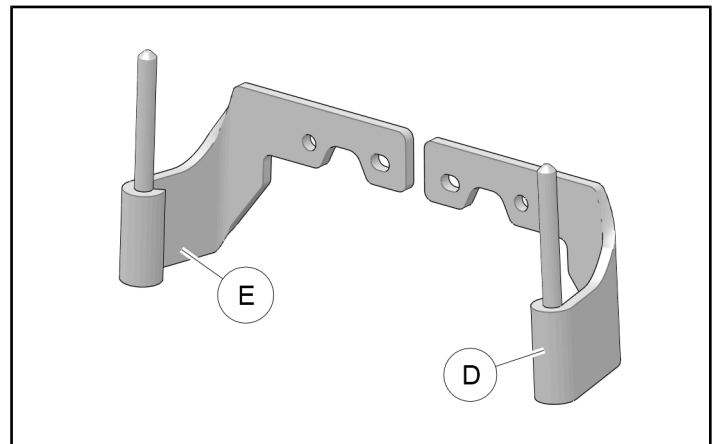



- c. Loosely install lower LH chassis-side hinge ⑩ to chassis fitting using two screws ④.

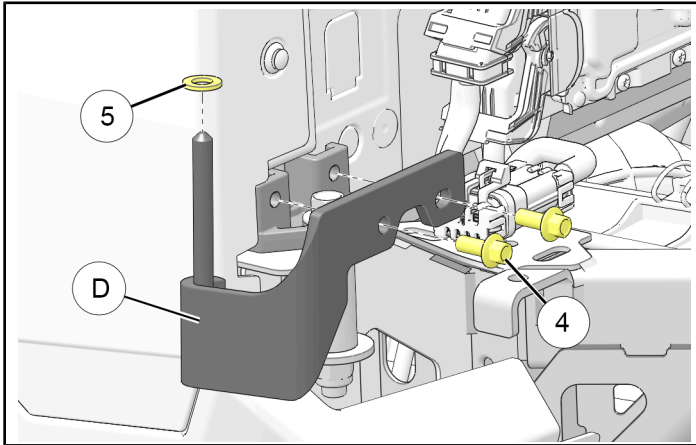

- d. Install nylon washer ⑤ to hinge pin.

### ⚠ WARNING

Follow all chemical manufacturer instructions and safety precautions. Failure to follow all manufacturer instructions and precautions may result in severe injury or death.

5. Grease screw ⑲ and pin on lower chassis-side hinge ⑩ with Polaris All Season Grease (or equivalent).
6. Hang rear door assembly ① on lower chassis-side hinge ⑩. Align door with upper chassis-side hinge ⑳, insert two nylon washers ⑤ between chassis and door-side hinges as shown, then install screw ⑲.

Secure with nut ⑬. Torque to specification.

### TORQUE

8 ft. lbs. (11 Nm) ± 20%

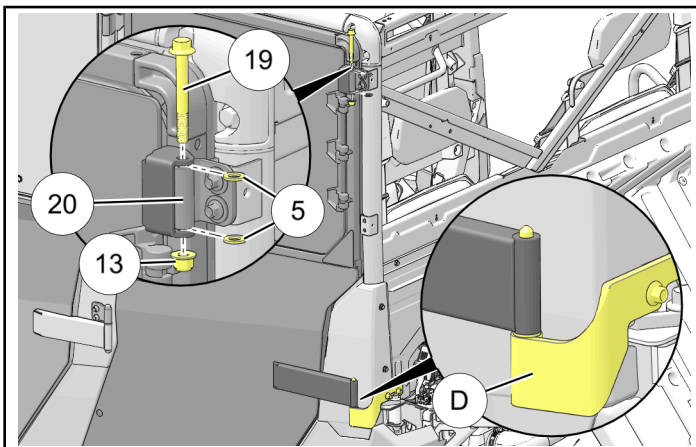

7. With upper and lower chassis-side hinge screws slightly loose, close door.

Push door inwards while attempting to center door in ROPS/chassis opening. Hold door in place, then observe gap between door assembly ① and ROPS/chassis (around entire perimeter of door).

- **IF PERIMETER GAP IS EVEN:** Look to see if gap exists between bottom of LOWER chassis-side hinge ⑩ and corresponding door-side hinge ①. If hinge gap exists, adjust height of UPPER chassis-side hinge ⑳ to eliminate gap and equalize hinge loading. Tighten screws ④.

### NOTE

If necessary, remove one or more nylon washers ⑤ to eliminate hinge gap.

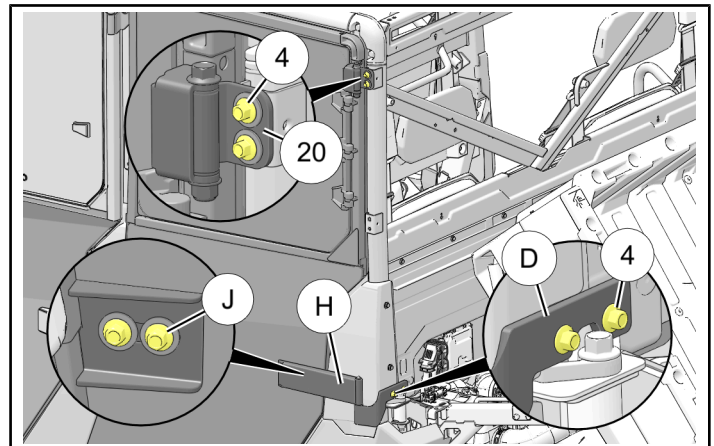

- **IF PERIMETER GAP IS UNEVEN:** Loosen two lower DOOR-SIDE hinge screws ① (interior of door), center door in opening using slotted fastener openings, then re-tighten same screws.

When complete, go to previous bullet, **IF PERIMETER GAP IS EVEN.**

### TIP

Have one person hold and center the door, and a second person tighten the screws.

8. Torque all four chassis-side hinge screws ④ (and door-side hinge screws ①, if loosened) to specification.

### TORQUE

17 ft. lbs. (23 Nm) ± 10%



9. Assemble and install striker.

- a. Identify **LH** striker bracket ⑫. Notice differences from **RH** striker bracket ⑮.

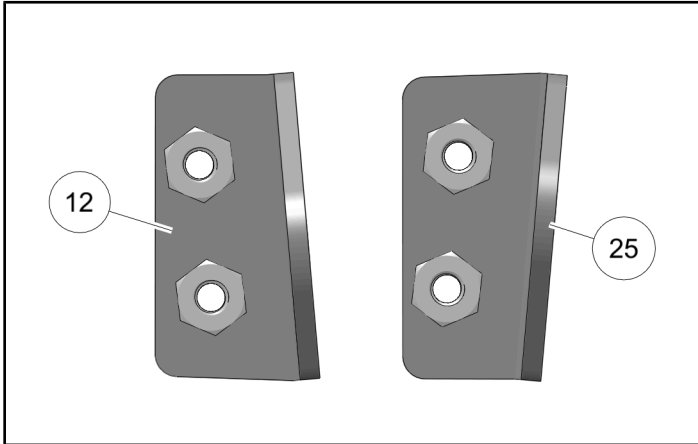

- b. Install striker pin ⑩ and washer ⑪ to LH striker bracket ⑫ using nut ⑬. Center pin in slot, then tighten nut.

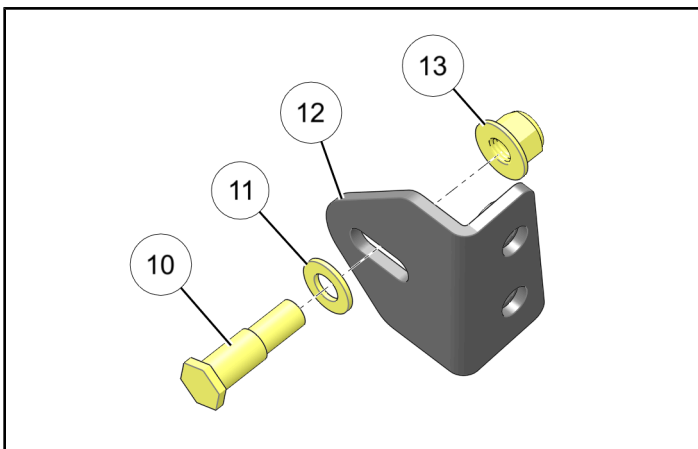

- c. Install LH striker bracket ⑫ to chassis using two screws ④. Center bracket in slots, then tighten screws.

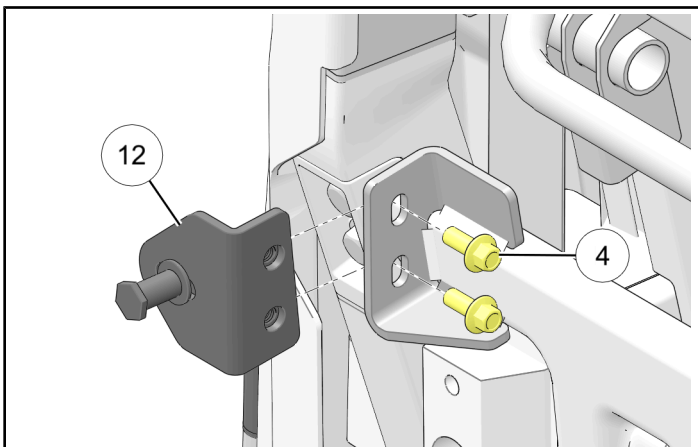

10. Open door latch (to properly position pawls), then slowly close door and observe engagement of striker pin ⑩ into door latch.

Adjust striker pin and/or striker bracket ⑫ to achieve the following:

- a. **HEIGHT** ⑰: Pin ⑩ should be centered vertically in opening of latch frame ⑱. To adjust, loosen two screws ④, slide striker bracket ⑫ up or down as required, then retighten screws.

**NOTE**

Latch cover hidden for clarity.

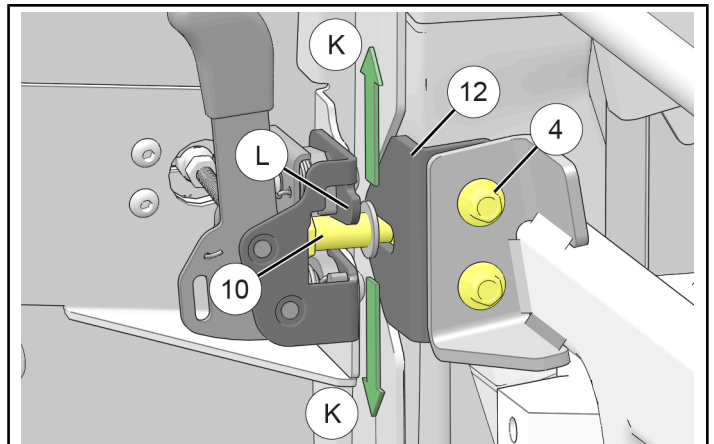

- b. **DEPTH** ⑲: As required to achieve desired fairing between door assembly ① and ROPS/chassis structure. To adjust, loosen nut ⑬, slide striker pin ⑩ inboard or outboard as required, then retighten nut.

Ensure depth adjustment is made with latch pawl ⑲ at FULL closure as shown (second “click”), not at partial closure (first “click”).

**NOTE**

Nut can be accessed by reaching up from below striker bracket.

Bracket shown partially transparent for clarity.

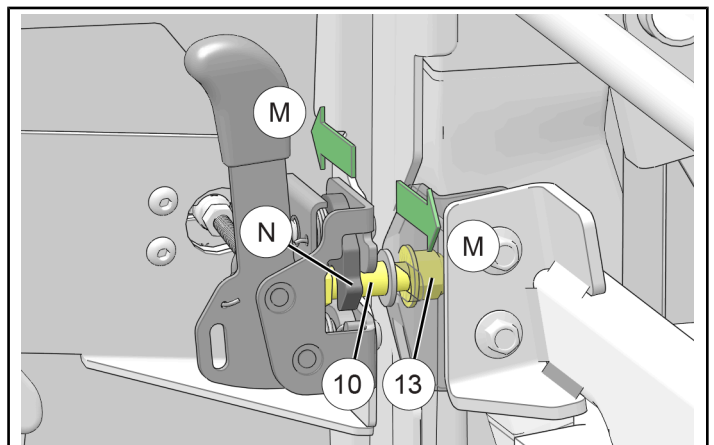

11. Torque striker screws ④ to specification.

**TORQUE**

17 ft. lbs. (23 Nm) ± 10%

12. Torque striker nut ⑬ to specification.

**TORQUE**

30 ft. lbs. (41 Nm) ± 10%

13. Install limiter strap retaining post to ROPS diagonal support using screw ⑮, spacer ⑯, and nut ⑰. Torque to specification, then secure strap ⑰ to post.

**TORQUE**

7 ft. lbs. (9 Nm) ± 10%

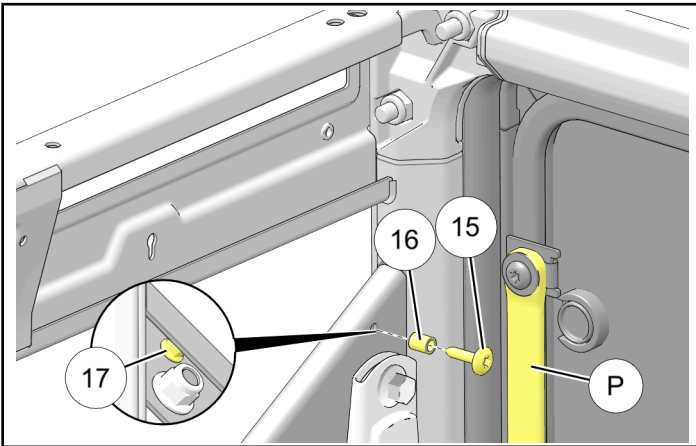

14. Repeat Steps 3–13 for RH door assembly ②, using lower RH chassis-side hinge ⑦, upper RH chassis-side hinge ⑧, RH B-pillar cover ③, and RH striker bracket ⑤.

15. Lower vehicle bed.