

AUTOSTOP KIT



P/N 2881288; 2881289

APPLICATION

Verify accessory fitment at Polaris.com.

BEFORE YOU BEGIN

Read these instructions and check to be sure all parts and tools are accounted for. Please retain these installation instructions for future reference and parts ordering information.

KIT CONTENTS

This Kit includes:

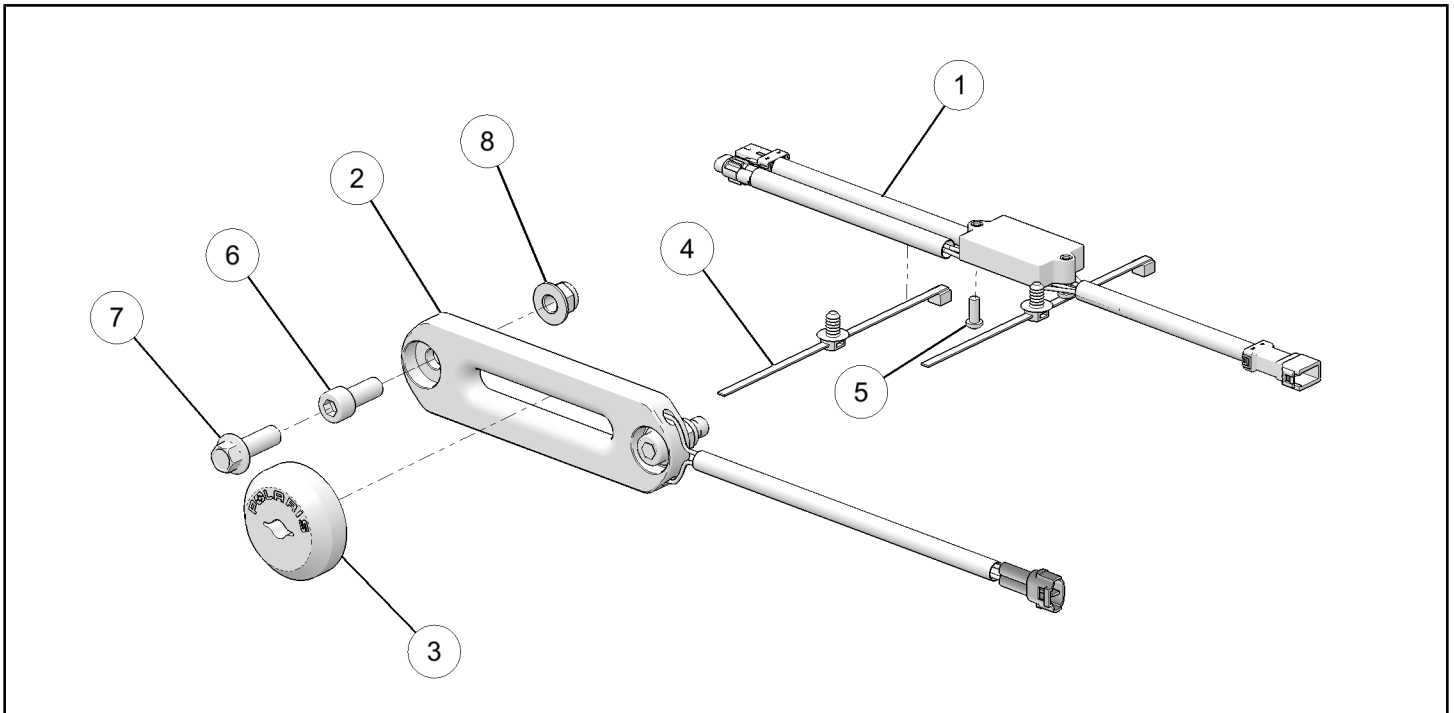

REF	QTY	PART DESCRIPTION	PART NUMBER
1	1	Control Fairlead Kit	2206067
2	1	Fairlead Kit (PN 2881288)	5140384
		Fairlead Kit (PN 2881289)	5140385
3	1	Stop-Magnet, Bumper, Rubber	5415787
4	2	Routing Clip	7081496
5	2	Screw #10 X 1/2	7518238
6	2	Screw - M10 X 1.5 X 25	7517358
7	2	Screw - M10 X 1.5 X 30	7517425
8	2	Nut - M10 X 1.5	7547423
	1	Instructions	9926644

TOOLS REQUIRED

- 13 mm Socket and Ratchet
- 8 mm Allen Wrench
- Pliers
- T-25 Torx Driver

IMPORTANT

Your AUTOSTOP KIT is exclusively designed for your vehicle. Please read the installation instructions thoroughly before beginning. Installation is easier if the vehicle is clean and free of debris. For your safety, and to ensure a satisfactory installation, perform all installation steps correctly in the sequence shown.

FUNCTION OF THE AUTOSTOP FEATURE

The AutoStop fairlead is an innovative solution making your winch easier to use, especially when plowing. The hardest work your winch does is when it isn't doing much work at all; when your winch pulls the rope tight to get the last bit of lift out of the plow or to tighten up the hook to prevent it from rattling against the bumper. As the winch pulls the hook against the fairlead it stresses the winch, rope, fairlead, and vehicle frame. To help prevent damage to these components, Polaris created a solution that stops the winch before the hook is pulled too far into the fairlead.

If your vehicle is equipped with this feature it contains an aluminum Hawse-type fairlead, a rubber bump stop that contains magnets, and a wire harness with a control box. This winch is only for use with synthetic rope, as a steel cable would quickly wear and damage the aluminum fairlead. If your vehicle is equipped with steel cable, you will need to order a synthetic rope. For 4500 models order kit PN 2879187; for 3500/2500 models order kit PN 2878888. When the rubber bump stop is brought close to the fairlead, sensors inside the fairlead tell the control box to turn the winch off. The winch will continue to let rope out, but the rope will not pull in any further.

ASSEMBLY TIME

Approximately 60 minutes

INSTALLATION INSTRUCTIONS

1. To install this kit you will need to replace the roller fairlead with the aluminum Hawse fairlead included with this kit and install the control box. Both of these operations are fairly simple, but pay attention to the details described in the steps to ensure proper operation. Wire routing should be exceptionally easy as most of it has already been done for you. If you are installing a wireless remote at this time, refer to the wiring diagram in this kit and use the instructions in the wireless remote kit to aid in your installation.
2. Place vehicle in "PARK". Turn key to "OFF" position and remove from vehicle. Remove seats. Disconnect cables (black negative (B), red positive (A)) from battery.
3. Detach lower front fascia (C) by removing push rivets (D).

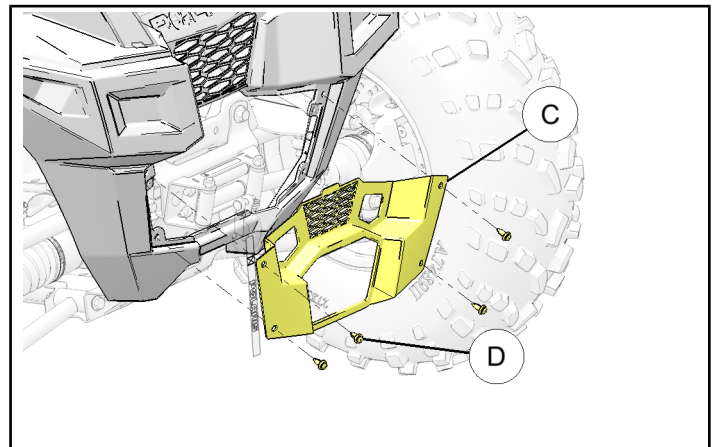
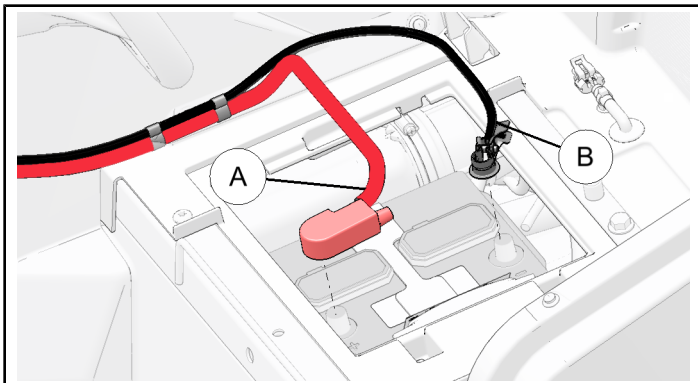

4. Remove the two nuts (E) and bolts (F) holding the roller fairlead onto fairlead mounting bracket.

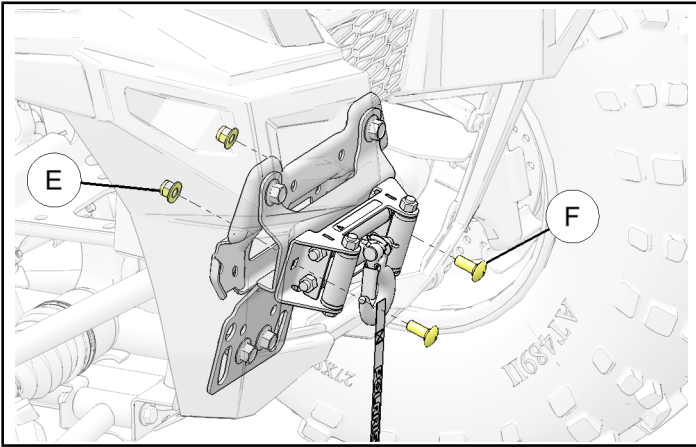

5. Remove the cotter pin (G) and clevis pin (H) from the hook to allow the rope to be pulled through the fairlead. If you have a wire rope, replace it with a synthetic rope at this time.

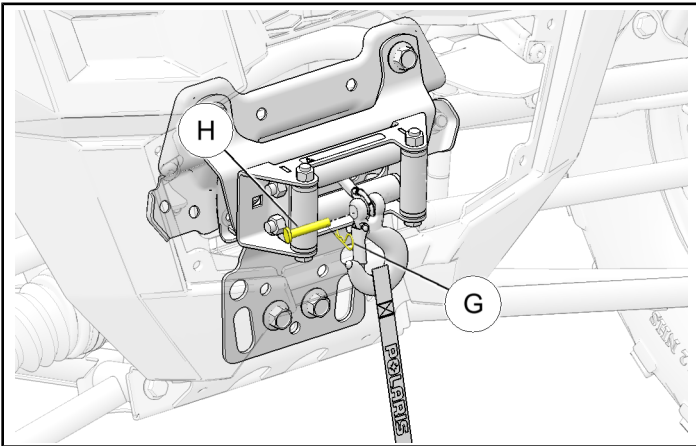

6. Thread the rope through the aluminum fairlead (2) so that the side with recessed holes (J) for the fasteners faces away from the vehicle. Using new screw (6) or (7) and nut (8) included with this kit, install the fairlead onto the machine with the wire (K) pointing toward the passenger side of the vehicle. You have the option of using a hex head or a socket head (Allen) bolt as both are included in this kit. Tighten fasteners.

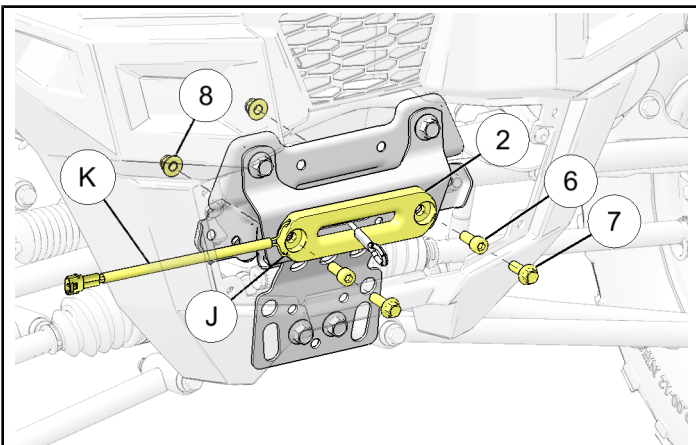

7. Thread the rope (L) through the rubber bump stop with the "POLARIS" label facing outward, away from the vehicle as shown. The rubber bump stop is supposed to be tight on the rope, so use a string or plastic cable tie, tied around the end of the rope to pull the rope through the bump stop. It is helpful to apply a small amount of rubbing alcohol or other non-corrosive lubricant to the rubber bump stop to ease the rope through the hole. Once the rope is through the hole, attach the hook to the rope with cotter pin and clevis as mentioned in Step 5.

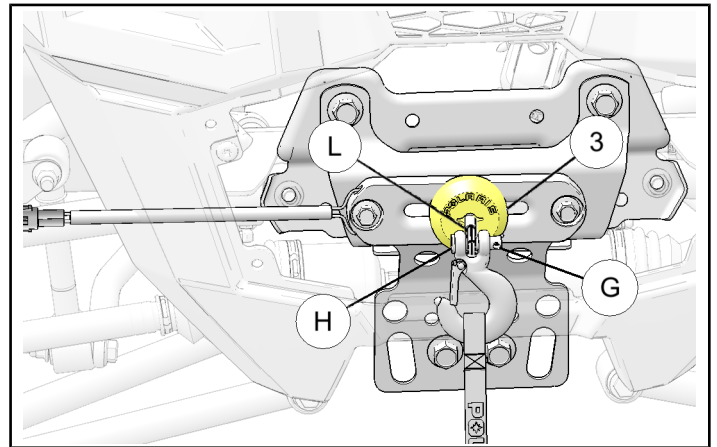

8. Install the control box (1) on the contactor mounting bracket by using the small plastic screws (5) included with this kit. Screws should go through the bracket into the white plastic housing. Tighten just until snug and do not over tighten.

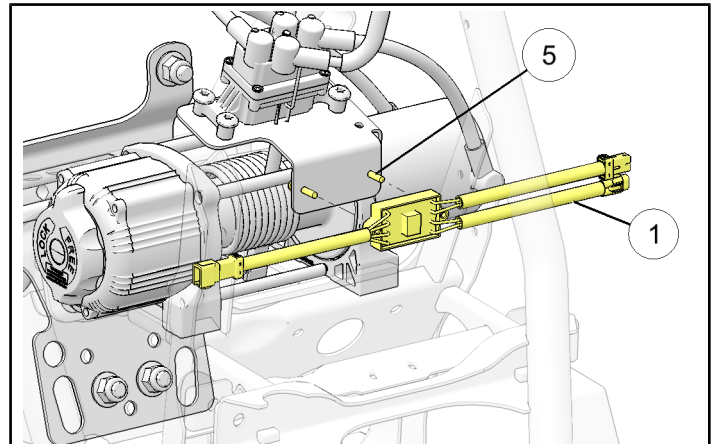

9. Disconnect the connection (N) between the vehicle wire harness and the contactor.

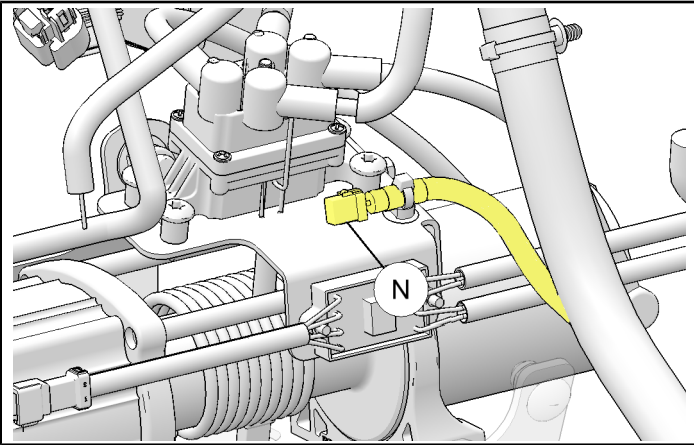

11. Connect the other end of the fairlead control box ① to the contactor.

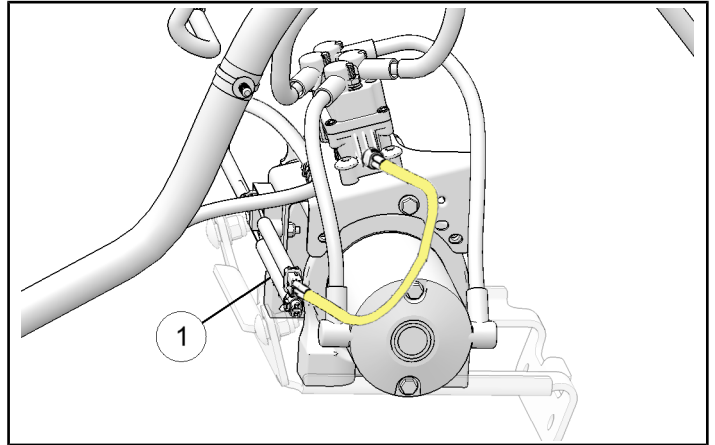

10. Reconnect the vehicle wire harness to the mating connector on the fairlead control box ①.

NOTE

If you are installing the wireless remote control kit (PN 2881287), connect it between the vehicle wire harness and fairlead control box.

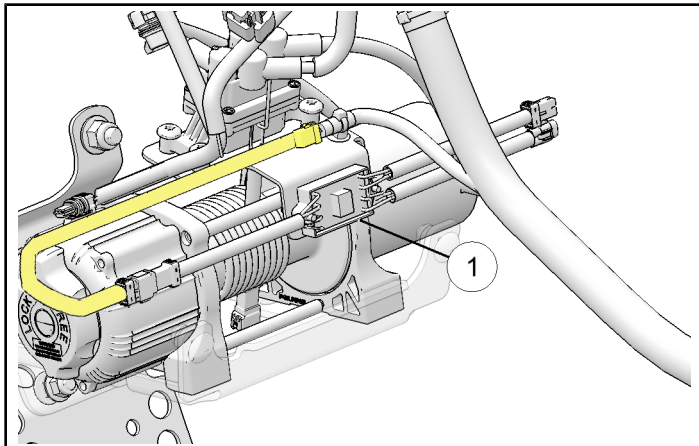

12. Finally, connect the fairlead ② to the fairlead control box ①. Secure all wires to the chassis or other fixed locations on the vehicle to prevent wires from contacting any moving parts on the winch.

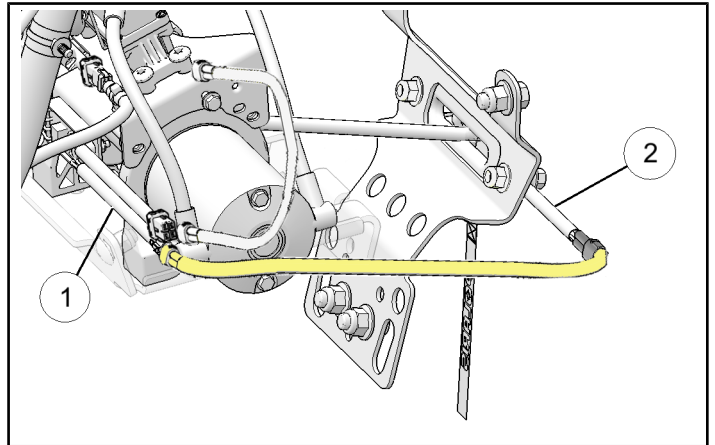

13. Reinstall lower front fascia removed in Step 3 using rivets.
14. Reconnect wires to battery terminals and reinstall seats.