

WHIP FLAG KIT



P/N 2881468

APPLICATION

RZR XP1000, RZR XP 4 1000, RZR 900, RZR S 900,
RZR S 4 900

BEFORE YOU BEGIN

Read these instructions and check to be sure all parts and tools are accounted for. Please retain these installation instructions for future reference and parts ordering information.

KIT CONTENTS

This Kit includes:

REF	QTY	PART DESCRIPTION	PART NUMBER
1	1	Whip flag	2636027
2	2	Washer, 8.4 x 24 x 2	—
3	1	Nut, M8 x 1.25	—
	1	Instructions	9926363

TOOLS REQUIRED

- Metric wrench kit

IMPORTANT

Your Whip Flag Kit is exclusively designed for your vehicle. Please read the installation instructions thoroughly before beginning. Installation is easier if the vehicle is clean and free of debris. For your safety, and to ensure a satisfactory installation, perform all installation steps correctly in the sequence shown.

ASSEMBLY TIME

Approximately 10 minutes

INSTALLATION INSTRUCTIONS

NOTE

Whip flag installation on RZR S 900 and RZR S 4 900 requires previous installation of either PN 2877502 (L&R Flag Mount) or 2878907 (Billet Flag Clamp), purchased separately. No flag mounting hole is provided on these vehicles.

CAUTION

Do not trailer vehicle with whip flag tied down or bent (such as to fit in enclosed trailer). Flag may break resulting in personal injury. Remove whip flag prior to transport.

1. Place vehicle in "PARK". Turn key to "OFF" position and remove from vehicle.

2. Insert whip flag ① through washer ② into vehicle as shown. Proper hole is identified by "FLAG".

NOTE

Whip flag can be installed on either left or right side, as desired.

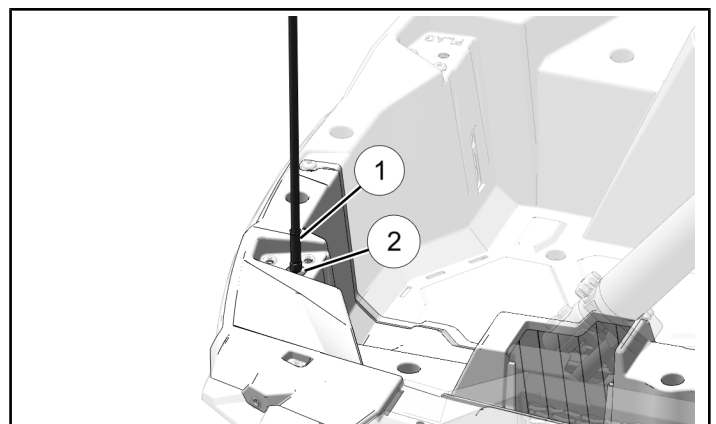

3. Install washer ② and nut ③ onto whip flag threaded base as shown. Tighten fastener.

NOTE

Bed liner not shown for clarity.

