

TIP-OUT GLASS WINDSHIELD KIT



P/N 2881108

APPLICATION

Verify accessory fitment at Polaris.com.

BEFORE YOU BEGIN

Read these instructions and check to be sure all parts and tools are accounted for. Please retain these installation instructions for future reference and parts ordering information.

KIT CONTENTS

This Kit includes:

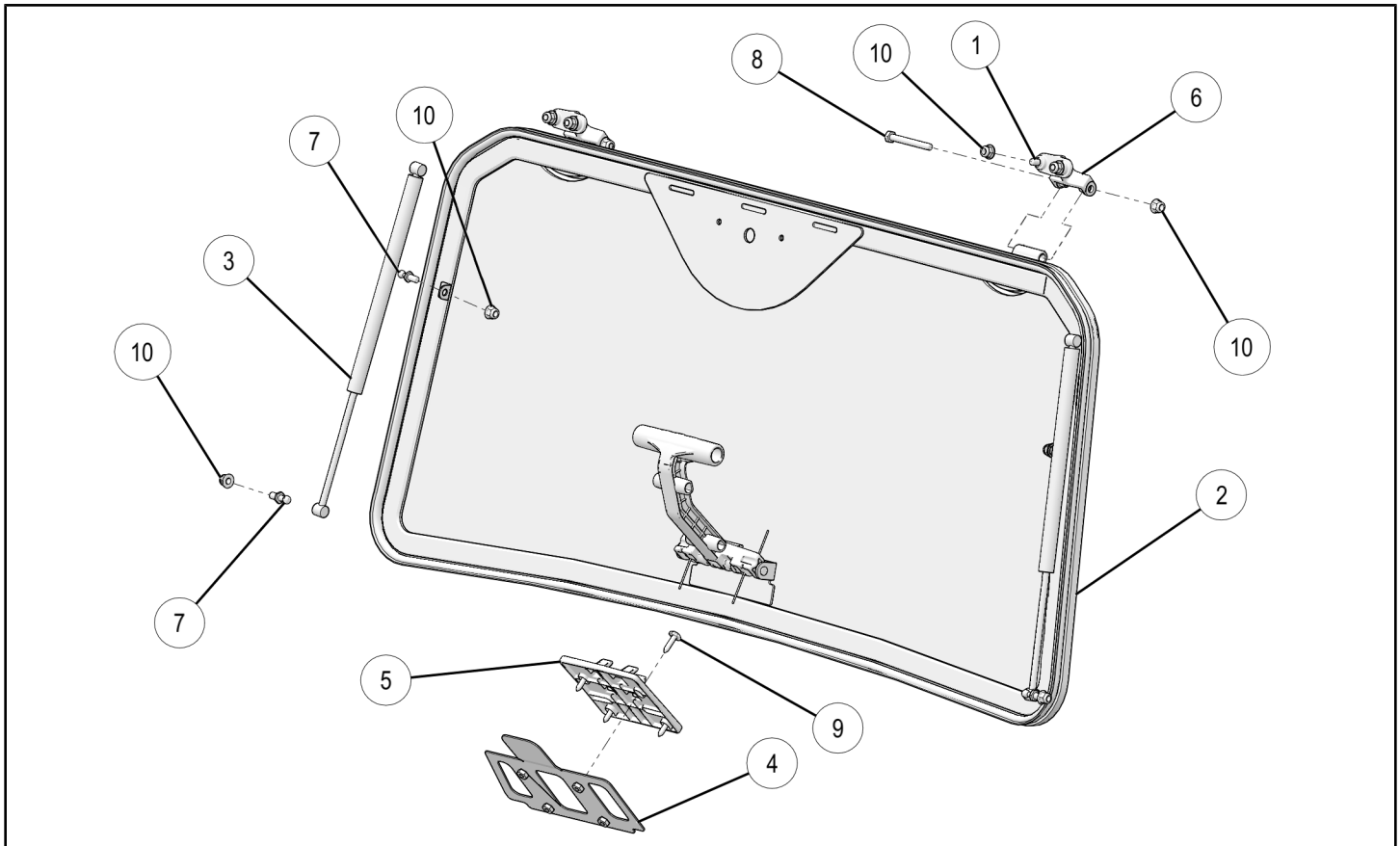

REF	QTY	PART DESCRIPTION	PART NUMBER	INCLUDED IN HARDWARE KIT
1	4	Stud, Welded - M8 X 1.25 X 30	-	2206350
2	1	Windshield	2635985	-
3	2	Shock	-	2206349
4	1	Backing Plate	5262665	2205983
5	1	Handle Base	5452826	2205983
6	2	Hinge Mount	5633492	2206350
7	4	Fitting, Ball - M8 X 1.25	7081839	2206349

REF	QTY	PART DESCRIPTION	PART NUMBER	INCLUDED IN HARDWARE KIT
8	2	Screw, Hex Head Cap - M8 X 1.25 X 70	7518992	2206350
9	4	Screw, Torx® - M6 X 1.0 X 25	7519650	2205983
10	10	Nut, Hex Flange - M8 X 1.25	7547454	2206349 (4 nuts) 2206350 (10 nuts)
	1	Instructions	9926166	-

TOOLS REQUIRED

- Safety Glasses
- Drill
- Drill Bits: 7 mm, 3/4 inch
- File, Round
- Torque Wrench
- Screwdriver Set, Torx®
- Screwdriver, Slotted
- Socket Set, Metric
- Wrench Set, Metric

IMPORTANT

Your TIP-OUT GLASS WINDSHIELD KIT is exclusively designed for your vehicle. Please read the installation instructions thoroughly before beginning. Installation is easier if the vehicle is clean and free of debris. For your safety, and to ensure a satisfactory installation, perform all installation steps correctly in the sequence shown.

ASSEMBLY TIME

Approximately 45 minutes

INSTALLATION INSTRUCTIONS

1. Place vehicle in "PARK". Turn key to "OFF" position and remove from vehicle.
2. Install ball fitting ⑦ to each lower ROPS A-pillar (LH and RH) using nut ⑩ as shown. Ensure proper orientation; ball should be inboard.
3. Install hinge mount ⑥ to each side of windshield ② using screw ⑧ and nut ⑩ as shown. Do not overtighten nut; windshield must be free to rotate.

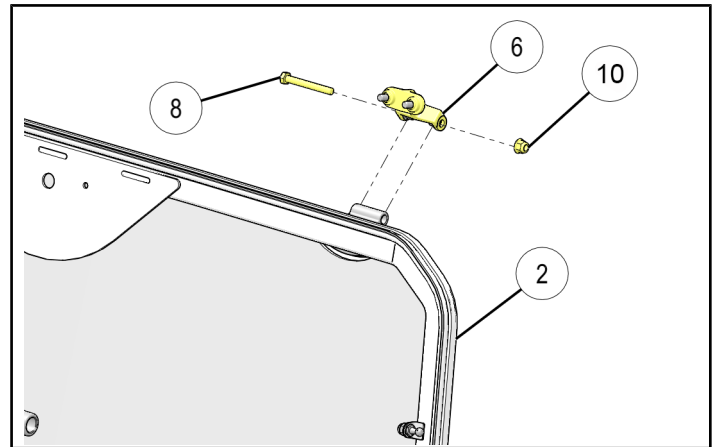
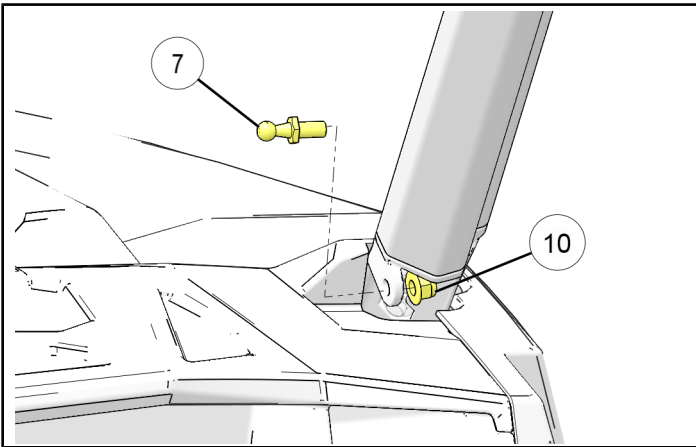

4. Drill hinge mount holes in visor panel.
 - a. Remove four screws (A) from upper visor panel as shown, then remove panel. Retain screws for reinstallation.

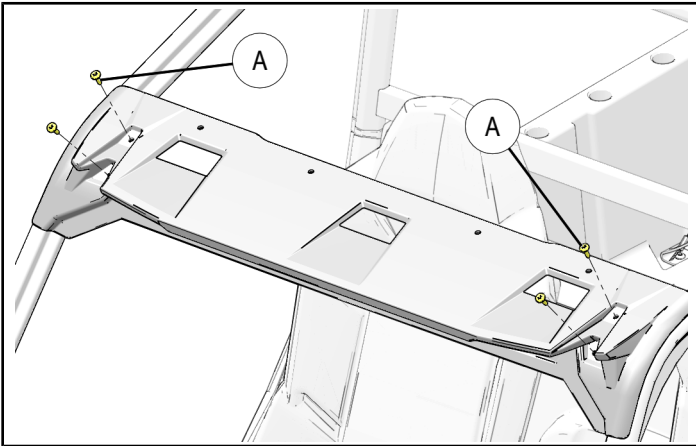

- b. Using 3/4 inch drill bit, drill marked locations on lower side of panel as shown for hinge mount ⑥ bosses. File to marked outline as required.

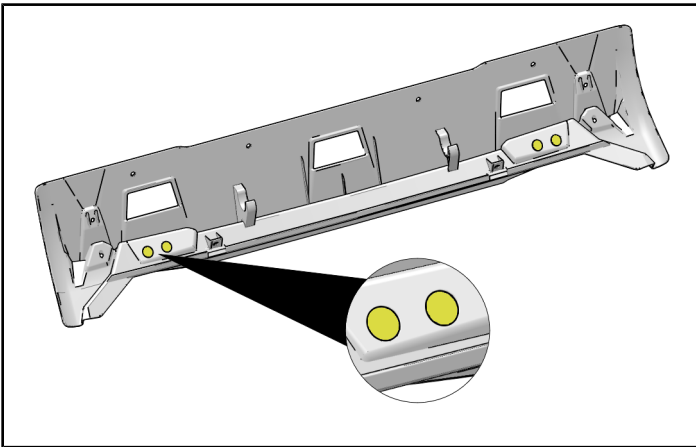

- c. Reinstall visor panel using retained screws.

5. Install hinge mount ⑥ studs through visor panel and ROPS brackets, then loosely install nuts ⑩ as shown. Center windshield in ROPS, then tighten nuts.

NOTE

Visor holes are large enough to allow hinge mount bosses to make metal-to-metal contact with ROPS brackets.

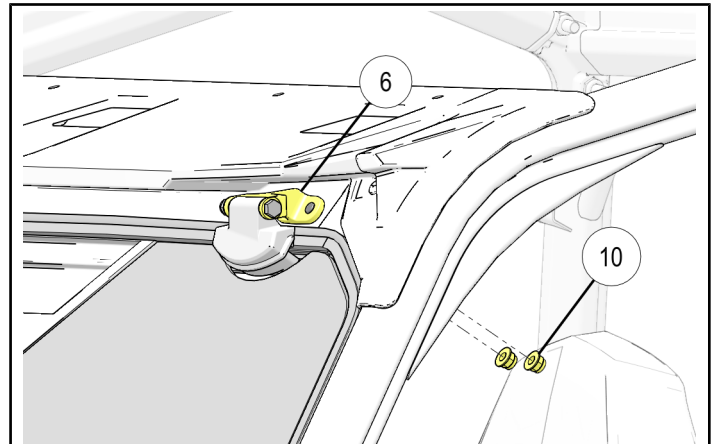

6. Close windshield and attach handle (B) to handle base ⑤ as shown. Ensure proper orientation of base: handle locking clips should be towards rear of dash, and handle should be centered in base.

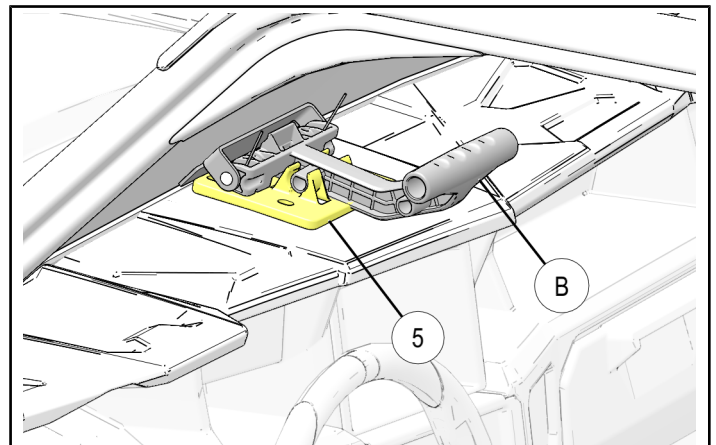

7. Ensure window is fully closed and centered, then use handle base ⑤ as template to mark four holes in upper dash panel (C) as shown.

NOTE

OPTIONAL: Rear two holes can be marked now, then front two holes marked after handle is detached from base (Step 8).

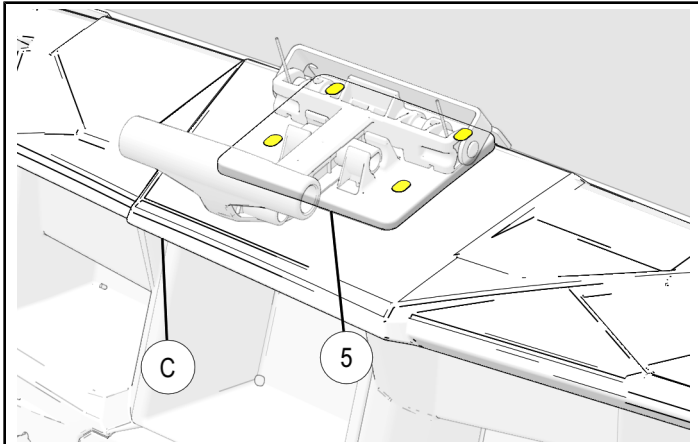

8. Detach handle (B) from handle base ⑤. Set base aside.
9. Install upper ends of shocks ③ to ball fittings ⑦ on windshield by firmly pushing shocks into fittings as shown. Retention clip will snap into place when shock is fully seated. Ensure proper orientation of shock; larger diameter shaft should be up.

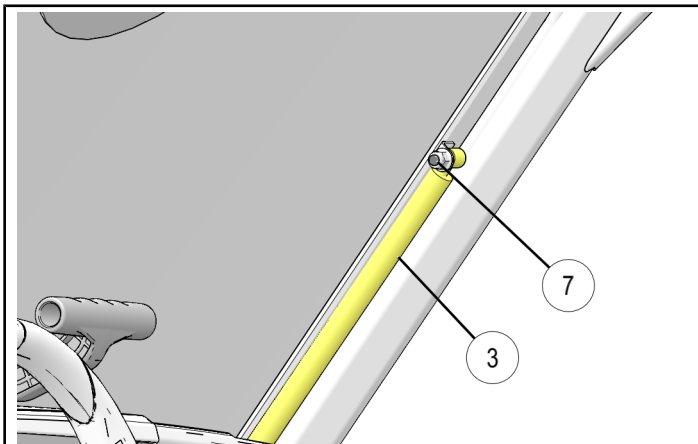

10. Open windshield and install lower ends of shocks ③ to ball fittings ⑦ on ROPS by firmly pushing shocks into fittings as shown. Retention clip will snap into place when shock is fully seated.

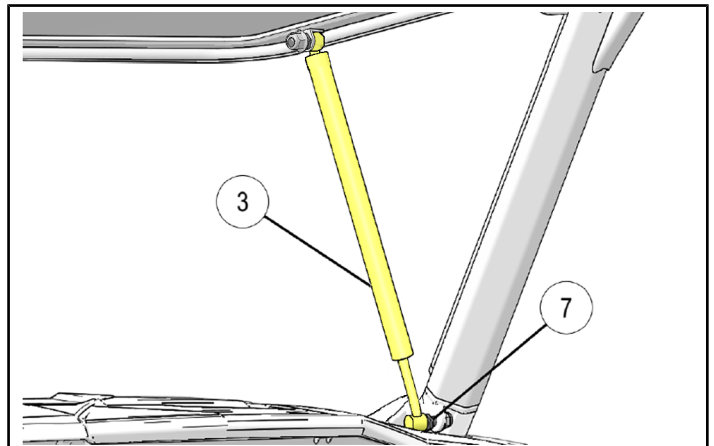

11. Using fingers, remove center storage box (D) by pressing top edge of box down, disengaging box locking tabs from main dash panel as shown. Tip box out of dash and remove.

IMPORTANT

Use only enough force to disengage locking tabs. Excessive force may damage box.

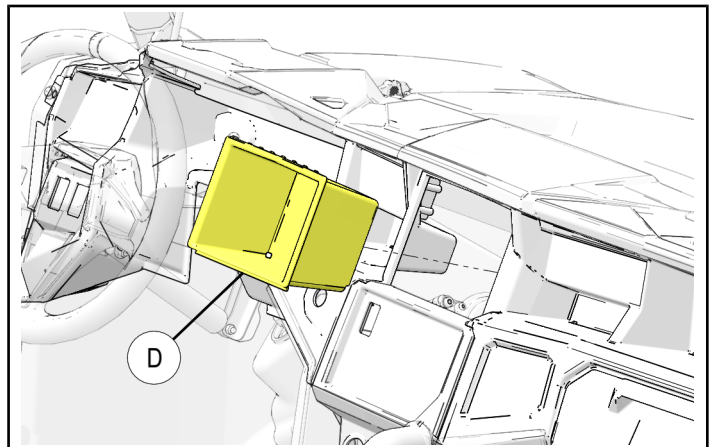

12. With windshield open, drill four 7 mm holes through upper dash panel (E) at marked locations as shown.

IMPORTANT

Control drill depth to prevent damage to underlying structure or components.

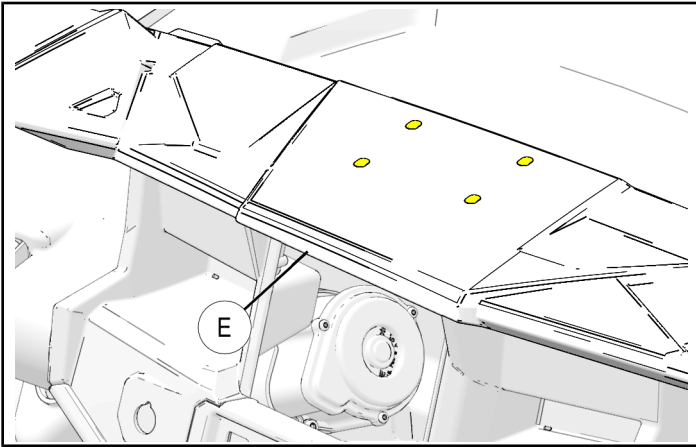

13. Install handle base (5) and backing plate (4) to upper dash panel (E) using four screws (9) as shown. Ensure proper orientation of backing plate: angled side is towards left, and welded nuts are down. Torque to specification.

TORQUE

5 ft. lbs (8 Nm)

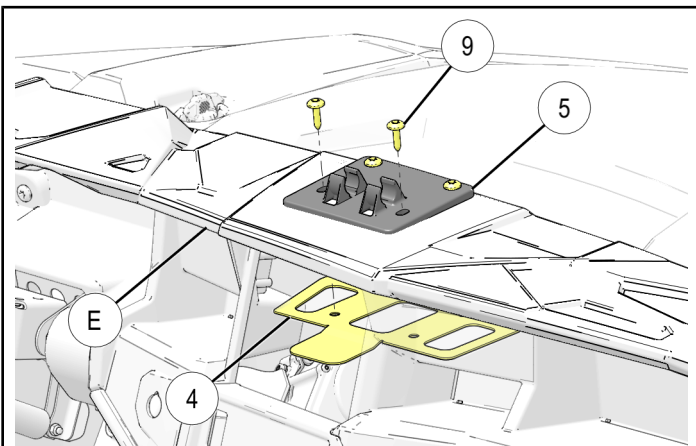

14. Close windshield and adjust as required to ensure windshield is centered and opens/closes properly.

15. Reinstall center storage box (D) by hooking lower edge of box in dash opening, then tip upper edge of box into dash until locking tabs snap into dash panel.

WARNING

Ensure safety glasses are worn to prevent eye injury!

16. OPTIONAL: To remove shock from ball fitting, insert flat bladed screwdriver into slot beneath retention clip (F) as shown. Twist slightly to disengage clip ends from ball fitting while gently pulling shock away.

IMPORTANT

Do NOT remove clip. Lift clip only enough to disengage clip ends from ball fitting.

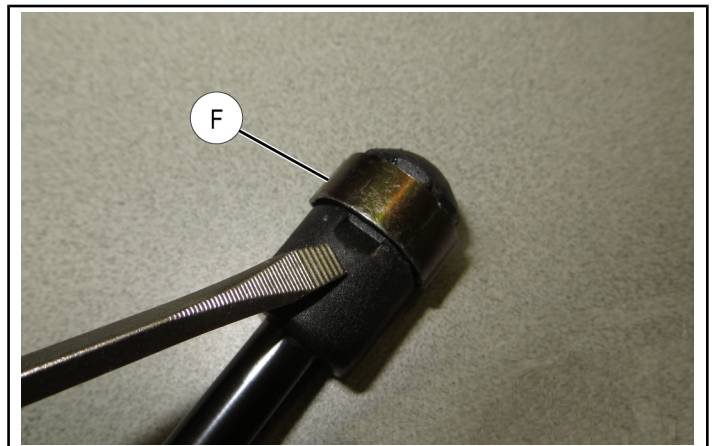

WARNING

Do NOT trailer vehicle facing rearward with windshield installed. Airflow may cause windshield to separate from vehicle, resulting in an accident and severe injury or death. Remove windshield or transport vehicle in enclosed trailer.