

SADDLEBAG PROTECTOR RAIL KIT

P/N 2880917



APPLICATION

INDIAN TOURING WITH HARD SADDLEBAGS

BEFORE YOU BEGIN

Read these instructions and check to be sure all parts and tools are accounted for. Please retain these installation instructions for future reference and parts ordering information.

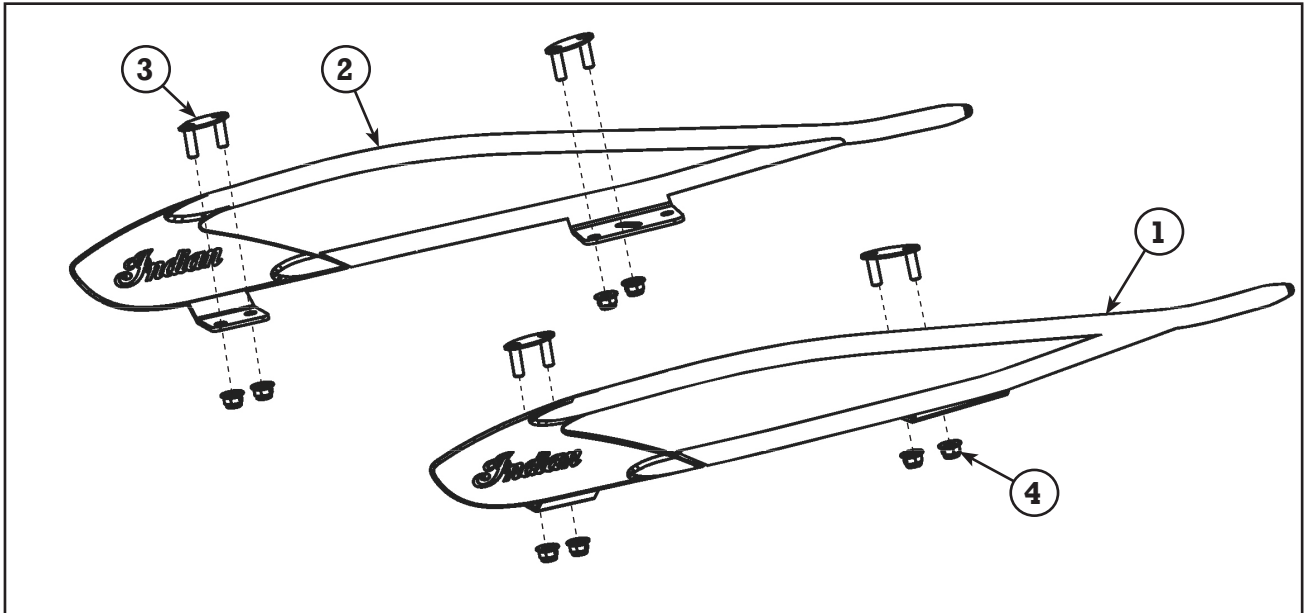

KIT CONTENTS

Ref	Qty	Part Description	Part Number
1	1	Saddlebag Rail, LH	1021233
2	1	Saddlebag Rail, RH	1021234
3	4	Stud Plate	1021235
4	8	M6 Nylon Locking Nut	7547453
	1	Instructions	9925894

TOOLS NEEDED

Hand Drill 10 mm Socket Torque Wrench 5/16" or 8 mm Drill Bit

APPROXIMATE ASSEMBLY TIME

30 min

IMPORTANT

Your Indian SADDLEBAG PROTECTOR RAIL KIT is exclusively designed for your vehicle. Please read the installation instructions thoroughly before beginning. Installation is easier if the vehicle is clean and free of debris. For your safety, and to ensure a satisfactory installation, perform all installation steps correctly in the sequence shown.

INSTALLATION INSTRUCTIONS

Vehicle Preparation Instructions

1. Protect all finished surfaces during these operations.
2. Completely empty and remove saddlebags (A) from vehicle.
3. Locate the four drill pilot hole locations located on the underside of each saddlebag bin.
4. From the outside of the saddlebag bins, center and drill four 5/16" or 8 mm holes in the pilot locations.
5. Install saddlebags back onto vehicle.

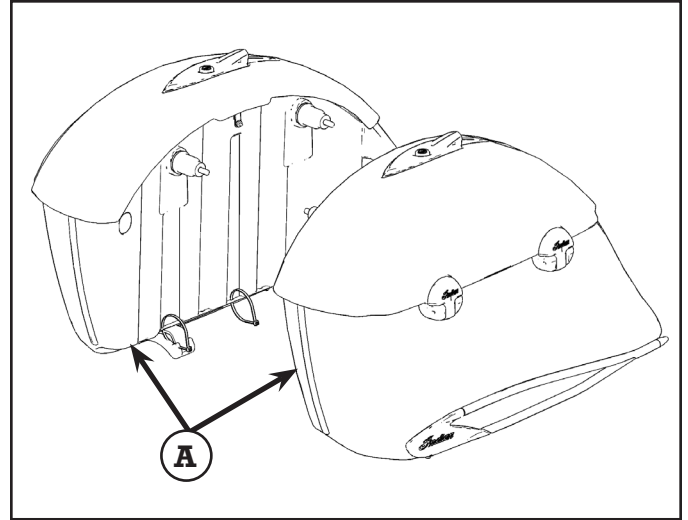

Installation

1. From the inside of one saddlebag, insert two stud plates into newly drilled holes.
2. Choose and mount saddlebag rail LH (1) so the "Indian" script placement is forward on the vehicle. Fasten into place with four nylon locking nuts (4) and torque to 30±4 in-lbs. (3.38±0.45 Nm).
3. Repeat installation steps 1-2 for RH side.

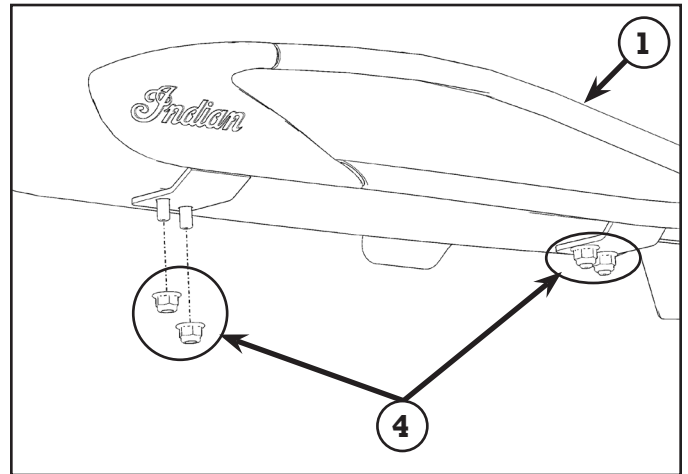

⚠ WARNING

Re-torque fasteners after 500 miles of riding.