

FRONT A-ARM GUARD KIT



P/N 2880553

APPLICATION

RANGER 900, RANGER 900 XP

BEFORE YOU BEGIN

Read these instructions twice and check to be sure all parts and tools are accounted for. Please retain these installation instructions for future reference and parts ordering information.

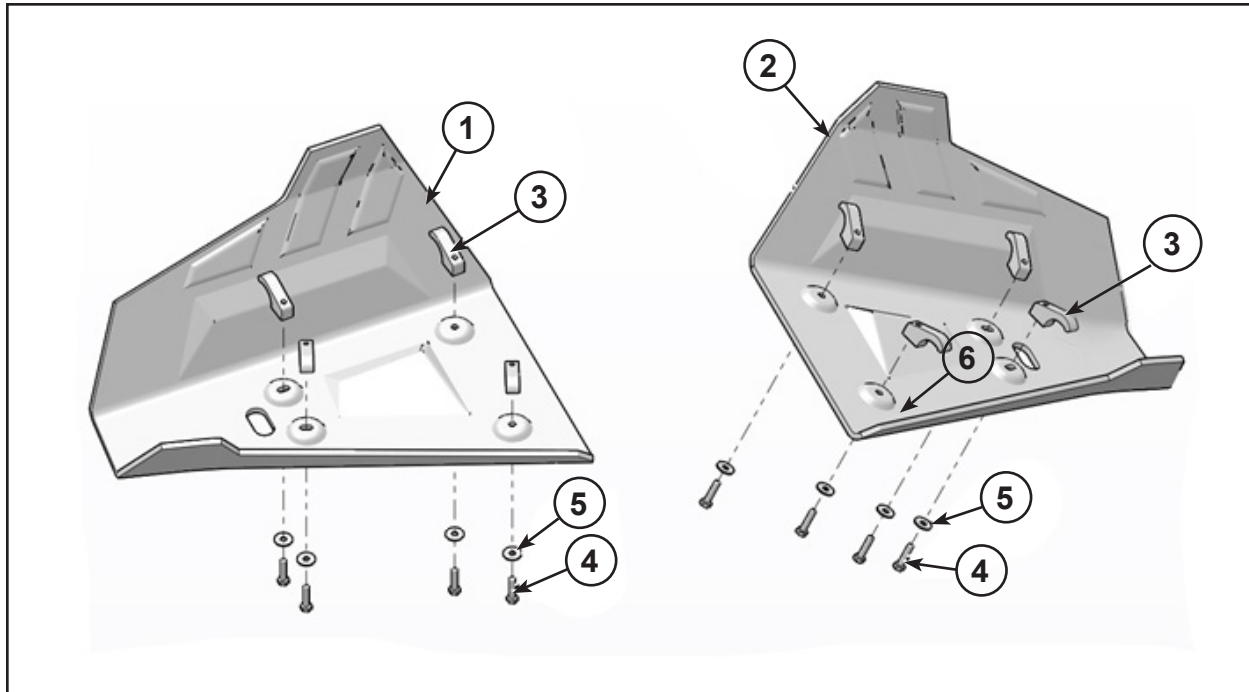

KIT CONTENTS

Ref	Qty	Part Description	Part Number
1	1	Front A-Arm Guard, LH	-
2	1	Front A-Arm Guard, RH	-
3*	8	Boot Clamp	-
4*	8	Screw-TXBH, M6X1.0X8	-
5*	8	Flat Washer, 1/4", Black	-
	1	Instructions	9925648

ITEMS MARKED (*) ARE INCLUDED IN HARDWARE KIT PN 2205736.

TOOLS NEEDED

Safety Goggles

Metric Wrench Set

Metric Socket Set

Torx Wrench

APPROXIMATE ASSEMBLY TIME

10 mins

IMPORTANT

Your Polaris FRONT A-ARM GUARD KIT is exclusively designed for your vehicle. Please read the installation instructions thoroughly before beginning. Installation is easier if the vehicle is clean and free of debris. For your safety, and to ensure a satisfactory installation, perform all installation steps correctly in the sequence shown.

INSTALLATION INSTRUCTIONS

1. Place the vehicle in “**PARK**” and turn the key to “**OFF**” position. Remove the key from the vehicle.
2. Remove the stock front shields LH (A) and RH (B) by removing the two screws (C) on each side as shown in figure.

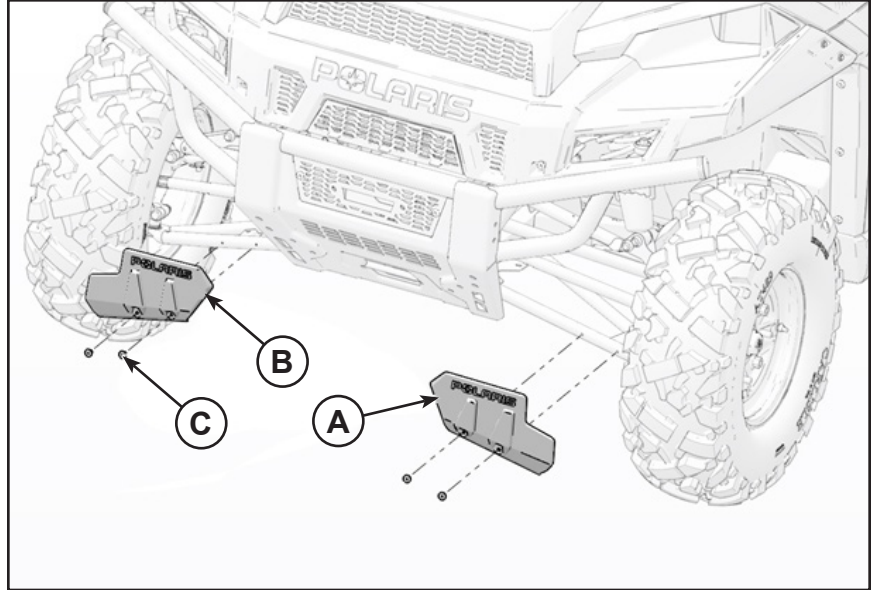

3. Loosely install the clamps (3) on the front A-arm guards, LH (1) and RH (2) using M6 screws (4) and washers (5) as shown in figure.

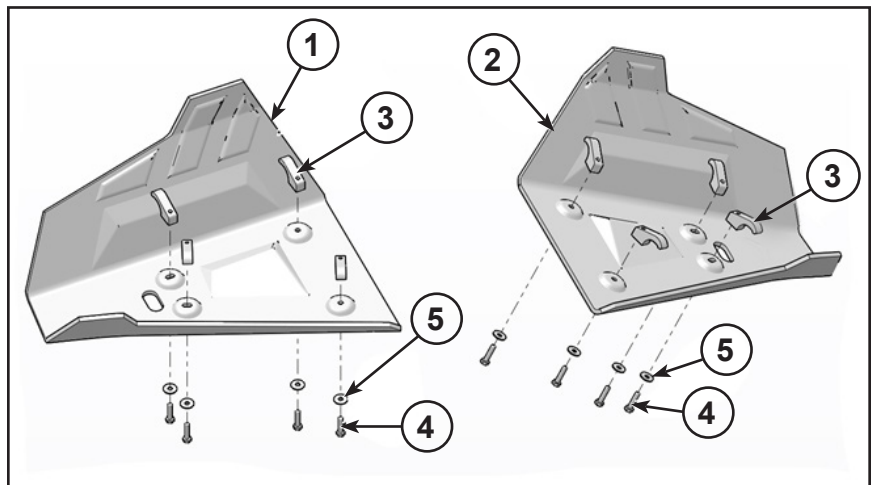

4. Adjust and install LH (1) and RH (2) A-Arm guards on the A-Arms as shown in figure.

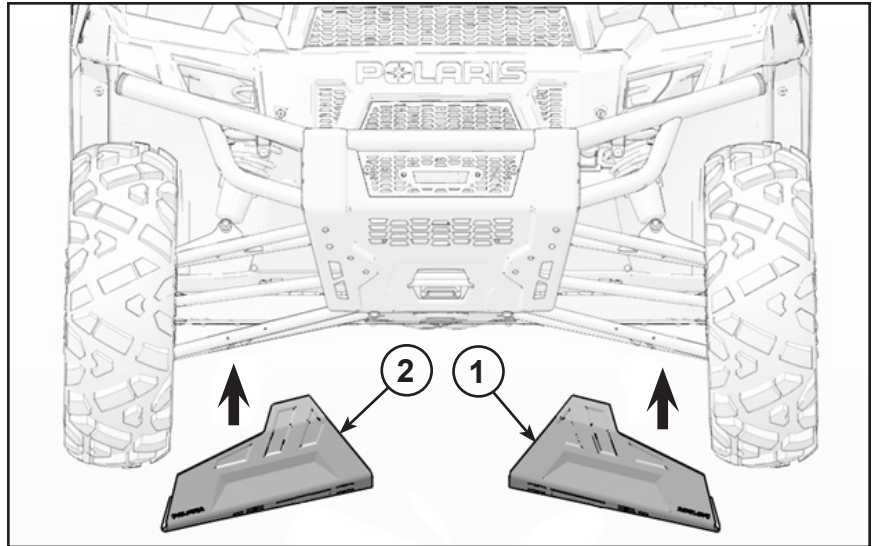

5. Tighten the M6 screws to torque 8 ft. lbs. (10.8 Nm).

