

# RGT CANVAS DOOR KIT

P/N 2879963

Application

RANGER 570 AND RANGER ETX



Before you begin, read these instructions twice and check to be sure all parts and tools are accounted for. Please retain these installation instructions for future reference and parts ordering information.

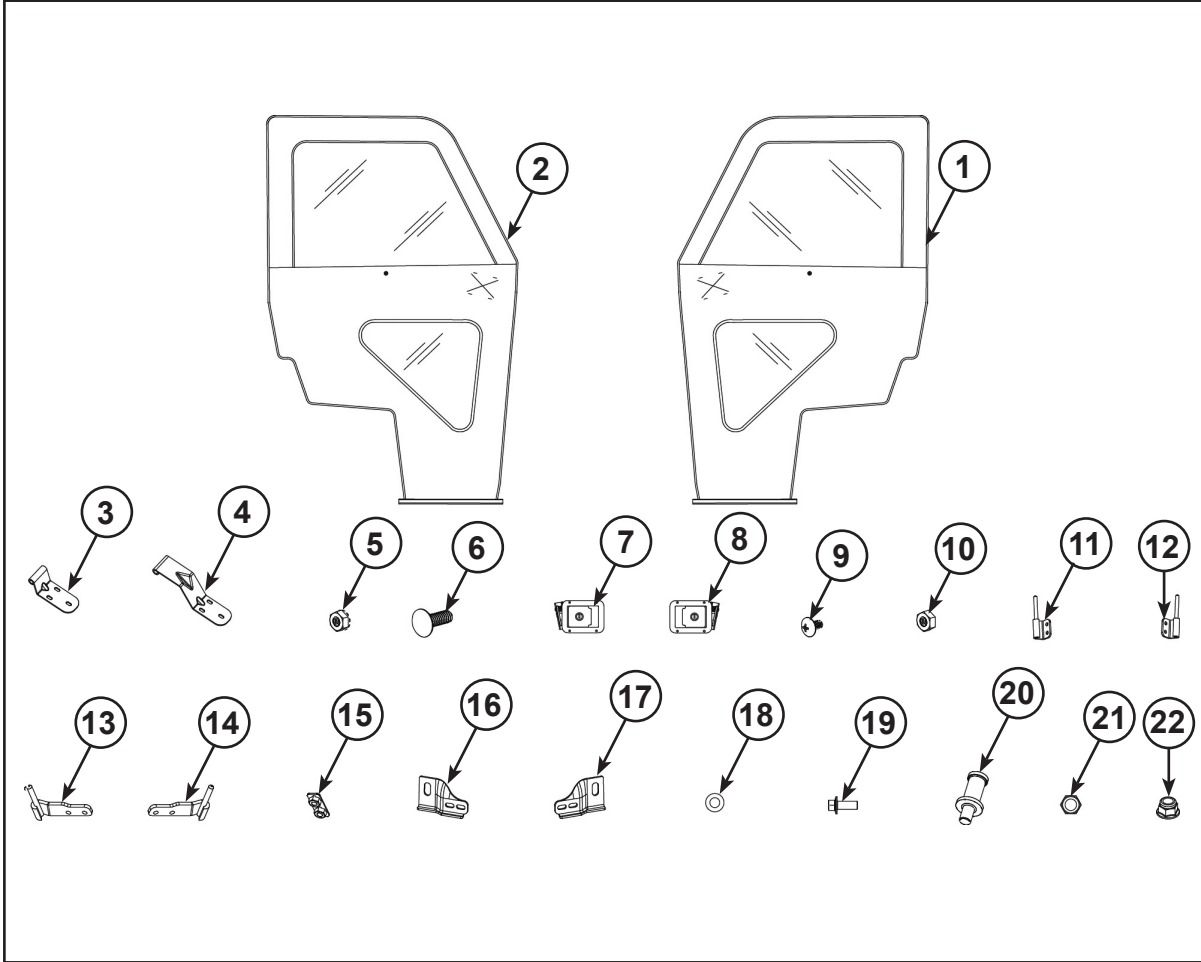

**Kit Contents:**

<u>Ref</u>	<u>Qty</u>	<u>Part Description</u>	<u>Part Number</u>
1	1	Front Canvas Frame, LH	-
2	1	Front Canvas Frame, RH	-
3*	1	Upper Hinge, LH	-
4*	1	Upper Hinge, RH	-
5*	12	Nut, 1/4-20 Kepnut	-
6*	12	Carriage Bolt 1/4-20 x 3/4"	-
7*	1	Locking Paddle Latch with Key, RT	-
8*	1	Locking Paddle Latch with Key, LT	-
9*	8	Screw, #10-32 X 3/8", Truss Head CR	-
10*	8	Nut, #10-32 Hex Lock	-
11*	1	Upper Hinge Bracket Weldment, LH	1019785
12*	1	Upper Hinge Bracket Weldment, RH	1019786

<u>Ref</u>	<u>Qty</u>	<u>Part Description</u>	<u>Part Number</u>
13*	1	Hinge Bracket Weldment, ROPS, FRL	1020368
14*	1	Hinge Bracket Weldment, ROPS, FRR	1020369
15*	2	Hinge Plate	5256140
16*	1	Door Bracket, Striker Mount, LH	5258793
17*	1	Door Bracket, Striker Mount, RH	5258794
18*	4	Flat Washer-10.25X19X2	5439712
19*	12	M8 Screw-1.25X20 HXFL	7517838
20*	2	Striker Pin	7519358
21*	2	Nut, M12-1.75 Hex 8 Z Nyloc	7540000
22*	4	Nut, Hex-M8-1.25 8 ZB3 Nyloc	7547454
	1	Instructions	9925423

Items marked (\*) are included in Hardware Kit PN 2205782.

**Tools Required:**

Metric Socket Set

Metric Wrench Set

Torx Wrench

**APPROXIMATE ASSEMBLY TIME:** 30 minutes

**IMPORTANT:** Your Polaris RGT CANVAS DOORS KIT is exclusively designed for your vehicle. Please read the installation instructions thoroughly before beginning. Installation is easier if the vehicle is clean and free of debris. For your safety and to ensure a satisfactory installation, perform all installation steps correctly and in the sequence shown.

**INSTALLATION INSTRUCTIONS:**

1. Place the vehicle in "PARK". Turn the key to "OFF" position and remove from the vehicle.
2. Remove the driver's side net starting by removing the four M6 screws at two places. Figure 1.

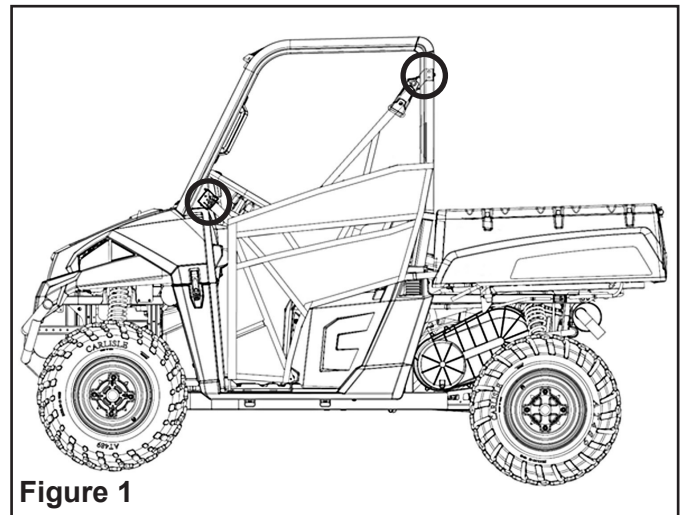

Figure 1

3. Install the upper hinge weldment (PN 1019785) and hinge plate (PN 5256140) on the ROPS bracket using two M8 screws (PN 7517838). Figure 2.

**NOTE:** Slide the hinge plate in the direction of arrow.

**IMPORTANT:** Do not torque the bolts.

4. Put the cargo box in unload (slant) condition.

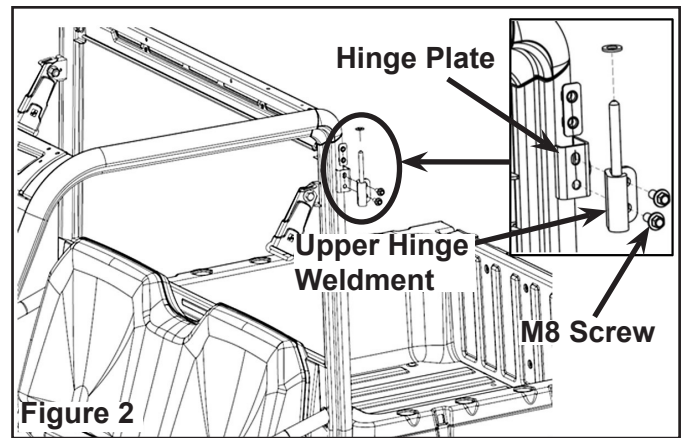

5. Install the hinge bracket (PN 1020368) on the ROPS using two M8 screws (PN 7517838) Figure 3.

**IMPORTANT:** Do not torque the bolts.

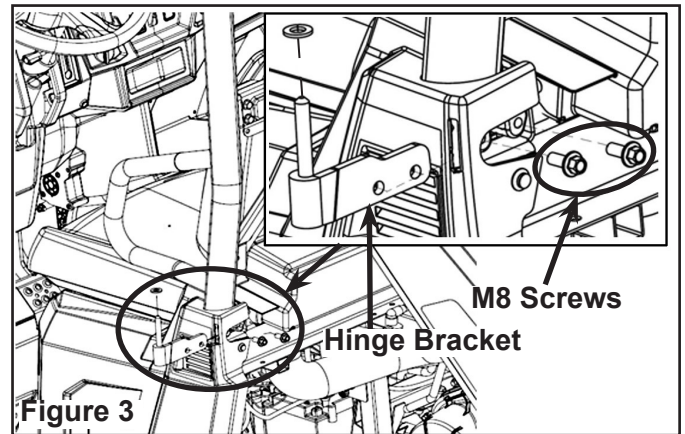

6. Install the door bracket (PN 5258793) on the weld-cab frame using two M8 screws (PN 7517838). Figure 4.

**IMPORTANT:** Do not torque the bolts.

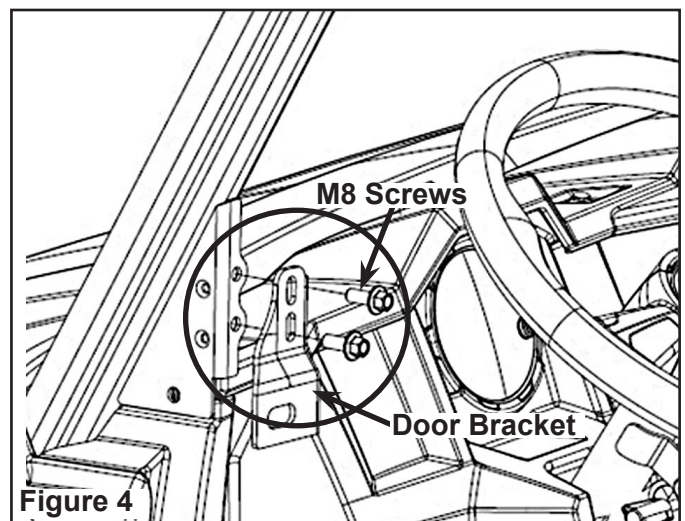

7. Install the striker pin (PN 7519358) on the weld-cab frame using one M12 nut (PN 7540000). Figure 5.

**IMPORTANT:** Do not torque the bolts.

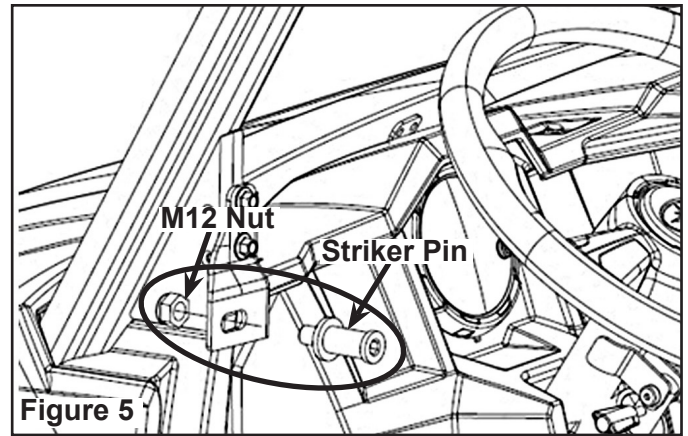

8. Install hinges and door latch on door. Do not tighten fasteners at this time. Figure 6.

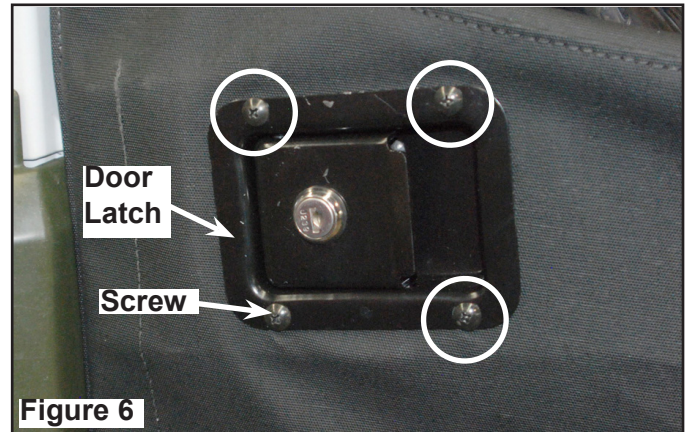

9. Adjust and mount the door on to hinges. Figure 7.
10. Adjust the door latch with the striker pin and ensure door is locking properly.
11. Torque all the M8 screws to 16 ft-lbs.(21.7 Nm) and M12 nut to 54 ft-lbs.(73.2 Nm).
12. Repeat Step 2 to Step 11 to install the passenger side door.

