

Installation and Cabling Diagram:

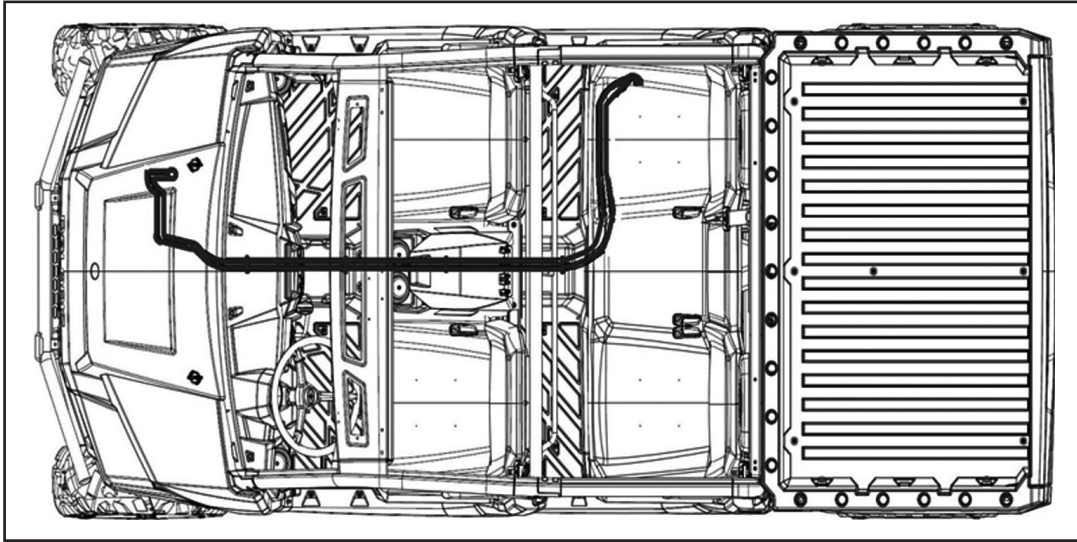

INSTALLATION INSTRUCTIONS:

1. Place the vehicle in "PARK". Turn the key to the "OFF" position and remove from vehicle. Remove the driver seat. Disconnect the black negative and red positive battery cables from the battery. Figure 1.

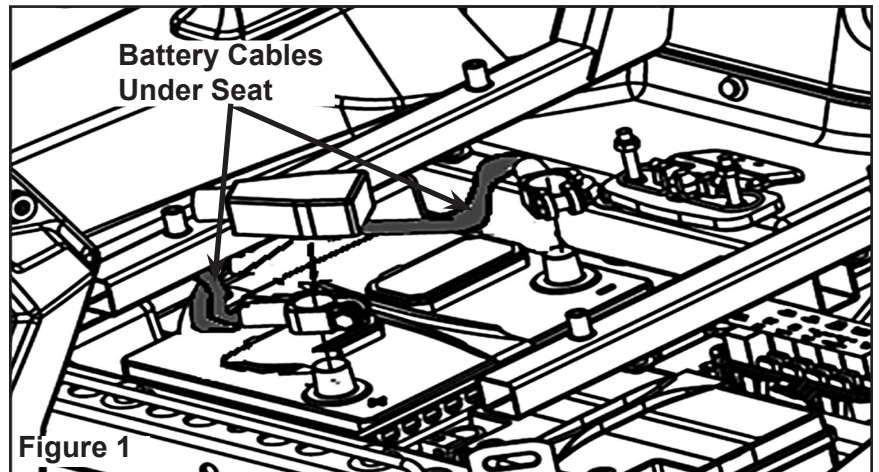

2. Remove both the seat base and the storage boxes by pulling in the direction of arrow. Figure 2.

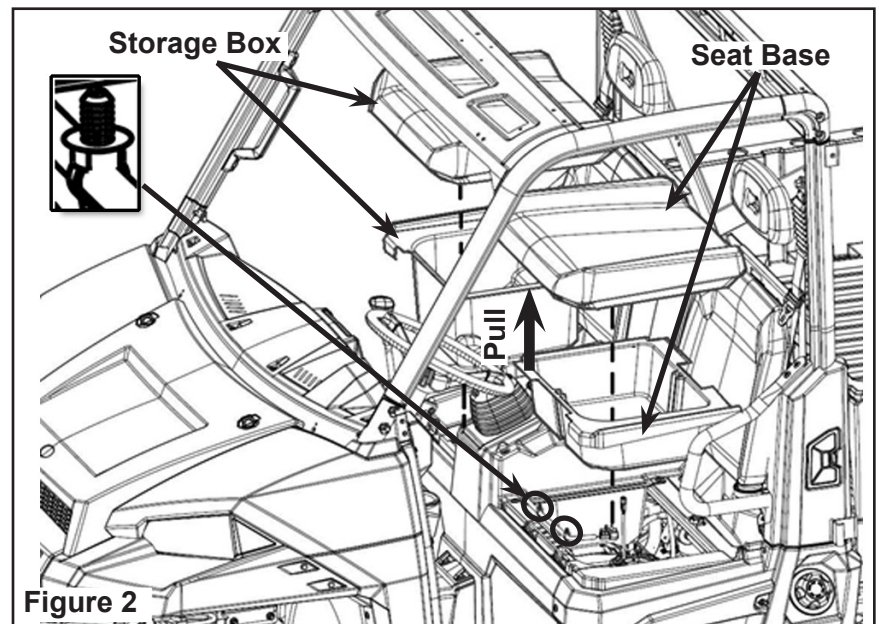

3. Remove the hood from the vehicle by twisting the two knobs and pulling up. Figure 3.

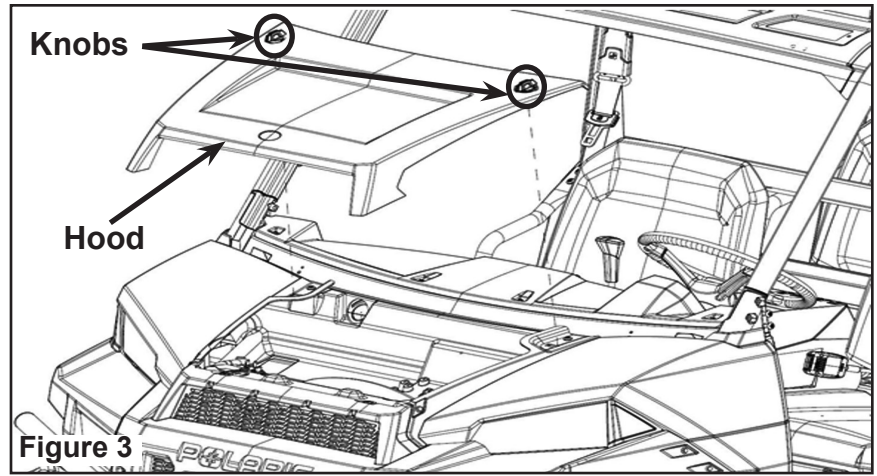

4. Remove the drive cover shaft by removing four tuflok rivets (PN 7661855). Figure 4.

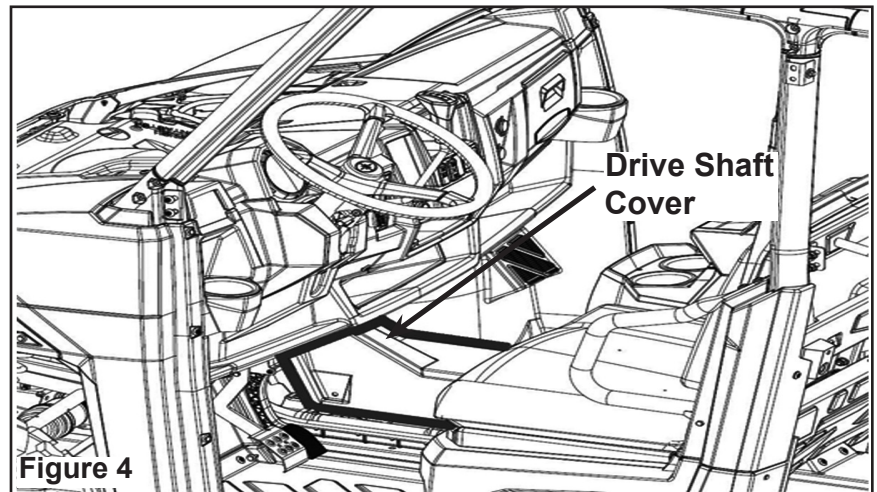

5. Connect one end of wire harness to the third post bus bar terminal (include the red cap). Figure 5.

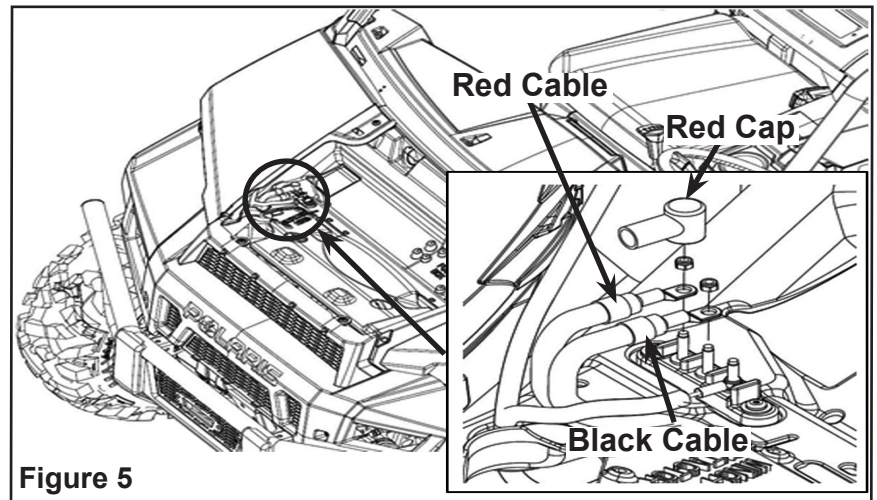

6. Route the wires alongside the main harness under the hood. Figure 6.
7. Attach quick retainers of harness to the bulkhead bracket. Figure 6.

IMPORTANT: Ensure the other end of the wire is not connected to solenoid or ground terminal at this point.

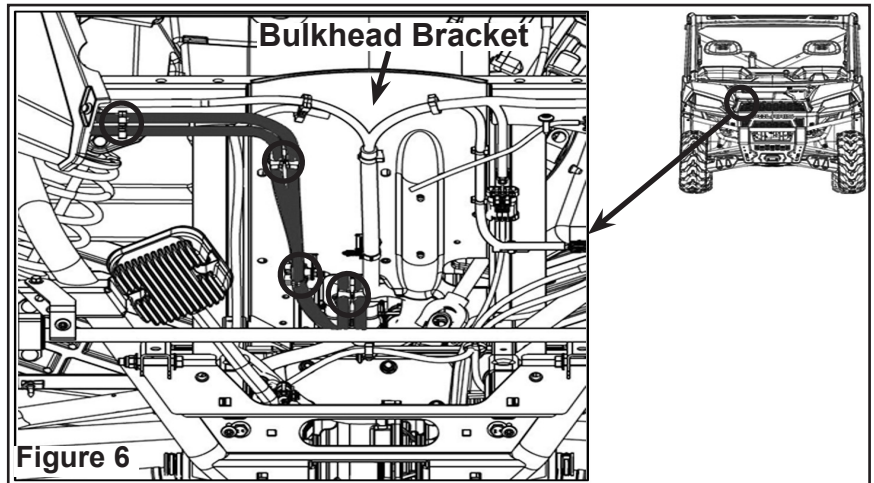

8. Route the wires above the coolant lines and slide under the seat from where the drive shaft cover is removed. Figure 7.

NOTE: The cables underneath upper floor follow the cooling lines. Figure 7.

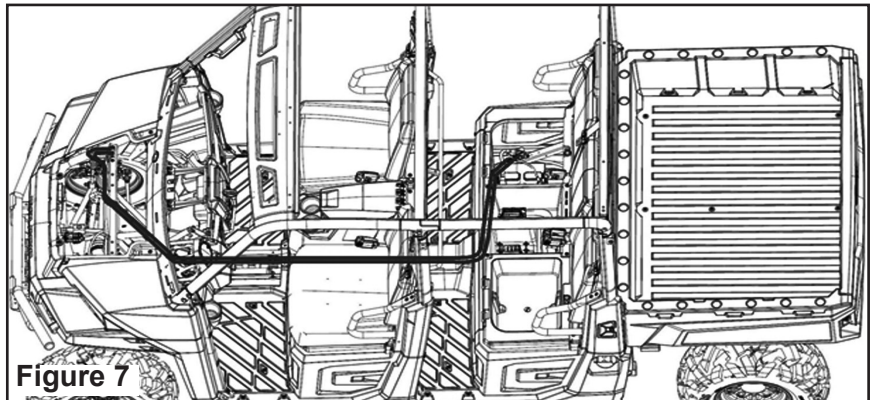

9. Attach the red cable to the battery side of starter solenoid and black cable to ground post. Figure 8.
10. Connect the negative and positive cables to the battery which is disconnected in Step 1.
11. Install the rear seat, storage box, hood and drive shaft cover which were removed in Step 2, Step 3 and Step 4.

