

SPARE TIRE MOUNT KIT

P/N 2879464



POLARIS®

Application

MY 2014 RZR XP

Before you begin, read these instructions twice and check to be sure all parts and tools are accounted for. Please retain these installation instructions for future reference and parts ordering information.

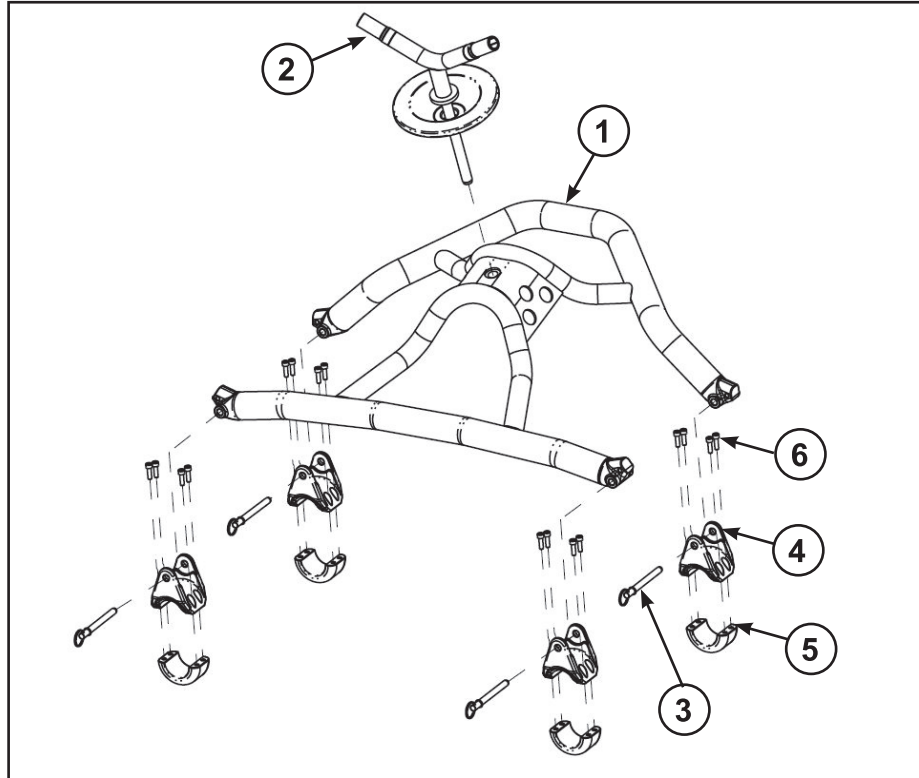

This Kit Includes:

<u>Ref</u>	<u>Qty</u>	<u>Part Description</u>	<u>Part Number</u>
1.....	1	Weld-Mount	1019818
2.....	1	Weld-Handle	1019949
3.....	4	Pin - Hitch, Tab	7662167
4*	4	Clamp-Mach, Main	5450730
5*	4	Clamp-Mach, Cap	5450731
6*	16	Bolt M6 x1.0 x 20	7517305
	1	Instructions	9924466

Item marked (*) are included in Kit PN 2205117

Tools Required:

Safety Glasses

5 mm Allen Socket

Torque Wrench

APPROXIMATE ASSEMBLY TIME (R&R): 10-15 minutes

IMPORTANT: Your Polaris Spare Tire Mount for the RZR XP 1000 is exclusively designed for your vehicle. For your safety, and to ensure a satisfactory installation, perform all installation steps correctly in the sequence as shown on the attached instructions. Please wear safety glasses while performing the steps in the following instructions.

INSTALLATION INSTRUCTIONS

1. Install clamps (PN 5450730 and PN 5450731) on ROPS frame loosely with bolts (PN 7517305) at the four locations as shown in Figure 1.

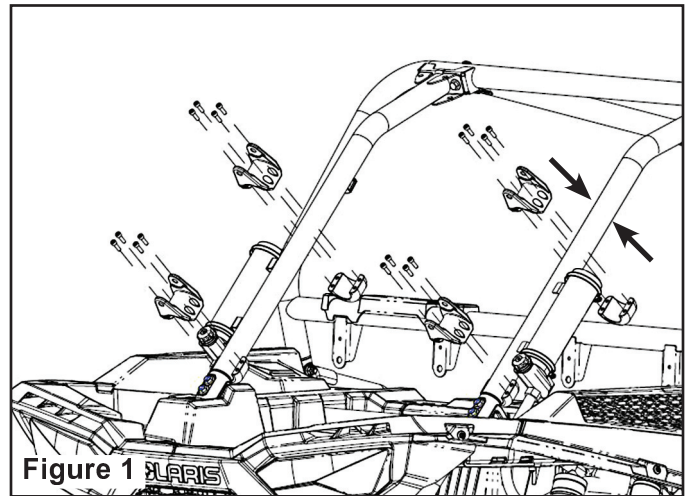

2. Align the clamps to the tire mount (PN 1019818) to ensure a proper fit. Figure 2.

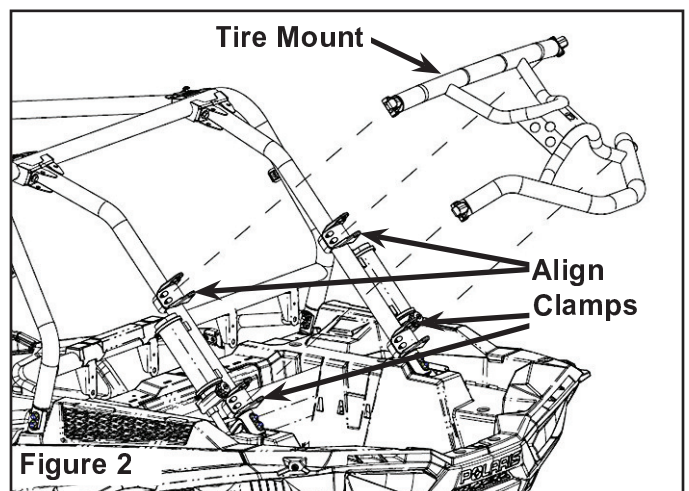

3. Install the pins (PN 7662167) by inserting through the holes in the clamps and the tire mount. You may need to adjust the clamps to accomplish this. Figure 3.

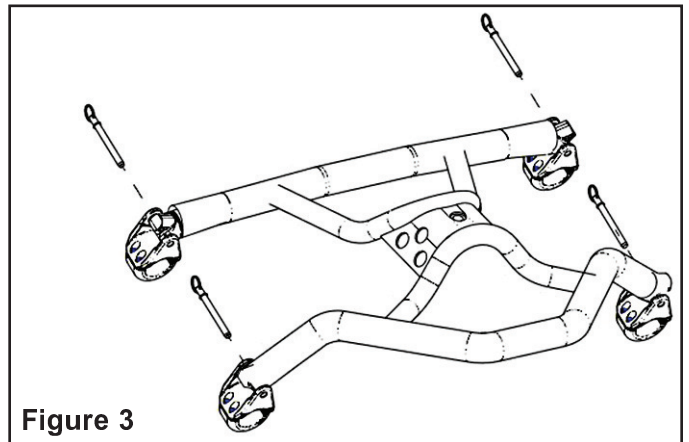

4. When the tire mount is aligned properly, tighten the bolts on each clamps. Torque to 8 ft. lbs. (10.8 Nm). Figure 3.

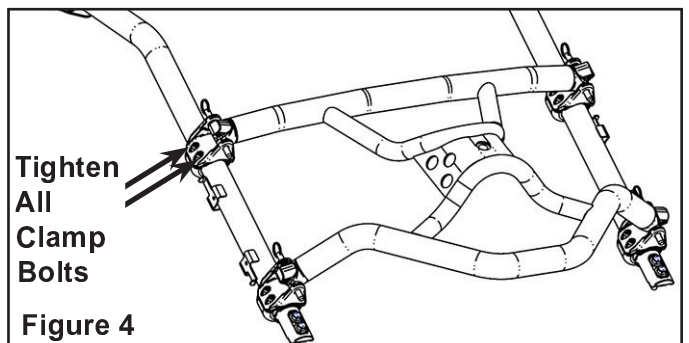

5. Install weld handle and tighten it by twisting in the direction of arrow. Figure 3.

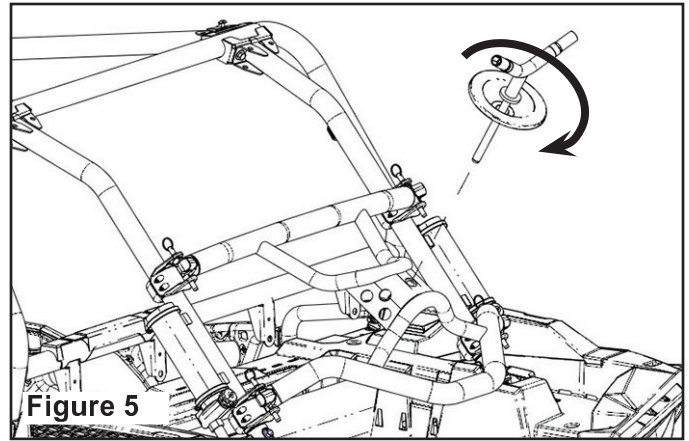

6. To prevent damage to the rim, make sure the tire is mounted on the vehicle as shown in Figure 6. **NOTE:** If tire has a rim cap attached, remove and save for future use.

